



**AgEcon** SEARCH  
RESEARCH IN AGRICULTURAL & APPLIED ECONOMICS

*The World's Largest Open Access Agricultural & Applied Economics Digital Library*

**This document is discoverable and free to researchers across the globe due to the work of AgEcon Search.**

**Help ensure our sustainability.**

Give to AgEcon Search

AgEcon Search

<http://ageconsearch.umn.edu>

[aesearch@umn.edu](mailto:aesearch@umn.edu)

*Papers downloaded from **AgEcon Search** may be used for non-commercial purposes and personal study only. No other use, including posting to another Internet site, is permitted without permission from the copyright owner (not AgEcon Search), or as allowed under the provisions of Fair Use, U.S. Copyright Act, Title 17 U.S.C.*

# **SMALL-SCALE IRRIGATION AND WATER MANAGEMENT TECHNOLOGIES FOR AFRICAN AGRICULTURAL TRANSFORMATION**

Adebayo Oke, Kalifa Traore, Aïssata Delphine Nati-Bama,  
Henry Igbadun, Bashir Ahmed, Fentaw Ahmed and Sander Zwart

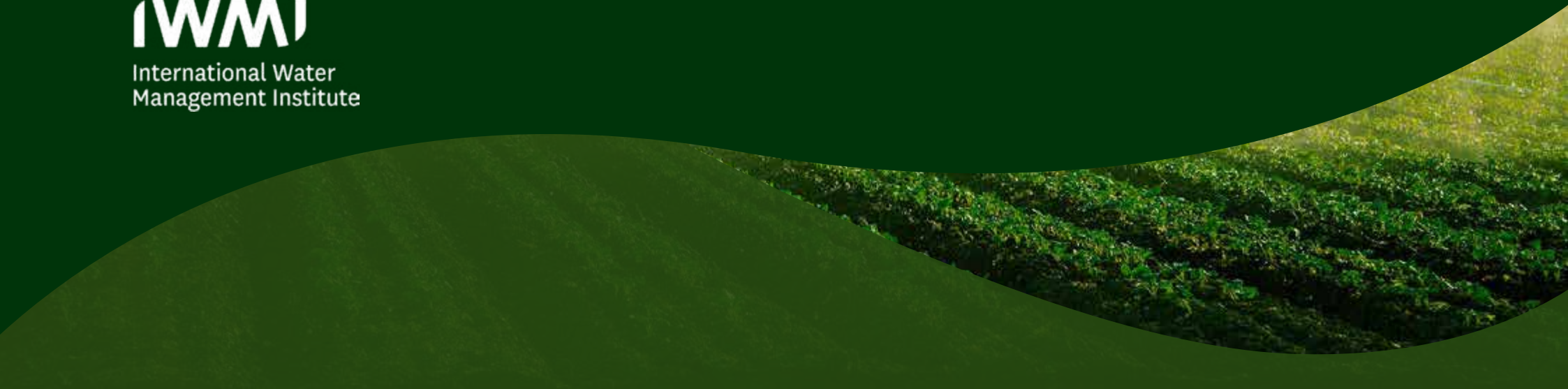



# **SMALL-SCALE IRRIGATION AND WATER MANAGEMENT TECHNOLOGIES FOR AFRICAN AGRICULTURAL TRANSFORMATION**

Adebayo Oke, Kalifa Traore, Aïssata Delphine Nati-Bama, Henry Igbadun,  
Bashir Ahmed, Fentaw Ahmed and Sander Zwart



## THE AUTHORS

**Dr. Adebayo OKE (Nigeria)** is Senior Research Fellow Irrigation and Water Resources Engineering at the Institute of Agricultural Research and Training, Obafemi Awolowo University in Ibadan, Oyo State Nigeria.

**Dr. Kalifa TRAORE (Mali)** is Scientific Director at the Institute of Rural Economy (IER) in Bamako, Mali.

**Dr. Aïssata Delphine NATI-BAMA (Burkina Faso)** is Senior Researcher Irrigation at the Institute of Environment and Agricultural Research (INERA) in Ouagadougou, Burkina Faso.

**Dr. Henry IGBADUN (Nigeria)** is Professor of Irrigation, Soil and Water Conservation Engineering at the Institute of Agricultural Research, Ahmadu Bello University in Zaria, Kaduna State, Nigeria.

**Dr. Bashir AHMED (Sudan)** is Senior Researcher Irrigation Water Management and Remote Sensing at the Agricultural Research Corporation in Wad Madani, Sudan.

**Dr. Fentaw AHMED (Ethiopia)** is retired Senior Researcher Agricultural Water Management at the Ethiopian Institute for Agricultural Research (EIAR) in Addis Ababa, Ethiopia.

**Dr. Sander ZWART (Netherlands)** is Senior Researcher Water & Climate Change Adaptation at the International Water Management Institute in Accra, Ghana.

## CITATION

Oke, A.; Traore, K.; Nati-Bama, A. D.; Igbadun, H.; Ahmed, B.; Ahmed, F.; Zwart, S. 2022. *Small-scale irrigation and water management technologies for African agricultural transformation*. Colombo, Sri Lanka: International Water Management Institute (IWMI). 166p.

doi:<https://doi.org/10.5337/2022.212>

/ small-scale irrigation / water management / technology / agricultural transformation / smallholders / farmer-led irrigation / land resources / water resources / water supply / pumping / shallow water / groundwater / tube wells / runoff water / water harvesting / ponds / embankments / dams / conveyance structures / pipes / irrigation methods / surface irrigation / basin irrigation / border irrigation / furrow irrigation / sprinkler irrigation / drip irrigation / irrigation systems / irrigation scheduling / wetting front / soil water content / sensors / contour cultivation / tillage / land levelling / soil moisture / moisture conservation / water conservation / techniques / crop production / water requirements / water use efficiency / irrigation equipment / maintenance / irrigation efficiency / solar energy / cost analysis / investment / business models / capacity development / training materials / learning activities / Africa /

ISBN: 978-92-9090-942-2

**Disclaimer:** This publication has been prepared with care by the authors. Responsibility for editing, proofreading and design/layout of the document, and for any remaining errors and opinions expressed lies with the authors and not the institutions involved.

Copyright © 2022, by IWMI. All rights reserved. IWMI encourages the use of its material provided that the organization is acknowledged and kept informed in all such instances. The boundaries and names shown and the designations used on maps do not imply official endorsement or acceptance by IWMI.

Please send inquiries and comments to [IWMI-Publications@cgiar.org](mailto:IWMI-Publications@cgiar.org)

For access to all IWMI publications, visit: [www.iwmi.org/publications/](http://www.iwmi.org/publications/)

**Copy editor:** Alex OHEMENG

**Translator English-French:** Cheikh Ahmed Tidjane GAMBONE

**Illustrator:** Felix KYERE-AMPONSAH

**Graphic designer:** Abigail Ruth WENCHIE

## PROJECT

This field guide was developed for the Technologies for African Agricultural Transformation – Water Enabler Compact (TAAT–WEC) project (2018–2022) funded by the African Development Bank (AfDB) through Grant No. 2100155036067.



# Contents

|                           |          |
|---------------------------|----------|
| <b>Introduction .....</b> | <b>1</b> |
| Training Approach.....    | 2        |
| Training Modules.....     | 4        |

## **MODULE 1**

### **Assessing Land and Water Resources for Farmer-Led Irrigation**

|   |           |
|---|-----------|
| <b>Development.....</b>   | <b>11</b> |
| 1.1 Smallholder Farmer-Led Irrigation Practice .....                | 13        |
| 1.2 Highlights of Smallholder Farmer-Led Irrigation Practices ..... | 13        |
| 1.2.1 Requirement for Small-Scale Farmer-Led Irrigation .....       | 14        |
| 1.2.2 Assessment of Land, Water and Other Required Resources .....  | 15        |
| 1.3 Major Considerations for Irrigation Planning .....              | 17        |
| 1.3.1 Weather Characteristic .....                                  | 17        |
| 1.3.2 Crop Water Requirement .....                                  | 17        |
| 1.3.3 Soil Type.....  | 19        |
| 1.3.4 Topography.....   | 20        |
| 1.3.5 Water Source.....   | 20        |
| 1.3.6 Business Considerations .....                                 | 20        |

## **MODULE 2**

### **Water Lifting / Pumping Devices.....** | | | |---|----| | 2.1 Water Pumping from Rivers and Other Open Water Sources..... | 25 | | 2.2 Potential Benefits ..... | 25 | | 2.3 Investment Costs and Profitability ..... | 26 | | 2.4 Applications Domains ..... | 26 | | 2.5 Pump Selection Consideration..... | 29 | | 2.5.1 Irrigation Methods and Pump Capacity..... | 31 | | | | |--|----| | 2.5.2 Energy Concerns ..... | 33 | | 2.5.3 Design and Installation Requirements ..... | 33 | | 2.6 Basic Steps of Pump Installation and Operation ..... | 33 | | 2.7 Pump and Irrigation System Troubleshooting..... | 34 | **MODULE 3** **Shallow Groundwater Tube Well Development .....** | | | |---|----| | 3.1 Tube Well for Shallow Groundwater in Flood Plains ..... | 39 | | 3.2 Potential Benefits ..... | 40 | | 3.3 Applications Domains ..... | 40 | | 3.4 Investment Consideration for Tube Well Acquisition ..... | 42 | | 3.5 Drilling Methods..... | 43 | | 3.5.1 Hand Auger ..... | 43 | | 3.5.2 Jetting ..... | 44 | | 3.6 Tools and Equipment Required for Drilling Tube Well Using Jetting Method..... | 44 | | 3.7 Steps in Tube Well-Digging Using Jetting Technique..... | 45 | | 3.8 Operation and Maintenance..... | 49 | | 3.8.1 Tube Well Maintenance ..... | 49 | | 3.8.2 Pump Maintenance ..... | 49 | **MODULE 4** **Runoff Water Harvesting: Farm Pond and Embankment Dam** **Development.....** | | | |--|----| | 4.1 Runoff Water Harvesting..... | 53 | | 4.2 Potential Benefits ..... | 53 | | 4.3 Application Domains ..... | 53 | | 4.3.1 Preliminary Considerations ..... | 54 | | 4.4 Investment Cost Considerations..... | 55 | | 4.5 Steps to The Construction..... | 55 | | 4.5.1 Construction of Farm Pond ..... | 55 | | 4.5.2 Embankment Dam/Sand Bag Construction ..... | 58 | v



|                                    |    |
|------------------------------------|----|
| 4.6 Operation and Maintenance..... | 61 |
|------------------------------------|----|

## MODULE 5

|   |           |
|---|-----------|
| <b>Closed Pipe Conveyance System .....</b>                          | <b>63</b> |
| 5.1 Closed Pipe Conveyance Systems for Smallholder Irrigation ..... | 65        |
| 5.2 Potential Benefits.....   | 66        |
| 5.3 Application Domains .....                                       | 66        |
| 5.4 Investment Costs Considerations .....                           | 66        |
| 5.5 Design and Installation Guide .....                             | 67        |
| 5.5.1 Installation Considerations.....                              | 67        |
| 5.5.2 Considerations for Layouts of HDPE/PVC Conveyance .....       | 70        |
| 5.5.3 Example of Field Conveyance Set-Up .....                      | 71        |
| 5.6 Operation and Maintenance.....                                  | 72        |

## MODULE 6

|   |           |
|---|-----------|
| <b>Surface Irrigation: Basin, Border Strip and Furrow Systems .....</b> | <b>73</b> |
| 6.1 Surface Irrigation .....  | 75        |
| 6.2 Basin Irrigation.....   | 75        |
| 6.2.1 Application Domains.....  | 75        |
| 6.2.2 Crops.....  | 75        |
| 6.2.3 Topography.....   | 76        |
| 6.2.4 Soils .....   | 76        |
| 6.2.5 Stream Size .....   | 76        |
| 6.3 Investment Costs and Feasibility .....                              | 76        |
| 6.4 Design and Installation .....                                       | 76        |
| 6.4.1 Basin Design .....  | 76        |
| 6.4.2 Check Basin.....  | 78        |
| 6.5 Border Strips .....   | 79        |
| 6.6 Furrow .....  | 81        |
| 6.6.1 Efficient Water Application Pattern in Furrow .....               | 82        |
| 6.6.2 Planting Considerations in Furrow Irrigation .....                | 83        |
| 6.7 Operation and Maintenance.....                                      | 83        |

## MODULE 7

|  |           |
|--|-----------|
| <b>Sprinkler Irrigation Systems .....</b>                | <b>85</b> |
| 7.1 Sprinkler Irrigation Technology .....                | 87        |
| 7.2 Potential Benefits .....                             | 88        |
| 7.3 Application Domains .....                            | 88        |
| 7.4 Investment and Costs Considerations .....            | 88        |
| 7.5 Design and Installation .....                        | 88        |
| 7.5.1 Irrigated Area.....                                | 89        |
| 7.5.2 Description of Sprinkler System Components .....   | 89        |
| 7.5.3 What to Look for in Your Sprinkler.....            | 91        |
| 7.5.4 Water Conveyance System.....                       | 91        |
| 7.5.5 Layout Methods .....                               | 91        |
| 7.5.6 Spacing Arrangements for Selected Sprinklers ..... | 92        |
| 7.6 Installation Guide.....                              | 93        |
| 7.7 Operation and Maintenance.....                       | 94        |

## MODULE 8

|  |           |
|--|-----------|
| <b>Drip Irrigation Systems .....</b>                 | <b>97</b> |
| 8.1 Drip Irrigation Practices.....                   | 99        |
| 8.2 Potential Benefits.....                          | 99        |
| 8.3 Application Domain .....                         | 99        |
| 8.4 Investment Requirement .....                     | 100       |
| 8.5 Design and Installations.....                    | 100       |
| 8.5.1 Materials and Drip System Components .....     | 100       |
| 8.5.2 Drip Irrigation Installation .....             | 102       |
| 8.5.3 Installation of Drip System Beyond 1Acre ..... | 104       |
| 8.6 Operation and Maintenance.....                   | 104       |

## MODULE 9

|  |            |
|--|------------|
| <b>Irrigation Scheduling with FullStop™ Wetting Front Detectors.....</b> | <b>107</b> |
| 9.1 Introduction .....   | 109        |
| 9.2 Potential Benefits .....   | 109        |

|  |            |  |            |
|--|------------|--|------------|
| 9.3 Application Domains .....  | 110        | 11.6 Maintenance of The Permanent Contour Ridge .....                  | 137        |
| 9.4 Investment Costs .....   | 110        |  |            |
| 9.5 Assembling the WFD .....   | 110        | <b>MODULE 12</b>   |            |
| 9.6 Depth of Placement of WFD .....                                  | 113        | <b>Laser Levelling – Engineered Surface for Irrigation .....</b>       | <b>139</b> |
| 9.7 Installation of WFD .....  | 113        | 12.1 Laser Levelling for Improving Surface Irrigation Efficiency ..... | 141        |
| 9.8 Reading Soil Water Status .....                                  | 116        | 12.2 Benefits of Land Levelling .....                                  | 141        |
| 9.9 Monitoring Nutrients and Salt .....                              | 117        | 12.3 Basic Features of A Laser-Controlled Land Levelling System .....  | 143        |
| 9.10 Maintenance of WFDs .....                                       | 117        | 12.3.1 Laser Transmitter .....   | 143        |
| 9.11 Link to Installation Videos .....                               | 117        | 12.3.2 Laser Receiver .....  | 143        |
| 9.12 Limitations .....   | 117        | 12.3.3 Control Box .....   | 144        |
|  |            | 12.3.4 Hydraulic Control System .....                                  | 144        |
| <b>MODULE 10</b>   |            | 12.3.5 Laser-Level Land Requirements .....                             | 145        |
| <b>Irrigation Scheduling with Chameleon™ Soil Water Sensors.....</b> | <b>119</b> | 12.3.6 Ploughing The Field.....  | 145        |
| 10.1 Chameleon Soil Water Sensor .....                               | 121        | 12.3.7 Topographic Survey .....  | 145        |
| 10.2 Potential Benefits .....  | 122        | 12.3.8 Other Equipment Required .....                                  | 146        |
| 10.3 Application Domains .....                                       | 122        | 12.4 Application Domain and Limitation .....                           | 146        |
| 10.4 Investment Costs .....  | 122        | 12.5 Steps Required for Levelling The Field.....                       | 146        |
| 10.5 Depth of Placement of Sensors .....                             | 123        | 12.5.1 Estimating Time Required for Cutting and Filling .....          | 147        |
| 10.6 Installation of Chameleon.....                                  | 123        | 12.5.2 Troubleshooting .....   | 148        |
| 10.7 Reading Soil Water Status.....                                  | 124        |  |            |
| 10.8 Operation and Maintenance .....                                 | 127        | <b>MODULE 13</b>   |            |
| 10.9 Link to Video on How The Chameleon Works .....                  | 127        | <b>Soil Moisture Conservation Techniques .....</b>                     | <b>149</b> |
| 10.10 Link to Videos on Repair and Maintenance .....                 | 127        | 13.1 In-Situ Water Harvesting for Soil Moisture Conservation.....      | 151        |
| 10.11 Link to Videos of Success Stories .....                        | 127        | 13.2 Soil Moisture Conservation Techniques .....                       | 151        |
|  |            | 13.3 Potential Benefits.....   | 152        |
| <b>MODULE 11</b>   |            | 13.4 Descriptions and Application Domain .....                         | 152        |
| <b>Contour Ridge Tillage / Farming .....</b>                         | <b>129</b> | 13.5 Implementation of In-Situ Water Conservation Techniques .....     | 155        |
| 11.1 Introduction .....  | 131        | 13.6 Field Maintenance.....  | 157        |
| 11.2 Potential Benefits .....  | 132        |  |            |
| 11.3 Application Domains .....                                       | 132        |  |            |
| 11.4 Investment Costs .....  | 132        |  |            |
| 11.5 Construction of Contour Ridges / Bunds .....                    | 132        |  |            |



# Introduction

The need to urgently improve agricultural productivity has been a major concern for leaders and stakeholders across Sub-Saharan Africa (SSA) nations. There have been many initiatives to address the apparent gap in sustainable natural resources utilization to enhance crop production towards the attainment of food security and improved livelihoods. Weak technological inputs remain key among many issues that have been identified as militating against increasing crop productivity. In many parts of SSA, crop production has continued without sufficient inclusion of appropriate and efficient technologies across the crop production value chain. Whether in the tillage practices, soil nutrient management, pest and disease control or storage and value addition, the use of traditional practices is still prevalent. This trend is still very much observed in the irrigation and agricultural water management sector. There are many reasons for the low deployment of efficient technologies in the agricultural farming system of SSA, which include access to these technologies, financial resources to acquire them, technical capacity and arrays of socio-economic dynamics around the entire production value chain.

The African Development Bank's (AfDB) latest initiative – the Technologies for African Agricultural Transformation (TAAT) - is a bold effort to address several of these production constraints that relate to the deployment and scaling of much needed agricultural technologies in Africa. The TAAT focuses on deploying proven innovative technologies to improve the productivity of different value chains in African agricultural production systems. The TAAT operates under two modes, the commodity and the enabler compacts.

The TAAT Water Enabler Compact (TAAT-WEC) is one of the enabler compacts saddled with the responsibility to scale out proven agricultural water and irrigation technologies across seven countries (Burkina Faso, Ethiopia, Malawi, Mali, Nigeria, Sudan and Tanzania) for five value chains (Rice, Maize, Wheat, OFSP and Sorghum). The TAAT-WEC activities

centred around the participatory demonstration of proven agricultural water management technologies, capacity building of the direct beneficiaries of these technologies and creating an enabling environment to enhance the adoption and scaling of these technologies. As part of the capacity building components of the TAAT-WEC activities, extensive participatory demonstration of the irrigation and water management technologies were conducted. This training manual is a compendium of key bundles of water technologies deployed under the AfDB sponsored TAAT-WEC initiative.

## About This Training Manual

This training manual contains the modules for hands-on training of trainers, extension workers and smallholder farmers on irrigation and agricultural water management. The modules and training approach can be adapted to local conditions. Depending on local conditions, a different training methodology could be adapted to achieve the same objectives set for the modules. There will not be wholesale training of beneficiaries in all the modules in this training manual. Rather, training modules for a particular locality will depend on: (1) existing irrigation and agricultural water management practices; (2) potential to improve on existing practices; (3) current technical know-how of farmers; (4) available water resources for irrigation; (5) availability and accessibility of tools and equipment required for improved irrigation and agricultural water management practices and (6) capacity of farmers to adopt improved irrigation and agricultural water management practices. The role of the trainer will strictly be “facilitation” and training will be conducted according to the participatory extension approach.

## Purpose And Scope Of The Training Manual

This training manual is mainly prepared for making information available and building the capacity of smallholder farmers to be able to adopt improved irrigation and agricultural water management practices. This manual is not a typical engineering or highly technical irrigation training

manual. It is an assemblage of basic information to enable trainers and farmers to understand how they can implement smallholder irrigation technologies. Complex equations and models have been excluded and only simple expressions have been provided in such a way that an average extension worker will be able to use the materials provided. This training manual focuses on enhancing the skills of smallholder farmers to develop available water resources for irrigation, apply water efficiently to crops, manage water efficiently in the field, and manage excess or limited water. It is divided into the following thirteen modules:

*Module 1: Assessing Land and Water Resources for Smallholder Farmer-Led Irrigation Development*

*Module 2: Water Lifting / Pumping Devices*

*Module 3: Shallow Groundwater Tube Well Development*

*Module 4: Runoff Water Harvesting: Farm Pond and Embankment Dam Development*

*Module 5: Closed Pipe Conveyance System*

*Module 6: Surface Irrigation: Basin, Border Strip and Furrow Systems*

*Module 7: Sprinkler Irrigation Systems*

*Module 8: Drip Irrigation Systems*

*Module 9: Irrigation Scheduling with FullStop™ Wetting Front Detectors*

*Module 10: Irrigation Scheduling with Chameleon™ Soil Water Sensors*

*Module 11: Contour Ridge Tillage / Farming*

*Module 12: Laser Levelling - Engineered Surface for Irrigation*

*Module 13: Soil Moisture Conservation Techniques*

The order in which the modules appear does not necessarily reflect the order in which the sessions could be presented in a training. It is expected that the facilitator will prepare session plans to provide a comprehensive background on each of the modules. Each session plan should include the goals and objectives for the session, an overview of the purpose of the session, a description of activities that can be performed to fulfil the objectives, a list of tools and materials required, and the location of additional information.

## Training Approach

The participants of the TAAT-WEC training are adults, young adult extension workers and farmers. To facilitate training, it is important to understand how adults learn, the role of the facilitator in the learning process, and the different participatory learning techniques that can be applied.

## Adult Learning

The use of the Experiential Learning Cycle (ELC) model is recommended for these training sessions. The ELC model recognizes that adults learn differently from children, and thus must be treated differently. These different learning styles are a result of differences in self-concept, experiences, readiness to learn and the application of learning. The experiential learning approach focuses on the learner and his or her discovery of the learning process. It follows a logical sequence called the Experiential Learning Cycle (Figure 1). Adults already have extensive knowledge, skills and experiences, therefore, learning something completely new (experiencing) is not just achieved in an instant. The **Experience Phase** enhances the participants to be involved in “doing” something which is very much related to the real situation, e.g. case studies, role-plays, simulations, lectures, skill practice, slide shows, etc. Adults will always refer back and make use of already acquired knowledge and skills. The **Process Phase** is concerned with participants’ reactions/reflections towards the activity or experience. Participants, with trainers’ assistance, attempt to relate these thoughts and feelings (cognitive/affective) together to derive some meaning from the experience. Sometimes, there may be the need to break apart and review existing knowledge/skills as well as test new ideas. Out of the first two phases of the cycle, participants form conclusions and generalizations which are applicable in real life. This phase is called the **Generalization Phase**. The **Application Phase** provides the participants with the opportunity to give careful thoughts to develop plans to incorporate learnings for more effective future behaviour. The ELC model is especially useful for skills training because most of its techniques are active and designed to involve the participants in skill

practice. It also helps people to assume responsibility for their learning because it demands them to reflect on their experiences.

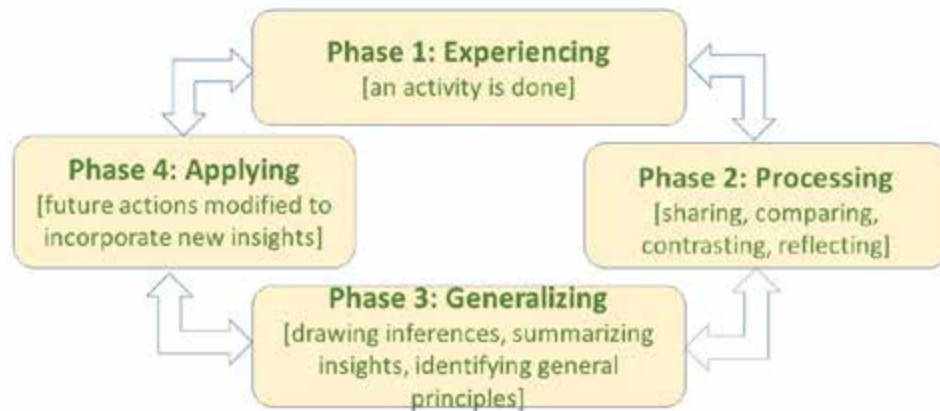

Figure 1: The adult learning cycle (Source: Kolb, 1984).

#### ▪ Role Of The Facilitator

The role of the facilitator in this training program is to create conditions for participants to learn, organize opportunities for participants to observe and interpret differences, and initiate discussions. A good facilitator possesses the following attributes:

- Accepts that there is no monopoly of wisdom or knowledge on the part of the facilitator.
- Listens to farmers and respects their knowledge, experiences and perceptions.
- Gives participants the confidence to share their knowledge and experiences.
- Creates suitable conditions and activities from which farmers can learn.
- Responsive to farmers' needs and flexible in organizing the training.
- Increases farmers' knowledge, skills, problem-solving ability and capacity for innovation.

#### ▪ Facilitation & Learning Techniques

A brief description of the different learning techniques that will be used in the pieces of training is presented below.

##### ▪ Plenary introduction

A Plenary Introduction is normally the first activity to start a new training session. Its main objective is to introduce the subject and familiarize the participants with some basic concepts by referring to familiar and related topics.

##### ▪ Brainstorming

The main objective of a brainstorming session is to introduce new topics and discover new ideas and responses very quickly by having the group describing the topic or idea by listing an exhaustive list of related characteristics and conditions.

##### ▪ Small group discussions

Instead of discussing one subject with the whole group, more subjects can be discussed by using small groups. The main objective is to allow every participant to actively participate in the discussion.

##### ▪ Plenary discussion / presentation

The objective of the plenary discussion/presentation is to synthesize the ideas of the participants about a (new) topic or information that is discussed within the group. A training session using the method of plenary discussion may split up into small groups for small group discussions and continue with a plenary discussion for the formulation of the conclusion.

##### ▪ Practical (field) activities

This allows participants to go to the field and experience a new technology by watching and doing. The objective is to learn through practising new practices.

##### ▪ Field walk/field observations

The objective of a field walk or field observation is to allow participants to learn through observations in the field. The areas to be visited are their fields within their irrigation scheme.

##### ▪ Role-play

In role-plays, participants use their own experiences to play a real-life

situation. The objective of the role-play is to face the participants with (a problem in) their real-life situation, from different points of view and to let them find a solution creatively.

## Training Modules

### Module 1: Assessing Land and Water Resources for Farmer-Led Irrigation Development

#### ▪ Introduction

Water availability is the pre-condition for successful smallholder farmer-led irrigation. Depending on the location of the farm, irrigation water can be obtained from rivers, lakes, dams, surface runoff or groundwater. There is a need to develop the capacity of farmers to sustainably develop water resources available in their locality for irrigation. Farmers will be trained on the specific topics to enable a proper assessment of the land and water resources available within the locality.

#### ▪ Training Objectives

Upon the completion of this module, training participants should be able to:

1. Assess land, water and other required resources as part of planning for irrigation.
2. Differentiate between different water sources available for irrigation, and identify their advantages and disadvantages (including costs).
3. Learn the steps to assess crop water requirements and gross water requirements for the field.
4. Understand the main factors to consider when selecting a suitable location for irrigated crop production.

#### ▪ Expected Outcomes

1. Irrigators will improve their capacity to plan their irrigation and manage available resources

2. Participants will take critical decisions on water sources, water requirements and other variables to enable productive practices.

### Module 2: Water Lifting / Pumping Devices

#### ▪ Introduction

Many smallholder irrigators rely on pumps for lifting water from wells, rivers or ponds/dams. Lifting water requires energy, and this energy is provided either by a petrol or diesel engine with an electric or solar-powered motor. Many different pump types and energy sources exist and selecting the right type of pump and the appropriate energy source is key to successful smallholder irrigation. Farmers should be able to operate and maintain the pump. It is, therefore, important for farmers to be aware of the different available pumps. The small petrol-powered pump is described in detail in this module.

#### ▪ Training Objectives

Upon the completion of this module, training participants should be able to:

1. Differentiate between different pumping devices, and identify their advantages and disadvantages (including costs).
2. Understand the main factors to consider when selecting suitable pumping devices.
3. Select pumping devices suitable for their locality and water source.
4. Follow a step-by-step approach to install, operate and maintain a small petrol-powered surface pump.

#### ▪ Expected Outcomes

1. Irrigators will be able to select the most suitable pump type taking into consideration water sources, conveyance distance, cost, etc.
2. Irrigators will be able to efficiently operate and conduct basic pump maintenance.

## Module 3: Shallow Groundwater Tube Well Development

### ▪ Introduction

Surface and groundwater are the major sources of irrigation water. However, shallow groundwater is easily accessible for farmer-led irrigation within places where the hydrogeological formations support high water yield at shallow depth. Farmers have used manually dugouts to harness shallow groundwater which has not been efficient with high labour demand. This module presents efficient techniques to access shallow groundwater using a tube well and a small gasoline pump.

### ▪ Training Objectives

1. Participants will be able to assess places where shallow groundwater may be feasible.
2. Participants will be able to construct, install a tube well with a gasoline water pump, and conduct pump tests.

### ▪ Expected Outcomes

1. Remove the drudgery associated with manual dugouts.
2. Use shallow tube well technology for irrigation and other agricultural water needs.

## Module 4: Runoff Water Harvesting: Farm Pond and Embankment Dam Development

### ▪ Introduction

Runoff water generated in agricultural watersheds can be efficiently used for productive agricultural purposes. Runoff water harvesting technology enables optimum water use, especially in dry zones with low annual rainfall. There are several approaches to runoff water harvesting however, smallholder farm ponds and dam embankments are feasible within the smallholder landscapes. This module will guide participants on how runoff water harvesting technology can be implemented.

### ▪ Training Objectives

1. Assess the farm watershed to decide on an appropriate runoff water harvesting structure.
2. Differentiate between runoff water storage structures and requirements for their deployments.
3. Adequately design and implement water harvesting structure.
4. Steps in the construction of (1) Farm pond (2) Embankment dam – Check Dam/Clay sandbag.

### ▪ Expected Outcomes

Participants are able to harness runoff water for sustainable agricultural purposes

## Module 5: Closed Pipe Conveyance Systems

### ▪ Introduction

Since agriculture is a major water-consuming venture, water loss during conveyance is of great importance. Water conveyance loss consists mainly of operation losses, evaporation, and percolation into the soil from the sloping surfaces and bed of canals. It is important to provide irrigators with the knowledge and skills necessary to efficiently convey water from the source to their fields. This module elaborates the closed pipe methods of conveying irrigation water, and how to implement them in smallholder irrigation practices.

### ▪ Training Objectives

Upon the completion of this module, training participants will be able to:

1. Differentiate between different water conveyance systems, and identify their advantages and disadvantages (including costs).
2. Understand the main factors to consider when selecting water conveyance systems.
3. Follow a step-by-step approach to design and construct a closed pipe conveyance system.



- **Expected outcomes**

1. Irrigators improve their existing water conveyance systems if already available, and construct new improved ones.
2. New irrigators adopt improved water conveyance systems.

### Module 6: Surface Irrigation: Basin, Border Strip and Furrow Systems

- **Introduction**

Adequate water supply is important for plant growth. When rainfall is not sufficient, plants must receive additional water from irrigation. Various methods can be used to supply irrigation water to plants. However, each method has its advantages and disadvantages. These should be taken into account when choosing the method which is best suited to the local circumstances. Surface irrigation methods are the most common irrigation method. This module captures how these irrigation methods can be efficiently implemented.

- **Training Objectives**

Upon the completion of this module, training participants will be able to:

1. Clearly understand the different surface irrigation methods, i.e., basin, check basin, furrow, and border strip.
2. Identify the factors that determine the choice of irrigation methods.
3. Choose appropriate surface irrigation methods for different irrigated crops.

- **Expected Outcomes**

1. Participants become familiar with different types of irrigation methods, their advantages and disadvantages (including costs).
2. New and existing irrigators adopt efficient irrigation methods, taking into consideration their crop types, soil types, water source, etc.

### Module 7: Sprinkler Irrigation Systems

- **Introduction**

Surface irrigation may be cheap and quick to implement because it gives low irrigation distribution and water use efficiency. Sprinkler gives better irrigation performance and reduces labour demand. Sprinkler irrigation is adaptable to different crops, soil types and landscapes. Different sprinklers exist for use and under diverse conditions. This module introduces the trainees to sprinkler irrigation practices at a smallholder scale.

- **Training Objectives**

1. Understand the basics of sprinkler irrigation practices and how it is operated
2. Differentiate different sprinklers, match the conditions (crop and water needs) and requirements (water source and pressure) for their uses
3. Able to choose the right sprinklers, install and efficiently manage the system

- **Expected Output**

To enable participants to implement sprinkler irrigation in different environmental conditions and cropping systems.

### Module 8: Drip Irrigation Systems

- **Introduction**

In drip irrigation, water is applied slowly at a predetermined rate directly to the crop. Water is supplied in drops or trickles continuously within a period in such a way that the root zone is kept wet. It has a high irrigation and water use efficiency. Drip irrigation components such as emitters and drippers come in different discharges and are for use in different soil properties. This module introduces drip irrigation practices for smallholder farming systems.

- **Training Objectives**

1. Introduce the basics of drip irrigation practices.
2. Identify various components of drip irrigation and how to use them in an irrigation plan.
3. Enable implementation of drip irrigation for smallholders including operation and maintenance.

- **Expected Output**

Enable the farmers to implement drip irrigation at the smallholder level for different crops.

### Modules 9 and 10: Irrigation Scheduling: FullStop™ Wetting Front Detectors and Chameleon™ Soil Water Sensors

- **Introduction**

Irrigation scheduling involves deciding when and how much water to apply to a field. Good scheduling will apply water at the right time and in the right quantity to optimize production and minimize adverse environmental impacts. Bad scheduling will mean that either insufficient water or excessive water is applied or it is not applied at the right time resulting in under-watering or it is applied too soon resulting in over-watering. Under or overwatering can lead to reduced yields, lower quality and inefficient use of nutrients.

- **Training Objectives**

Upon the completion of this module, training participants will be able to:

1. Understand what irrigation scheduling means.
2. Identify the factors affecting proper irrigation scheduling.
3. Understand how irrigation scheduling is determined using the Wetting Front Detector and the Chameleon Soil Water Sensor.

- **Expected Outcome**

1. New and existing irrigators adopt efficient irrigation scheduling methods taking into consideration their crop types, soil types, water source, etc.

### Module 11: Contour Ridge Tillage / Farming

- **Introduction**

Contour farming is a soil water conservation strategy that has benefits for improving soil moisture in-situ and also protects agricultural land from soil erosion. It takes advantage of the land slope in a way that ridges constructed across the slope serve as a conservation structure – like an embankment – to reduce runoff movement, thereby increasing water infiltration. Contour farming is very useful in drylands and can be efficient with a proper land survey for the construction of the contours. This module presents simple land survey practices to aid the implementation of contour farming.

- **Training Objectives**

1. Introduce contour farming, its advantages and constraints.
2. Train participants in the use of simple land survey techniques and tools to facilitate contour identifications in a field.
3. Explain steps in the implementation of contour farming.

- **Expected Outputs**

1. Participants will be able to use simple land survey techniques and tools
2. Capacity to implement contour farming for sustainable crop production in a dry environment.

## Module 12: Laser Levelling – Engineered Surface for Irrigation

### ▪ Introduction

Land levelling is an important practice to establish a level graded land so that surface water advances and is distributed uniformly. It involves shifting soil from the high points of the field to the low points to achieve an even land surface. This session will explore the advantages of land levelling and introduce participants to low-input implements for land levelling.

### ▪ Training Objectives

Upon the completion of this module, training participants should be able to:

1. Identify and analyze land levelling needs.
2. Level land using low-input implements.
3. Introduce a laser-guided land levelling system.

### ▪ Expected Outcomes

1. Farmers adopt land levelling to improve water distribution and prevent waterlogging.

## Module 13: Soil Moisture Conservation Techniques

### ▪ Introduction

In a rainfed system, there are techniques to harvest water in-situ to improve soil moisture availability for crop growth. In-field water management is the manipulation of water within the borders of an individual farm, a farming plot or a field. It generally seeks to optimize soil-water-plant relationships to achieve improved yield. This module discusses some of the techniques to achieve in-situ soil water conservation for soil moisture improvement.

### ▪ Training Objectives

Upon the completion of this module, training participants will be able to:

1. Understand the importance of soil and water conservation.
2. Construct basic on-farm structures to conserve soil moisture.

### ▪ Expected outcomes

1. Participants become familiar with different soil and water conservation methods.
2. Participants adopt appropriate methods to conserve soil and water taking into consideration their crop types, soil types, topography, etc.

## Bibliography

Kolb, D. (1984). *Experiential Learning: Experience as a Source of Learning and Development*. Upper Saddle River, NJ : Prentice-Hall, Inc, p. 256.



# MODULE 1

Assessing Land and Water Resources for Farmer-Led  
Irrigation Development



# Assessing Land and Water Resources for Farmer Led Irrigation Development

## 1.1 Smallholder Farmer-Led Irrigation Practice

Irrigation has become critical to smallholder farming systems to enhance agricultural productivity, adaptation to increasing climate variability, enhanced livelihoods, food and nutrition security in Africa. Using different technologies, water is applied to crops to supplement rainfall. From the common application of water manually with a bucket to the use of small pumps and the deployment of different irrigation technologies, enhancing smallholder farmers with the resources to engage in farmer-led irrigated crop production has become crucial to the transformation of smallholder agricultural systems in Africa. The African Union's Framework for Irrigation Development and Agricultural Water Management (IDAWM, 2020) defines farmer-led irrigation as "[a] process where farmers assume a driving role in improving their water use for agriculture by bringing about changes in knowledge production, technology use, investment patterns and market linkages, and the governance of land and water" (Woodhouse et al., 2017). Farmer-led irrigation relates mainly, but not only limited to smallholder farmers and it is not confined to any one technology. The uniqueness of farmer-led irrigation practices is in the ability of farmers to take charge in improving their use of water for agriculture, making the best decisions on technology choices, investment portfolio, market linkages, and the governance of land and water at their own pace.

## 1.2 Highlights of Smallholder Farmer-Led Irrigation Practices

Considering different available resources across Africa, the African Union has comprehensively addressed major issues relating to agricultural water management in Africa (IDAWM, 2020). It has identified 4 major pathways to improving agricultural water management across the continent. These are:

(1) Improved water control and watershed management in rain-fed farming, (2) Farmer-led irrigation development, (3) Irrigation scheme development and modernization and (4) Unconventional use of water for irrigation.

The TAAT-WEC focuses on Farmer-led Irrigation Development (FLID). The FLID has gained increasing importance in Africa in the last 20 years and it has been identified as the dominant pathway driving agricultural water use expansion in Africa as a major strategy in the food security drive on the continent. Farmer-led irrigation development has the advantage of the immediate accessibility to smallholder farmers who make their investments to advance irrigation and agricultural water management practices. The following are the basic features of a farmer-led irrigation practice:

- Typically grows high-value crops for urban, peri-urban and in some cases, export markets.
- Typically irrigates small plots of 0.5 ha-2 ha.
- Often, but not only, use pumped systems (small petrol, diesel, solar pumps).
- High reliance on shallow tube-wells in the case of individual irrigation systems and water availability within immediate reach
- Mainly horticultural crops.
- Multiple cropping and market-oriented.
- Family labour on smaller plots and use of employed/paid labour on larger farms.

This manual contains 13 modules that provide basic guidance on the planning stage of a successful FLID and technologies that are adaptable to enhance its practices and profitability.





### 1.2.1 Requirement for Small-Scale Farmer-Led Irrigation

Farmers may require land, water and financial resources essential to actively engage in farmer-led irrigation, practices.

- **Access to land:** Either direct land ownership or renting may be considered. The land combines water and soil resources required for cultivation. The available soils may not be of a 'good' quality or with adequate nutrients for crop cultivation. Basic soil analysis is required and should be encouraged to guide the decision on the right soil, water management and appropriate irrigation technology.

However, irrigation services providers are a component of farmer-led irrigation systems that may not need land resources directly for their operation. The service providers may support the main actors in the areas of field assessment, irrigation equipment financing, planning or actual irrigation operation and training.

- **Access to a water source:** Rivers, streams, lakes or reservoirs and shallow groundwater are the immediate sources of water for irrigation



purposes. Having land with good groundwater potential or close to a river or stream is an asset. Depending on the nation's water resources and river water utilization policies, farmers may be free to lift water for smallholder irrigation purposes. This is important when negotiating or deciding on land for agriculture without requiring a water use permit. However, it is also possible for the farmer to construct ponds for water harvesting although this comes with some extra investment (See Table 1.1).

- **Access to finance:** To acquire irrigation equipment, the farmer should have access to funds and/or credit depending on the level of planned production. However, often, there are avenues to access funds that may not necessarily be within the conventional or formal financial systems. Access to credit, government special agricultural intervention funds or loans from financial institutions, cooperative societies, credit from friends and family, special savings, association savings, association guarantee credits etc. are potential avenues. The ability to access a loan and credit might be contingent on collateral and the conditions should be clarified before accepting it. Over the past years, new finance models offered by irrigation equipment suppliers have been developed which do not require collateral. These types of business models may be a lifeline to support farmer-led irrigation actors in securing needed equipment.

### 1.2.2 Assessment of Land, Water and Other Required Resources

There is a need for field assessments to ensure that available land and water resources match irrigation methods and equipment to be deployed. Suitability of the irrigation technologies to the agricultural production systems is critical. Different land and water resource conditions have to be managed and utilized in a way to meet the specific cropping systems requirements. Field evaluation is better conducted by a technical person, perhaps the irrigation equipment supplier, extension officer or an irrigation expert. In the smallholder system, farmers can also conduct some initial field assessments to answer basic questions. This will enable them to make an appropriate application regarding irrigation technology and method,

possible investment cost, best irrigation management practices, projected outputs and revenues.

Some irrigation equipment suppliers render this pre-sales assessment including economic evaluation as part of project planning.

✍ The productivity of investment in irrigation crop production is not limited to the technology but also a host of other variables that must be considered. Table 1.1 highlights the basic resource assessments that are crucial to deciding on investment in irrigation crop production.

**Table 1.1: Features in land and water assessment for Farmer-led irrigation**

| Physical element   | Specific observation   |
|--|--|
| <b>Land</b>  | <ul style="list-style-type: none"> <li>▪ Assess the ownership, land tenure, history;</li> <li>▪ Take the GPS or note a major landmark that can help locate digital information about the area.</li> </ul>  |
| <ul style="list-style-type: none"> <li>▪ <i>Available land area feasibility for irrigation or non-feasible for irrigation</i></li> </ul>   | <ul style="list-style-type: none"> <li>▪ The water source is the main determinant. Is there a reliable water source?</li> </ul>  |
| <ul style="list-style-type: none"> <li>▪ <i>Topography and elevation</i></li> </ul>  | <ul style="list-style-type: none"> <li>▪ Is it hilly or flat land?</li> </ul>  |
| <ul style="list-style-type: none"> <li>▪ <i>History of cultivation</i></li> </ul>  | <ul style="list-style-type: none"> <li>▪ What land-use type, tillage practices, crop type and previous management type in the land</li> </ul>  |
| <b>Water</b>   |  |
| <ul style="list-style-type: none"> <li>▪ <i>Available water sources</i></li> </ul>   | <ul style="list-style-type: none"> <li>▪ Identify water sources close to the land - river, stream, shallow groundwater, lakes, dams with or without canal network</li> </ul>   |
| <ul style="list-style-type: none"> <li>▪ <i>Surface water: River</i></li> <li>▪ <i>Information could be obtained from farmers and people around about the hydrology of the area</i></li> </ul>                 | <ul style="list-style-type: none"> <li>▪ River name, is it perennial or seasonal, what size (how wide and deep), how fast or slow is the flow? With a small dam (sandbags), can you raise the depth of water to achieve pumping all year round?</li> </ul>   |
| <ul style="list-style-type: none"> <li>▪ <i>Distance to the field and where it is located relative to field dimension/layout</i></li> </ul>  | <ul style="list-style-type: none"> <li>▪ Is the water/river/stream easily accessible or needs some conveyance system?</li> <li>▪ What is the distance from the water to the edge of the field?</li> <li>▪ Is the water source close to the middle of the field or close to the edge?</li> </ul>  |
| <ul style="list-style-type: none"> <li>▪ <i>A quick assessment of water quality</i></li> </ul>   | <ul style="list-style-type: none"> <li>▪ Is the water clear, turbid, dirty or smelling? Is the area marshy, or easily accessible?</li> </ul>   |
| <ul style="list-style-type: none"> <li>▪ <i>Groundwater</i></li> </ul>   | <ul style="list-style-type: none"> <li>▪ How deep is the water table; 1m, 5m, 10m or more?</li> <li>▪ At what level is the water table during the peak of the dry season? Do you have farmers using the groundwater for irrigation presently? How is the groundwater being used?</li> <li>▪ What is the average groundwater yield from any pumping outlet nearby? This is crucial if the farmer intends to depend on groundwater for irrigation activities.</li> </ul> |
| <b>Soil</b>  |  |
| <ul style="list-style-type: none"> <li>▪ <i>Soil type (ask questions from farmers around about how they consider the soil - fertile or infertile. Use shovel and dig possibly to a depth of 1m)</i></li> </ul> | <ul style="list-style-type: none"> <li>▪ What is the soil like to a depth of 1m, stones, rock, or soil? What type of soil at the immediate depth(0-30m), organic layer, loamy, gravel, sand, silty, clay? What is it from 30 – 60m?</li> </ul>   |
| <ul style="list-style-type: none"> <li>▪ <i>A quick assessment of soil nutrient/fertility</i></li> </ul>   | <ul style="list-style-type: none"> <li>▪ What is the soil colour? Is the soil sticky when moist? Do you observe earthworms? What type of vegetation is growing in the field, grass, shrubs, trees, etc.?</li> </ul>  |
| <b>Climatic conditions</b>   | <ul style="list-style-type: none"> <li>▪ How will you describe the weather in the field? The pattern of rainfall, dryness, temperature across the year. The onset of rain and when the rain ceases,</li> </ul>   |

| Physical element       | Specific observation  |
|------------------------|---|
| <b>Cropping system</b> | <ul style="list-style-type: none"> <li>What crops are you planning to irrigate and how many hectares per crop? What total area of irrigation and crops do you intend to irrigate in a year?</li> </ul>  |
| <b>Available fund</b>  | <ul style="list-style-type: none"> <li>What is the size of the investment/fund intended for the farm project?</li> <li>Apart from the immediate available personal fund, what other sources of funds are available for the farmer?</li> <li>Is the farmer ready to attract credit financing options?</li> <li>How long is the farmer intending to continue in irrigated crop production? Does the farmer have a history of working successfully on credit?</li> </ul> |
| <b>Credit</b>          | <ul style="list-style-type: none"> <li>Do you already have ongoing loans and credits?</li> <li>How many more loans can the farmer consider either from commodity associations, credit services providers or equipment suppliers? What option is most feasible?</li> </ul>   |

✍ The risk associated with irrigated agriculture can be greatly minimized when careful considerations are given to this information and planning are based on the conditions in the field.

environmental conditions. For instance, in the same environment, sugar cane or maize will require more water than onion or cowpea. To estimate the volume of water for your field, crop water requirement needs to be evaluated to ensure the adequacy of the water source for the entire crop season. Each irrigation event uses a part of this total volume of water. Throughout the crop growing season, the water need for each irrigation event must be satisfied.

### 1.3 Major Considerations for Irrigation Planning

#### 1.3.1 Weather Characteristic

The Crop Water Requirement is influenced by the prevailing weather system and the physiological characteristics of the crop. Weather conditions must be considered when determining the water requirement for irrigation. The reference evapotranspiration, which is the maximum possible water used to meet the evaporation and transpiration demands depends on atmospheric temperature, relative humidity, wind characteristics and solar radiation. These parameters are required in the estimation of reference evapotranspiration. Differences in weather characteristics explain why for the same crop in different locations, the crop water requirement will differ.

✍ This is especially critical when full irrigation is contemplated.

*Irrigation water requirement (IR) and critical period in the crop irrigation:* Without much complexity, Net Irrigation Requirement (NIR) can be computed from the estimated reference evapotranspiration ( $ET_o$ ) for a location, crop coefficient ( $K_c$ ) for the crop growth stage (Figure 1.1 and Table 1.2) and the length of days for the crop development stages (Table 1.3).

#### 1.3.2 Crop Water Requirement

It is important to estimate the volume of water that would be required in a typical irrigation season. This depends on the type of crop and

✍ The reference ET can be estimated using different methods. However, FAO CROPWAT is a tool that can be used to estimate  $ET_o$  with basic agro-meteorological data for the location of interest.

- ✗ The  $K_c$  for most crops has been estimated (Allen et al. 1998) and can be used to do a quick estimation of NIR.
- ✗ However, where available, local crop  $K_c$  data should be used for the NIR estimation.
- ✗ The Net Irrigation Water Requirement (NIR) is the sum of the irrigation requirement for the crop stages – usually, Initial, Development, Middle and Late crop stages).

$$\text{NIR} = (\text{ET}_0 \times K_c \text{ initial stage} \times \text{no of days for the initial crop stage}) + (\text{ET}_0 \times K_c \text{ development stage} \times \text{no of days for the development crop stage}) + (\text{ET}_0 \times K_c \text{ middle stage} \times \text{no of days for the middle crop stage}) + (\text{ET}_0 \times K_c \text{ late} \times \text{no of days for the late crop stage})$$

NIR (mm);  $\text{ET}_0$  (mm)

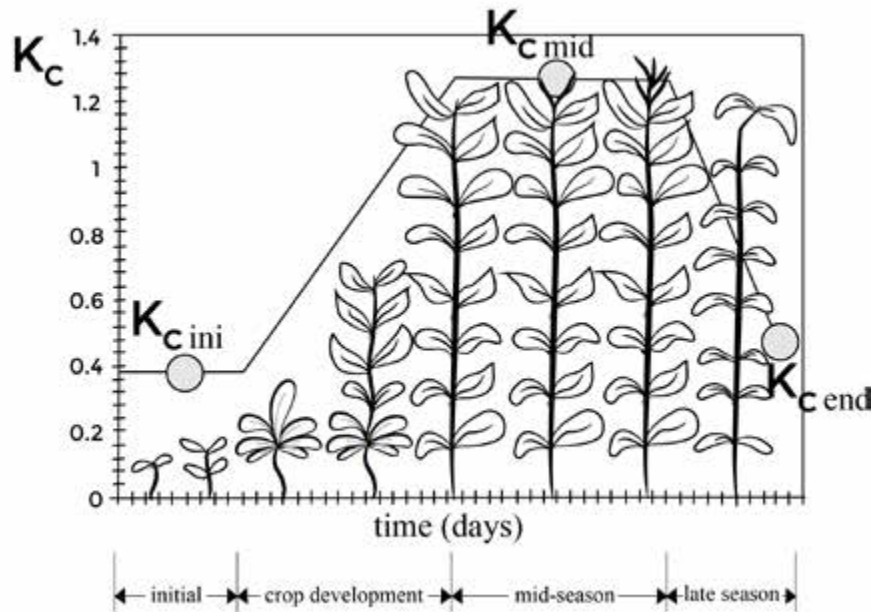

Figure 1.1: Generalized crop coefficient curve for the single crop coefficient (Source: Allen et al. 1998)

Table 1.2: Example of Crop Coefficient of some crops

| Crop               | Kc ini | Kc mid | Kc end      |
|--------------------|--------|--------|-------------|
| Sugar beet         | 0.35   | 1.2    | 0.7         |
| Maize (sweet corn) |        | 1.15   | 1.05        |
| Rice               | 1.05   | 1.2    | 0.90 - 0.60 |

(Source: Allen et al. 1998)

Table 1.3: Examples of the length of crop development stages in days

| Crop                       | Init. (L <sub>ini</sub> ) | Dev. (L <sub>dev</sub> ) | Mid (L <sub>mid</sub> ) | Late (L <sub>late</sub> ) | Total | Plant Date | Region             |
|----------------------------|---------------------------|--------------------------|-------------------------|---------------------------|-------|------------|--------------------|
| <b>a. Small Vegetables</b> |                           |                          |                         |                           |       |            |                    |
| Broccoli                   | 35                        | 45                       | 40                      | 15                        | 135   | Sept       | Calif. Desert, USA |
| Cabbage                    | 40                        | 60                       | 50                      | 15                        | 165   | Sept       | Calif. Desert, USA |
| Carrots                    | 20                        | 30                       | 50/30                   | 20                        | 100   | Oct/Jan    | Arid climate       |
|                            | 30                        | 40                       | 60                      | 20                        | 150   | Feb/Mar    | Mediterranean      |
|                            | 30                        | 50                       | 90                      | 30                        | 200   | Oct        | Calif. Desert, USA |
| Cauliflower                | 35                        | 50                       | 40                      | 15                        | 140   | Sept       | Calif. Desert, USA |
| Celery                     | 25                        | 40                       | 95                      | 20                        | 180   | Oct        | (Semi) Arid        |
|                            | 25                        | 40                       | 45                      | 15                        | 125   | April      | Mediterranean      |
|                            | 30                        | 55                       | 105                     | 20                        | 210   | Jan        | (Semi) And         |

(Source: Allen et al. 1998)

*Gross water requirement for the irrigation season (GIR):* This is the sum of the volume of water that will be required for production throughout the season. The estimation of GIR must be based on the Total Area intended to be irrigated in the irrigation season. GIR is required to assess the adequacy of the water source, either surface (rivers, streams) water, pond, lake or groundwater. Adequacy of water in terms of quantity and quality is very important while planning irrigation projects even at the smallholder scale.

$$\text{GIR} = \text{NIR} \times \text{Crop Area}$$

$$\text{GIR (m}^3\text{)}; \text{ NIR (m)}; \text{ Crop Area (m}^2\text{)}$$

The GIR is an estimate of the volume of water that may be required to

irrigate your cropped field for the entire crop developmental stages. The water to be applied or irrigation depth – during an irrigation event – is a local decision to be determined from the monitoring of the level of depletion of soil moisture by the use of irrigation scheduling tools such as tensiometer, wetting front detector or other soil moisture sensors.

✍ The efficiency of the irrigation method adopted will impact directly on the GIR. For instance, the gross irrigation requirement for a crop under drip irrigation will be much lower than sprinkler and much lower still for the same crop under surface irrigation methods. Similarly, water losses recorded from the conveyance system also affects the gross irrigation requirement.

### 1.3.3 Soil Type

Soil plays a major role in crop cultivation. It provides a reservoir of water and nutrients for plants growth and health. It is also the anchor for plant root as it grows. Different soils have unique characteristics with different properties.

**Soil texture:** The soil consists of primary mineral particles of widely varying sizes. The size distribution of these particles defines the soil's texture. Clay, Sandy clay or Sandy loam are examples of soil textures (Figure 1.2). The soil texture is a soil property that is crucial to irrigation water application and availability for crop use.

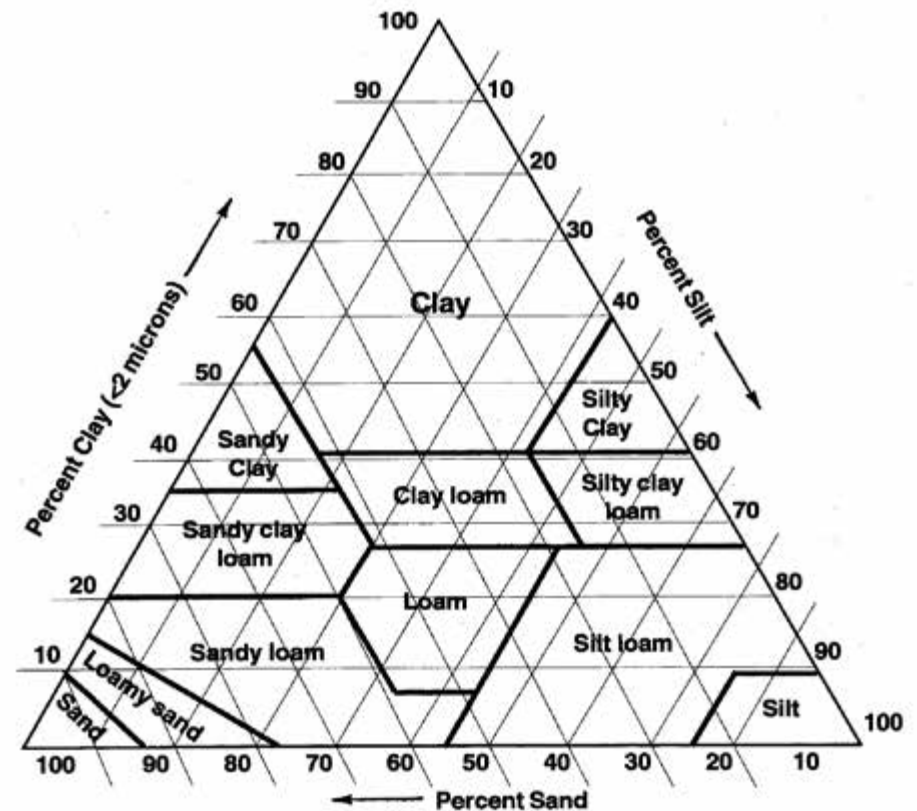

Figure 1.2: Soil textural classes

Table 1.4: Soil texture and infiltration rate

| Soil type  | Basic infiltration rate (mm/hr) |
|------------|---------------------------------|
| Sand       | less than 30                    |
| Sandy loam | 20 - 30                         |
| Loam       | 10 – 20                         |
| Clay loam  | 5 - 10                          |
| Clay       | 1 - 5                           |

(Source: Hala Rawabdeh, 2019)

**Infiltration rates:** Infiltration rates is a soil property that is critical to the decision on the rate at which irrigation water is applied. As a rule of thumb, for all irrigation types, the irrigation application rate or the volume of water applied within a specific time should not exceed the soil infiltration rate for a specific soil textural class (Table 1.4).

**Soil water holding capacity:** The water holding capacity is also described as the available soil water. It is the soil water stored between field capacity (when the soil is fully saturated) and wilting point (the soil moisture level at which moisture is no longer available for plant use leading to plant wilting). Irrespective of the irrigation methods, irrigation events should be scheduled to commence before moisture is depleted to the wilting point. The level of soil moisture depletion can be monitored by soil tensiometer or other types of soil moisture sensors. Module 9 and 10 present the Wetting Front Detector and Chameleon Sensor which can be used to guide the irrigation water application to avoid over-irrigation and decision on when to irrigate.

**Soil nutrient status:** The nutrient requirement for different crops differs. Soil analysis enables an assessment of the available nutrients for crop development. The assessment guides the type and quantity of fertilizers or other forms of soil amendment that may be required. Assessment of soil nutrients will also allow the farmer to estimate the cost implication of the needed fertilizers as a necessary input to ensure that the crop yield potential is achieved.

Other soil properties may be of importance to the evaluation of the soil intended to be used for irrigated crop production. For instance, effective soil depth, salinity, and other soil chemical properties are equally crucial. A soil evaluation should be carried to ensure best management practices for the irrigation practices.

### 1.3.4 Topography

Topography affects what type of irrigation method will be feasible. It influences water conveyance structures and is a big factor in the determination of pump capacity. Therefore, it must be considered before

the choice of a specific irrigation method. For example, surface irrigation is better with a gentle slope (<3 – 5%) however, a sprinkler system is adaptable to different slopes even though a high slope may affect application efficiency and increase pump capacity requirement. In a drip irrigation system, with pressure compensating drippers, drip irrigation can be implemented on different slopes. As a rule of thumb, irrigation is better with nearly level (0 – 3%) to a gentle slope (3 – 5%).

### 1.3.5 Water Source

Water for irrigation can be sourced from the surface (stream and rivers) or groundwater. Factors that will influence the choice of pump type and capacity to be considered include:

- The distance from the water source to the irrigated field – the farther the water source is, the more pumping energy is required.
- Elevation of water source relative to the field – lifting water from deep sources adds to pumping energy.
- Depth of well for groundwater or pond.

This is crucial to determine the placement of pump, suction required and invariably, what pump type will be feasible, practicable and economical for the irrigation.

### 1.3.6 Business Considerations

Irrigation investment usually serves several years. Depending on the quality of equipment and level of maintenance, the investment can serve between 2 – 25 years. For example, a small 5.0Hp used to lift water from a tube well can serve between 3 – 5 years, while a sprinkler system with aluminum pipes can be in operation for 20 years. Similarly, the initial investment in solar water pumping can be high, but such assets can be in operation for between 10 – 15 years with minimum operation or maintenance costs. Generally, the return on investment from irrigation investment is high. However, it is important to consider the different costs, that is Fixed and Variable costs, that will be incurred in the process of irrigation development and crop production. The following elements of the agricultural business and the associated cost must be considered:

**i. Land acquisition and development costs**

The cost associated with land rent, outright purchase, land lease, government programmes/scheme levies, land development - land clearing, preparation, tillage, levelling, etc. should be considered. Land security is required to ensure that investment in the land, water development and equipment installation will be kept for a reasonable period without conflict.

**ii. The cost associated with water access and development**

Often, there may be a need to develop an available source of water to ensure that it is adequate during the peak period for irrigation. Either surface water (rivers and streams) or groundwater, some investment will be required for water development. Therefore, the cost of water rights, digging of wells (open, dugouts or tube wells), building embankment dams or diversion across small rivers or streams, water harvesting farm ponds, as well as the cost of the installation of a pumping system must be considered.

**iii. Equipment acquisition costs**

Depending on the irrigation method that is most appropriate based on the irrigation need (i.e. cropping system) and specific evaluation of the field, some equipment will be required. The major determinants of equipment costs are:

- *Type of irrigation*

Surface irrigation: (furrow, border, basin, check basin) with pumping or with gravity diversion

Sprinkler system: Low- or high-pressure sprinklers, gun spray or travelling gun sprinklers, the materials or pipes line (mainline, sub-mainline, laterals, risers).

Drip irrigation system: What size- the family size of less than 1 acre, or more; the level of controls (manual or automation), system efficiency and command area determine equipment type and the corresponding cost

- *Area to be irrigated*

Although, with higher system efficiency, cost increases, however, the

bigger the area to be irrigated, the more the investment. It is also possible to plan the irrigation project in such a way that the field is irrigated in blocks (BLOCK 1, BLOCK 2... BLOCK 6). Irrigation in BLOCKS enables water to be given to different parts of the field at different times. This makes it possible to use the same equipment across the blocks in rotation e.g., the use of travelling gun sprinklers or mobile conventional sprinkler systems.

|         |         |
|---------|---------|
| BLOCK 1 | BLOCK 2 |
| BLOCK 3 | BLOCK 4 |
| BLOCK 5 | BLOCK 6 |

**iv. Operation and maintenance cost**

At whatever scale of irrigation operation, there are costs associated with the operation of an irrigation system. This must be estimated and planned to avoid challenges in the course of production. These costs include:

- *Labour costs:* This is for the movement of equipment (e.g. laterals and risers for sprinklers, water diversion, siphon operation etc.). The smallholder farmer may be directly involved in these operations, however, where a farmer intends to use outside labour or hired personnel, the cost must be estimated for the season.
- *Energy cost:* Except where the energy source is a solar system, electricity and fuel-powered pumps attract cost for their operation. The cost of fuel for irrigation water pumping may be very significant as part of the operation cost. This is a major reason why investment in solar irrigation systems certainly has a higher economic advantage over time. Where possible, smallholder farmers should be encouraged to take advantage of different feasible business models to invest in solar irrigation to reduce energy costs which could impact positively economic productivity.
- *Maintenance costs:* It is important to prepare also for the cost of maintenance of equipment. For instance, pump servicing, repair



of lines etc. These are costs that may arise unplanned and may be required at a very critical period of the irrigation season.

v. *Agronomic and crop production costs*

The agronomic and crop management practices are critical to achieving the high potential that irrigated crop production promises. In planning, therefore, different costs associated with crop agronomic management and labour (tillage, planting, fertilizer and pesticides application, weeding, and field management) from planting to harvest must be carefully considered. Often, when the right inputs e.g. seed, fertilizers, pesticides, etc. are not applied when needed, crop performance and yield will be affected even when irrigation efficiency is optimum. The cost of harvesting and processing crops must equally be considered.

vi. *The cost associated with storage, processing and transportation of produce*

Before embarking on irrigated crop production, it is important to also consider the cost of transportation and storage of the produce. Some crops are storable while others have a very low shelf life. For instance, leafy vegetables, horticultural crops and fruits have to be sold as quickly as possible except if a good storage structure is available. Similarly, poor roads and logistics of getting products to the market must be considered as part of the irrigation planning even for small scale production.

vii. *Market*

For the farmer to be able to recover the invested costs, access to the market for the crop produced is very important. Often, farmers fail to carefully consider and plan with the market or off-taker in mind such that they can get maximum benefit in terms of good pricing for their products. Farmer-led irrigation systems have the advantage of flexibility as regards the decisions on choice of the crop as business climate dictates. Access to market information will help the farmer in the choice of crop. Costs associated with produce marketing – for instance, packaging and transportation – should be equally considered.

## Bibliography

Allen, R. G., Pereira, L. S., Raes, D., & Smith, M. (1998). FAO Irrigation and Drainage Paper No. 56 Crop Evapotranspiration. FAO Rome

Brouwer, C. & Heibloem, M. (1986). Irrigation Water management Training manual no. 3 FAO Land and Water Development Division

Lankford, B. (2009). Viewpoint – The right irrigation? Policy directions for agricultural water management in Sub-Saharan Africa. *Water Alternatives* 2(3), 476-480.

Woodhouse, P., Veldwisch, G. J., Venot J. P., Brockington, D., Komakech, H. & Manjichi, A. (2017). African farmer-led irrigation development: re-framing agricultural policy and investment? *The Journal of Peasant Studies*, 44(1), 213-233.

# MODULE 2

Water Lifting / Pumping Devices



# Water Lifting / Pumping Devices

## 2.1 Water Pumping from Rivers and Other Open Water Sources

Irrigation water can be sourced from groundwater or surface water. Surface water sources include rivers, streams, canals and ponds. Outside of the irrigation schemes where water is conveyed in canals under gravity. Nearly all other water sources require a type of pumping to make the water available in the farms where it is needed. Often, farmers are not quick to take advantage of the rivers and streams around them for agricultural purposes; either because of the low capacity to operate appropriate pumps efficiently or some farmers are still fixated on rainfed agriculture. In many instances, around the smallholder agricultural system, not many restrictions are placed on pumping from either seasonal or rivers that flow all year round. The major challenges have always been the capacity and the cost to introduce pumping technologies or water-lifting devices for enhanced irrigation water access (see Figure 2.1).

Pumping is a technique in which a mechanical device (pump) is used to move fluid to the desired point with increased energy. Pumping enables the fluid to gain more pressure and move a high volume of fluid than what can be done manually. It makes it possible to move the fluid against gravity and attain height or further distance than what would have been possible without the extra energy supplied by the pump. Pumps require energy for operation. This energy comes either from a combustion engine using fuel or solar power or electricity from the grid. The energy required for pumping comes with extra operational costs e.g., the cost of diesel, petrol, oil and electricity. Therefore, caution must be taken to choose the right pump to deliver the required output efficiently with less power demand and a reduction in the environmental impacts including greenhouse gas emissions (e.g., CO<sub>2</sub>).

Although the science of pumping is wide, an attempt is made in this module to provide basic information that will enable a smallholder farmer

to deploy pumping technology at a small scale and with little complexity or technicality. This module will enable extension officers to guide the smallholder farmers in the choice and use of small capacity water pumps. It covers basic knowledge of pump types, selection, installation, operation and maintenance practices within the smallholder farming systems.

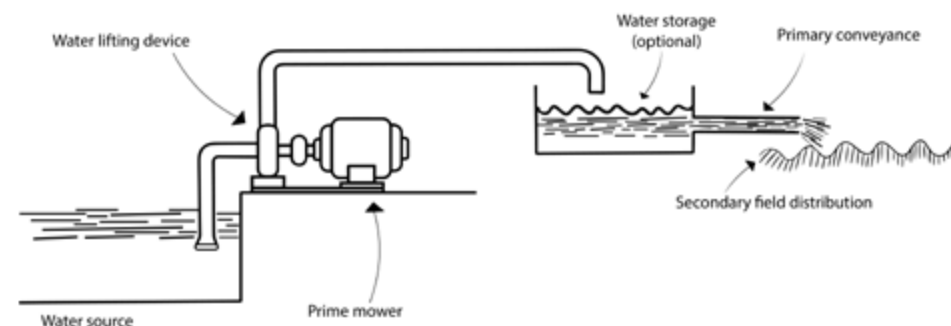

Figure 2.1: Typical water pumping system (FAO, 1985)

## 2.2 Potential Benefits

The major advantage of pumping is the ability to supply the energy required for water lifting and moving over limiting factors such as gravity and topography. Pumps also ensure that the required pressure to drive irrigation equipment can be achieved. The traditional manual water-lifting is quite limiting. It is estimated that a strong man may be able to deliver about 75W (0.1Hp) of power. This implies that about 10 men may be needed to achieve what a 750W (1.0Hp) pump will deliver. Pump energy, therefore, allows for huge power to be produced for water lifting, thereby reducing labour requirement per unit area for irrigation water application. This allows for a significant increase in the possible areas a farmer can cultivate and equally enable the use of irrigation devices that require pressure for efficient operations. Pumping machines are equally capable of operating for long hours as against human capacity. For instance, it has been reported that the common small fuel-powered pump is a key to the expansion of cropped areas among farmer-led irrigation actors across Sub-Saharan Africa (Regassa et al., 2013).

### 2.3 Investment Costs and Profitability

The cost of pumps depends on the capacity in terms of discharge, total head<sup>1</sup> and energy source. Although smallholder farmers find small fuel-powered pumps more adaptable to the different agricultural environments, the overhead or operational cost for fuel-powered pumps is much higher than that of the solar-powered system (FAO, 2014). The small motorized pumps – driven by small petrol or diesel engines with a capacity of 2 to 8 horsepower (hp) with a typical discharge of 2–20 ℓ/s – have proved effective for smallholder farmers and allow them to irrigate a substantial area of 1 to 2 ha (Namara et al., 2014). These types of pumps typically cost between US\$200 and US\$500. Increasingly, more smallholder farmers are turning to these categories of pumps for their operations. However, high maintenance and operational costs – essentially fuel costs – and environmental pollution (CO<sub>2</sub> emission), remain the low side of these small pumps (Otto et al., 2018).

#### *Benefits of a solar pumping system*

The electric pumps linked to the solar energy units could be more reliable with low maintenance costs. Solar pumps allow users to avoid the constraint of the fuel costs required in the use of motorized pumps. Although energy outputs of the solar system may fluctuate as insolation changes with cloudiness. However, in smallholder irrigation systems, especially with drip irrigation, water supply can be improved by using water storage tanks that are filled at peak energy times. Pumping into a storage tank can be a great support for a smallholder farmer investing in solar pumping who may then be able to irrigate between 0.3 and 1 ha (FAO, 2014). A small-scale complete irrigation system – submersible pump, 300 W panels on secured 3 m high stand with controller, filters and 1-acre drip irrigation, with planning, installation and guarantees for the pump, panels and drip lines cost about \$2,400 (Hans & Lucie, 2018). Investment cost per hectare for solar pumping is reducing with different business models and plans being offered by solar technology enterprises (Otoo et al., 2018). Operational and maintenance costs for a solar-

<sup>1</sup> Total pump head = static head + frictional loss in the pipe and fittings + Pressure (Discharge) head

powered pumping system are very low at 50–100 US\$/ha. Maintenance operations involve, essentially, cleaning of panels and troubleshooting electrical fittings. It may be worthwhile for farmers to consider the long-term investment benefits of using solar energy to pump irrigation water. These advantages also include environmental friendliness, reduction in greenhouse gas emissions and noise pollution.

### 2.4 Applications Domains

The use of a pump for river water lifting is adaptable to different terrains. There are different types of pumps that can be used in river water lifting for smallholder farmer-led irrigation. However, the applicability and choice of a type of pump depend on different factors. Table 2.1 and Figure 2.2 show different types of pumps adaptable for irrigation purposes under different conditions (insert reference).

**Table 2.1: Some pump types adaptable to smallholder irrigation**

| Type   | Basic description   | Applicable scenario   | Power Source                          |
|--|---|---|---------------------------------------|
| <b>Floating submersible</b>                  | This pump is hanged on a float/raft   | Where the water depth fluctuates with time e.g., pond or seasonal rivers  | Electricity or solar-powered          |
| <b>Turbine/ Shaft pump</b>                   | A turbine pump is essentially defined as a centrifugal pump that is mounted underwater and then connected to a motor above the water by a shaft.  | Turbine pumps lift the water through the pipe that contains the shaft and the water exits underneath the motor. Turbine pumps are very efficient and excellent for large areas.                           | Electricity or solar-powered          |
| <b>Submersible (different designs exist)</b> | The submersible pump has both the pump and the driving motor fused as a single unit which can be completely embedded in the water for pumping operation.  | It pumps from the belly of a water body. It is suitable for groundwater rivers or ponds/ tanks pumping.   | Electricity or solar-powered          |
| <b>Displacement</b>                          | This pump moves water by displacement. Examples include piston pumps, rotary pumps, and diaphragm pumps.  | This pump type is suitable in shallow groundwater, canal water lifting and where pumping is from low elevations.  | Manual, fuel engine                   |
| <b>Centrifugal pump</b>                      | This pump type uses an impeller to spin the water rapidly inside a special housing, and the force created by this moves the water out of the pump. They can be single or multi-stage and need to be primed before they are first used. It comes in different designs, shapes and capacities | It is adaptable to many landscapes. River water lifting, shallow groundwater, ponds, tanks etc. The main consideration is the pump suction head which should not exceed the manufacturer's specification. | Electricity, solar power, fuel engine |

Many other types of pumps may also be considered for different uses, however, not all pumps can be easily used by smallholder farmers within the landscape due to their limited technical competencies.

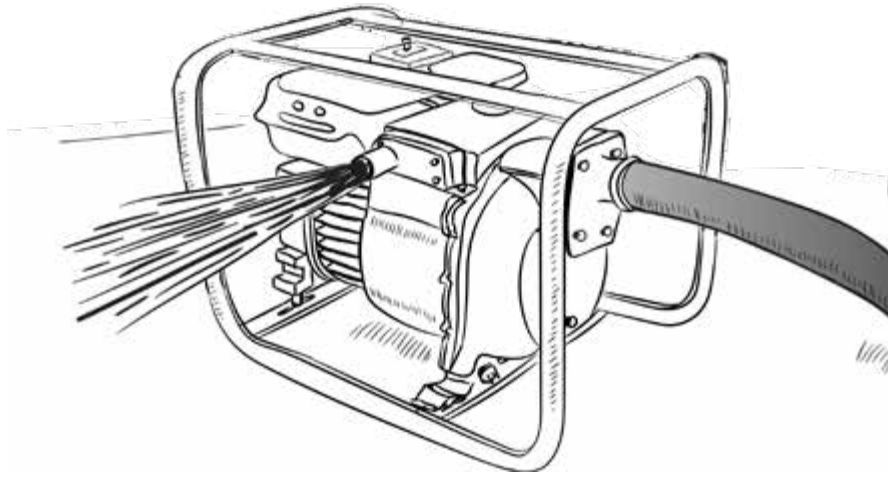

Centrifugal fuel-powered pump

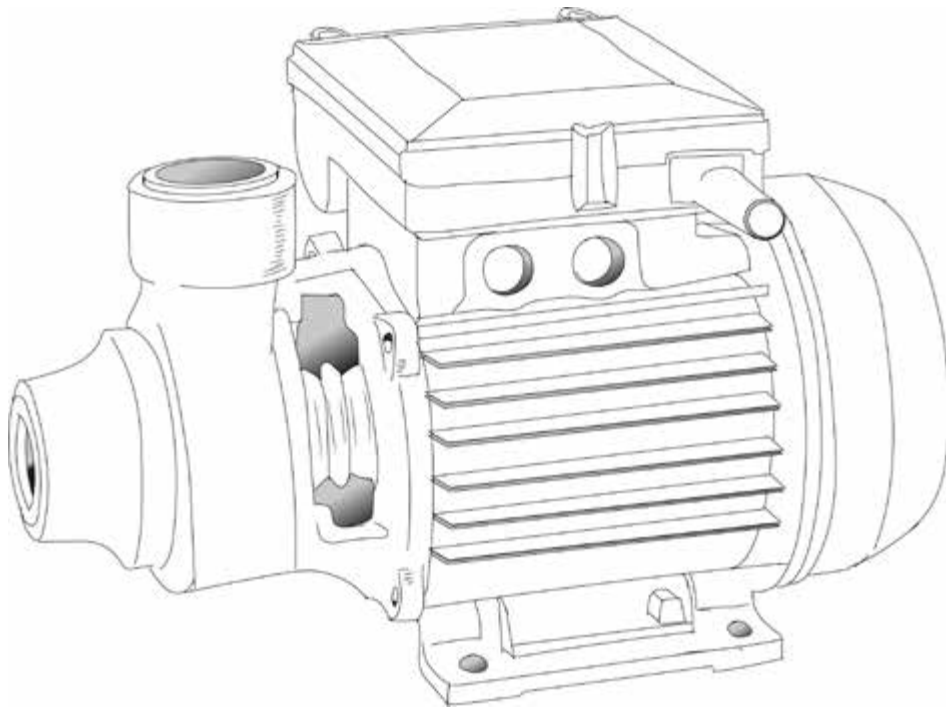

Surface electric pump



Submersible electrical pump

*Figure 2.2: Examples of pumps used in irrigation*

River water pumping is adaptable to the irrigation of different crops with different irrigation methods most appropriate in a particular environment. Pumping can be used to lift water with enough head or pressure from different sources for surface, sprinkler or drip irrigation systems for the production of rice, wheat, maize, sugar cane, grasses, vegetables, etc. River water-lifting using an appropriate pump can completely transform smallholder capacity to better utilize water resources within their farm area and increase their irrigable commands. The initial cost, however, may be the greatest challenge for smallholder farmers.

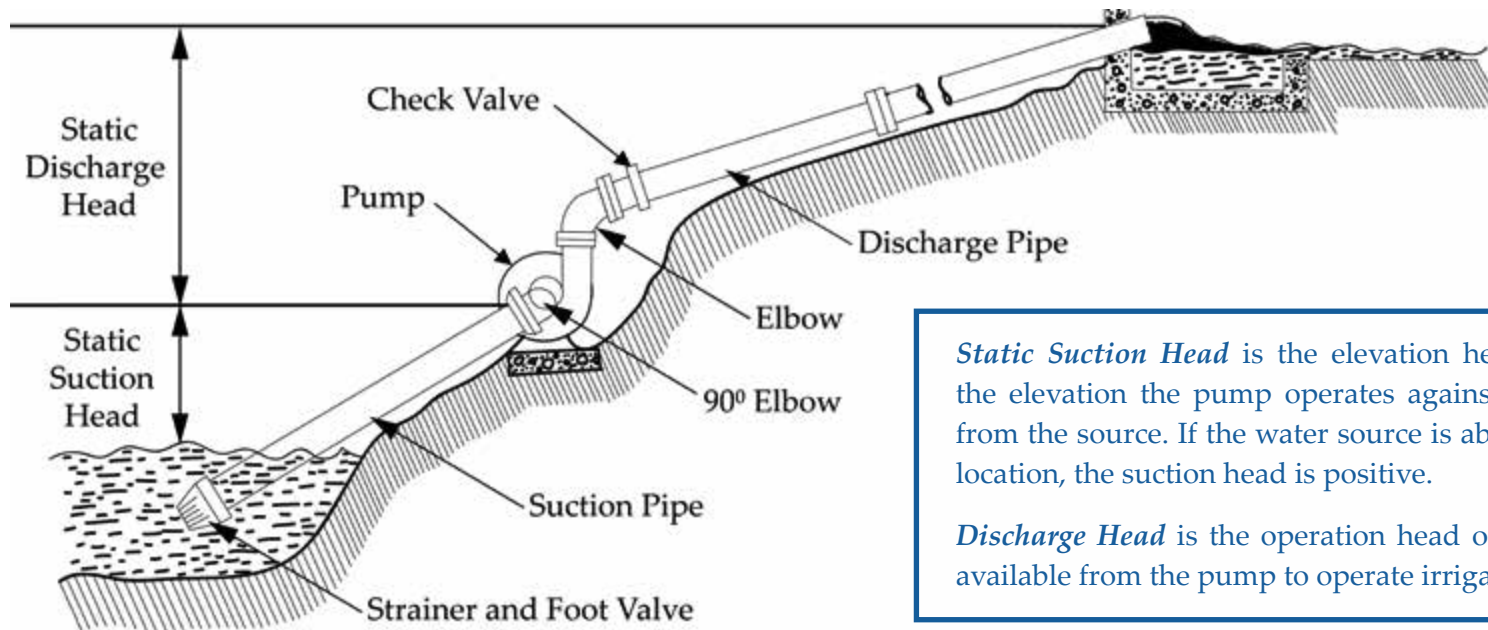

*Static Suction Head* is the elevation head. It defines the elevation the pump operates against to lift water from the source. If the water source is above the pump location, the suction head is positive.

*Discharge Head* is the operation head or the pressure available from the pump to operate irrigation devices

Figure 2.3: Basic layout of a typical surface water pumping (FAO, 1986)

## 2.5 Pump Selection Consideration

This manual considers pumping from a river and shallow groundwater that require cheaper pumping costs compared to deep groundwater.

River water flow fluctuates between seasons and with a response to rainfall-runoff characteristics of a catchment. During the wet period, the flow in the river is often high and pumping could be much easier. However, during the off-season or dry season, there is low flow even in perennial rivers. There may be a need to build a small dam across the river to be able to impound the flow for pumping, especially during the dry season or when there is low flow.

This module focuses on surface water pumping within the smallholder systems with field sizes between 0.5 – 2.0ha. To select an appropriate pump, it is important to consider:

1. The water source from where the pump will lift water i.e., river, pond, groundwater etc.
2. The required pump discharge capacity to meet your irrigation need. This is estimated based on the water requirement for the irrigation system to be operated. For instance;
  - For surface irrigation - the volume of water for the surface irrigation e.g., stream size or flow rate from a gated pipe for furrow irrigation and how many furrows would be fed at the same time.
  - Sprinkler irrigation - the number of sprinklers and individual sprinkler discharges.
  - Drip irrigation – the number of drip lines and emitter rates of individual drippers/emitters.
3. The field elevation and distance to the mainline. These considerations are further explained in Table 2.2



**Table 2.2: Considerations for pump selection**

| Observation  | Consideration   |
|--|---|
| Depth of the river/pond to the river bank or field level | <ul style="list-style-type: none"> <li>▪ Pump level from the farm/land surface to the river should not exceed 6m. This is the suction head of the pump (Figure 2.1). This is acceptable to most small centrifugal pumps used in farmer-led irrigation practice.</li> </ul>  |
| Fluctuations of the river water level                    | <ul style="list-style-type: none"> <li>▪ Ensure suction is sufficiently submerged in water always.</li> <li>▪ This should guide the placement of the suction end/line of the pump to ensure it reaches water during operation.</li> <li>▪ High fluctuations may be a reason for using a floating pump system.</li> </ul>              |
| The volume of water required                             | <ul style="list-style-type: none"> <li>▪ Volume or pump discharge rate should be noted.</li> <li>▪ Can the river yield the estimated volume of water to be pumped?</li> <li>▪ You may need a temporary dam as part of river development.</li> </ul>   |
| On-farm storage (pond or tank)                           | <ul style="list-style-type: none"> <li>▪ This could be needed as temporary storage to buffer pumping variations if the investment is feasible.</li> <li>▪ It may be required for drip irrigation systems.</li> </ul>  |
| Available power (electricity, fuel)                      | <ul style="list-style-type: none"> <li>▪ Electricity power from the grid is cheaper than the cost of fuel.</li> <li>▪ Solar is renewable but the initial cost should be considered.</li> <li>▪ The fuel-powered pump may be an easy or immediate option but comes with operational costs and pollution to the environment.</li> </ul> |
| Proposed investment                                      | <ul style="list-style-type: none"> <li>▪ How much is the farmer willing to invest?</li> <li>▪ This guides command area, pump type and size, irrigation methods and field layout or installations.</li> </ul>  |
| Irrigation area and crop water needs                     | <ul style="list-style-type: none"> <li>▪ The bigger the area, the more water to be pumped. If crops with high water demand are considered, it increases water need per unit area.</li> </ul>  |
| Level of land ownership                                  | <ul style="list-style-type: none"> <li>▪ This affects the safety and the guaranteed period of operation without interference which is needed in the determination of what investment can be put on the land.</li> <li>▪ Can a farmer use permanent pump installation, buried pipe system, etc. or not?</li> </ul>                     |

**Before deciding on a pump, make sure it can deliver these two outputs**

1. The Discharge Requirement - This is the volume of water the pump can deliver per unit time. (See Module 1 for the estimation of irrigation requirement)

2. The Total Head (Equation 1) – This is a measure of the maximum pressure that the pump should deliver for an efficient operation of the irrigation system. Pump manufacturers usually give the possible Total Head for a specific pump brand (Figure 2.2).

**TOTAL HEAD ( $H_t$ ) = Elevation head ( $H_a$ ) + sprinkler/Emitter operation pressure head ( $H_i$ ) + Friction losses Head ( $H_p$ )..... Equation 1**

$H_a$  = Elevation head (Distance/Depth from the Water surface to the pump eye)

$H_i$  = Operation head for the emitter, sprinkler (usually specified for the device). 10m Head is equivalent to approximately 1bar.

$H_p$  = Friction head losses. The sum of friction losses in the mainline, sub mains, manifolds, laterals, valves, pipe fittings and minor losses make the Friction losses head. For ease of estimation, it may be set at 10 – 20% of the total head requirement.

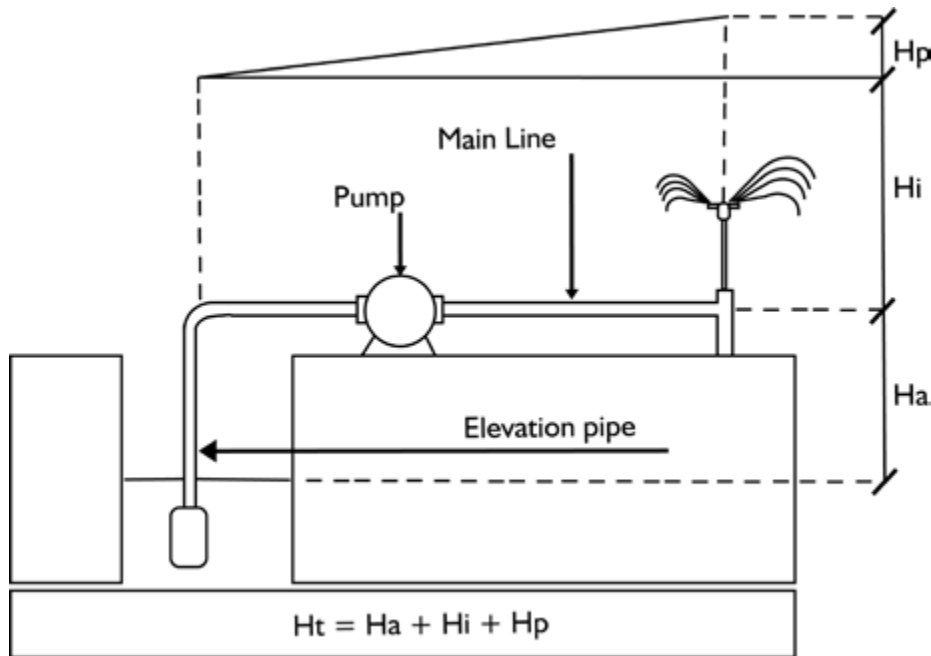

- $H_t$  = Total Head
- $H_a$  = Elevation or suction head
- $H_i$  = Operatison head for Emitters or Sprinklers
- $H_p$  = Friction losses head

### 2.5.1 Irrigation Methods and Pump Capacity

This depends on the type of irrigation methods, the areas to be irrigated at a time, the distance to the water source and possible irrigation water application rate (field discharge required per unit time). Table 2.3 can be used to guide the selection of fuel-powered motorized surface centrifugal water pumps. Three conditions may require the choice of a bigger pump or more pressure. For instance, conveying water over a far distance, if a sprinkler system (in large numbers with high application rate e.g., gun sprinklers) is preferred and if pumping is expected against significantly high elevation, then the bigger pump should be chosen for the same area. Sprinkler irrigation always requires more pressure and thus, more energy. Although these factors have to be properly worked out in situations beyond small fields (more than 2.0ha), for drip irrigation, different ancillary facilities may be required for optimum performance. For instance, if drip irrigation is intended, the pump size to be selected may be used for lifting water to a storage tank (for a small field size) connected to a drip system.



- ⚠ When a farmer considers sprinkler or drip irrigation systems and if a farmer intends to cultivate more than 2 ha, professional support should be sought from equipment suppliers, local extension officers or an irrigation consultant engineer/service provider.
- ⚠ This is necessary to properly assess the field, water source, topography, elevation, and crop water requirement to enable appropriate technical decisions.

**Table 2.3: Irrigated area and pump outlet diameter for different irrigation methods based on fuel-powered centrifugal pumps**

| Area (ha) | Irrigation methods and pump outlet diameter <sup>2</sup> (discharge end) |                  |                            |
|-----------|--|------------------|----------------------------|
|           | Surface irrigation(inch <sup>3</sup> )                                   | Sprinkler (inch) | Drip (inch)                |
| 0 – 0.5   | 2  | 2 or 3           | 1 or 2 (with storage tank) |
| 0.5 – 1.0 | 2 or 3   | 3                | 2 (with storage tank)      |
| 1.0 – 1.5 | 3  | 3 or 4           | NA                         |
| 1.5 – 2.0 | 3 or 4   | 4                | N/A                        |

**NOTES:**

The information available in Table 2.3 is based on the commonly available fuel-powered centrifugal pump. Table 2.3 can be used to guide pump selection for an irrigated area of fewer than 2.0 hectares.

When the field is flat, the suction end is low and the distance to the field is quite minimal, the pump performance will be better delivering good discharge and pressure.

The pump can deliver more pressure to the system by reducing the outlet diameter with a reducer socket. This may be needed if more pressure is required for operation in the field.

inch: 1 inch = 25.4mm. Farmers and small pump dealers are quick to describe the small pumps with the outlet diameter sizes in “inches”.

Pumps have different engine capacities, discharge, and maximum lift. Farmers are quick to associate the pump diameter of the discharge outlet to pump capacity and power. This is the reason for providing Table 2.3 in “inches” – diameter of the discharge and possible pipe to be used as mainline with the pump. Generally, pumps come with the manufacturers’ technical specifications usually fixed on the side of the machine. For instance, a typical 2 inches petrol pump comes with specifications as can be found in Table 2.4.

**Table 2.4: A typical pump manufacturer’s specification and interpretation**

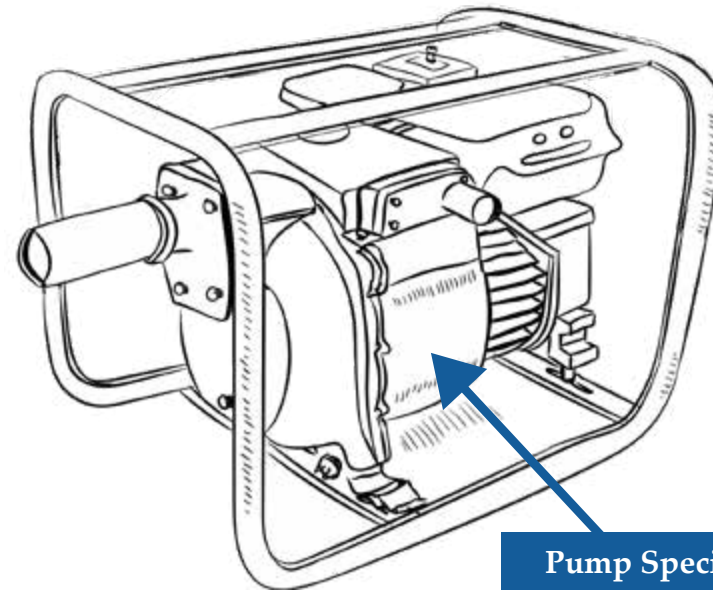

**NOTE:**

Other pump types have similar specifications tables. For an electric-powered pump, information about the type of electricity (DC or AC) input current and voltage range among others will be provided. Where necessary, advice of technical personnel should be sought to avoid risks to life and destruction of equipment.

| Pump Specification             | Interpretation   |
|--------------------------------|--|
| Inlet / Outlet diameter: 50 mm | The diameter of the discharge outlet                             |
| Rated output power: 5.5 HP     | This is the capacity of the engine                               |
| Rated speed: 3600 rpm          | The speed of the engine. This particular engine is a high speed, |
| Fuel tank capacity: 3.6 L      | Fuel tank capacity   |

| Pump Specification                      | Interpretation   |
|---|--|
| Maximum Head: 30m                       | This gives an idea of the pressure. Head of 10m is equivalent to approximately 1bar of pressure. Pressure decreases with the distance and height against which the pump operates |
| Maximum Suction head: 8 m               | Max distance/depth from the water source at the suction. It is safer to work with fewer figures than specified   |
| Maximum Flow rate: 35 m <sup>3</sup> /h | The water discharge rate   |
| Noise emission: 111 dB                  | Noise level  |

(Source: <http://www.portable-gasolinegenerator.com/sale>)

### 2.5.2 Energy Concerns

The source of energy for pumping can also increase the irrigation operational cost. For a smallholder, fuel and solar-powered pumping are the most feasible. Where possible, electrical pumps can be a major cost-saving option. However, electricity may not be available in rural environments. Solar-powered pumps presently have a high initial investment, but over time, could be a better option because they come with very little operational costs. Petrol- and diesel-powered pumps are most common, easily affordable even though they have significant operational costs from fuel and maintenance. The information provided in this module is based on the commonly available fuel-powered small centrifugal pumps.

### 2.5.3 Design and Installation Requirements

Some basic components of a smallholder pumping system are listed in Table 2.5.

**Table 2.5 Descriptions of pumping system components**

| Item                              | Description  |
|-----------------------------------|--|
| Pump                              | Determine the pump outlet diameter using Table 2.3 as a guide. You may ask an irrigation equipment dealer or service provider.   |
| Suction end                       | The hose or pipeline for suction should not be beyond 6m for most motorized surface centrifugal pumps.   |
| Suction 1-way foot valve/strainer | To aid priming of your pump, install a 1-way foot valve with a strainer at the suction end. This will help retain water in the suction line.   |
| Discharge end/hosepipe            | This can be a flat hose or connected to the mainline pipe (Galvanized, Aluminium, HDPE or PVC).  |
| Coupling devices                  | Pumps from different makers come with unique coupling devices. Ensure you have appropriate coupling devices that will not give in when the pump is in operation.                                 |
| Field application line/hose/pipe  | Depending on the conveyance system employed for field water application, ensure that the discharge hose/pipe is connected to the field line (mainline) or discharges to the right-field channel. |
| Gate valve (optional)             | This may be required just to control flow into the mainline.   |

### 2.6 Basic Steps of Pump Installation and Operation

Six basic steps to guide the installation of small pumps are presented below.

**Step 1:** Preliminary assessment of field, materials and equipment needs

- Locate your water source; river, stream or pond.
- Ensure that the depth to a possible base of your pump does not exceed 6m.
- Take basic measurement of water sources depth, possible place/base for your pump.
- Measure the distance from the pump to your field. This will guide the pump size to buy, the suction hose length and the discharge hose.
- When buying your pump, seek advice from the pump dealer on appropriate coupling devices. There are various types and designs of coupling devices.

**Step 2:** Decide if you will make the installation permanent or temporary

- Consider the safety of equipment (pump, pipes/hose) and any other field materials.
- Remember security of equipment against theft!
- Consider the season. If in the rainy season, ensure your motorized surface pump is not placed where a flood can submerge it and where water is too shallow to avoid pump damage by silt.

**Step 3:** Secure a base for the pump

- Ensure a firm base to reduce vibration. Vibration can cause damage to the pipe joints or connections.
- One practical way to reduce the vibration for a small motorized pump is to sit the pump on a used rubber tyre. The weak base can result in the tilting of the pump and this may damage the connections.

**Step 4:** Connect the suction and discharge lines

- The suction line should be installed with a strainer or foot valve at the end to avoid sucking objects into the pump.
- Make sure the various coupling devices are appropriate for your use.

- To avoid too many breakdowns during operation, ensure firm connections.

**Step 5:** Ensure discharge end/line is connected to the conveyance pipe or field canal

- To avoid wastage of water, time and other resources, ensure that the discharge outlet and all the fittings are properly fixed.
- Connect to your conveyance structure and the irrigation networks appropriately in the field.
- Water comes with pressure and could create erosion if in the wrong place.

**Step 6:** Start your pump with proper priming

- Fill the pump casing with water through the priming hole on the pump.
- Start the pump and ensure all the connection is intact.
- Attend to whatever needs your attention promptly.

**2.7 Pump and Irrigation System Troubleshooting**

Few conditions often arise when operating fuel-powered small pumps. Some of the common situations and possible issues to consider are listed below.

| Observed condition                             | Possible issues to address   |
|--|--|
| The pump is not lifting water                  | Ensure the pump is properly primed. Increase the engine speed reasonably. Check that the suction end is fully submerged.   |
| The pump is lifting water but not continuously | Check that the suction end is not blocked with sediment. Avoid pump suction being submerged in silt or turbid (high sediment loaded) water.  |
| The pump engine is not working                 | Check that there is fuel in the tank. Check the oil gauge as well. If the problem persists, you may request for a maintenance technician to further check the fuel or electrical system of the engine. |

| Observed condition         | Possible issues to address  |
|----------------------------|---|
| Pump is vibrating          | Make sure that the pump seats are balanced well. You may damp the vibration by placing the pump on a used car tyre. |
| Pump discharge is bursting | Check the connection fittings to the mainline.  |
| Pump discharge is low and  | Ensure the suction end is fully submerged in the water. Increase the engine speed reasonably.                       |

### PLEASE NOTE

- ✍ Do not shy away from asking questions from your extension officer or irrigation equipment supplier about any aspect of your intention to use motorized pumps in your field. You can also learn from colleague farmers who may have used this technology around you.
- ✍ When your field exceeds 2ha, you surely will need to contact these aforementioned professionals who may provide technical guidance. This will help you cut cost and ensure best practices that will guarantee efficiency and good operational life for your systems.

### Link to Installation Videos

Pump installation and demo. 5.5hp Petrol Engine Water Pump Riequip: [https://www.youtube.com/watch?v=ODk\\_iBa2sk](https://www.youtube.com/watch?v=ODk_iBa2sk) (Accessed December 5, 2020)

### Disclaimer

The mentioning of any equipment brand, illustrated or explained in this module is for the purpose of training. The IWMI does not promote any brand of equipment and will not take responsibility for the choice of any brand.

### Acknowledgement

All the illustrations used in this manual have been appropriately cited. Any omission is, hereby, highly regretted. The Riequip YouTube channel is acknowledged for the installation video.

### Bibliography

FAO (1986). Water Lifting Devices. FAO Irrigation and Drainage Paper 43, Food and Agriculture Organization of the United Nations, Rome, Italy.

Hans, H. & Lucie, P. (2018). The benefits and risks of solar-powered irrigation - a global overview Published by the Food and Agriculture Organization of the United Nations and Deutsche Gesellschaft für Internationale Zusammenarbeit. Land & Water Officer, FAO Land and Water Division

Otoo, M., Lefore, N., Schmitter, P., Barron, J. & Gebregziabher, G. (2018). Business model scenarios and suitability: smallholder solar pump-based irrigation in Ethiopia. Agricultural Water Management – Making a Business Case for Smallholders. Colombo, Sri Lanka: International Water Management Institute (IWMI). 67p. (IWMI Research Report 172). DOI: 10.5337/2018.207

Regassa, E. N., Gebrehawaria, G., Meredith, G. & Charlotte, D. (2013). Small pumps and poor farmers in Sub-Saharan Africa: an assessment of the current extent of use and poverty outreach, *Water International*, 38 (6) 827–839, <http://dx.doi.org/10.1080/02508060.2014.847777>

Phocaidés, A. (2007). *Handbook on pressurized irrigation techniques*. Second Edition. Food and Agriculture Organization of The United Nations Rome, 2007

# MODULE 3

Shallow Groundwater Tube Well Development





# Shallow Groundwater Tube Well Development

## 3.1 Tube Well for Shallow Groundwater in Flood Plains

Tube well technology, which essentially comprises a narrow-dug hole to the depth usually not more than 20m (Abdullahi & Yahya, 2014) for accessing shallow water-bearing formation, is a simple and cost-effective technology to explore shallow groundwater. Surface and groundwater are the major sources of irrigation water. Groundwater is water held within the soil pores, voids and geological formations. Smallholder farmers often struggle to efficiently access groundwater for irrigation (Figure 3.1). Tube well technology uses a small pump to access shallow groundwater where the geological formation presents a shallow aquifer. The use of groundwater for crop production is an ancient practice. However, different factors determine the volume of groundwater available for use. The hydrogeological characteristics of a place describe the aquifer type and productivity.

The type of aquifer affects how deep, easy, and the volume of water that can be accessed. Although the challenge to groundwater use for agriculture or other purposes has always been around, it is critical to ask these questions; how deep is the water, how much water is available or accessible and what is the certainty of available water meeting the intended use? Answers to these questions are not very easy to come by. However, in areas where the water table is almost shallow throughout the year and has a high possibility of water flooding the area in some parts of the year – usually called floodplains – the use of groundwater for agricultural purposes could be very reliable. Annual groundwater recharge is also good in a typical floodplain. In such a landscape with shallow groundwater aquifers, farmers often dig dugouts<sup>1</sup> and open wells

<sup>1</sup> A Dugouts is an open excavation to access shallow groundwater where the water table is shallow (about 4m). Farmers in Ghana and Burkina Faso use buckets or small pumps to lift water from dugouts for irrigation activities.

to access groundwater using buckets or small pumps. These come with a lot of labour and drudgery which limit the extent to which shallow groundwater can be efficiently used for agricultural purposes (Figure 3.1). Tube well technology holds great potential for exploring shallow groundwater in floodplains and sedimentary formations with shallow aquifers. This module presents how to harness shallow groundwater in water-bearing formation within 0 – 20m using the tube well technology.



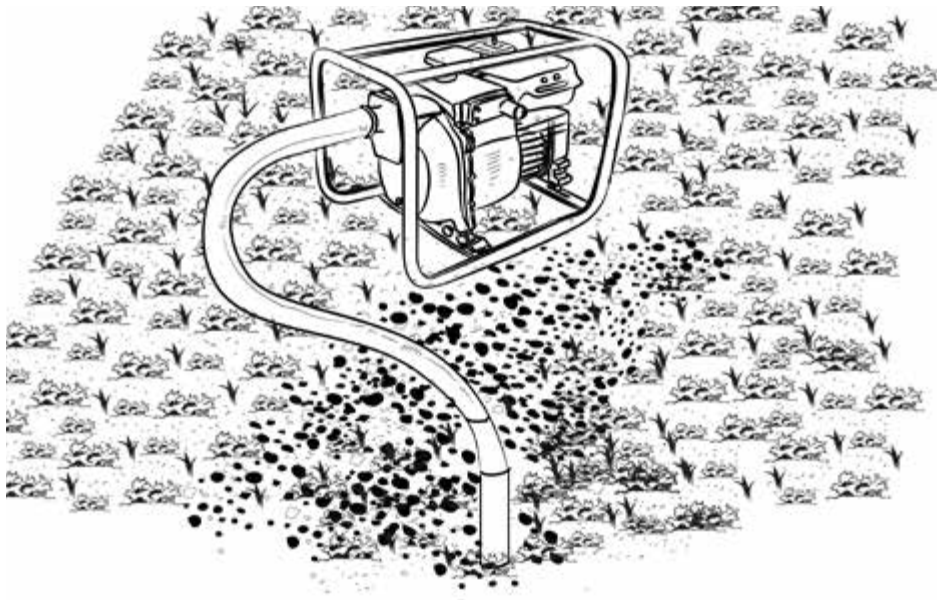

Figure 3.1: (a) Irrigating from shallow groundwater dugout with a bucket in Burkina Faso (b) Tube well installed in the same field

### 3.2 Potential Benefits

The use of shallow groundwater for smallholder agricultural purposes has many advantages for several reasons. In a typical floodplain with a shallow groundwater aquifer, water is available within the area being cropped. Thus, there is a limited need for water conveyance. This is a plus in farmer-led systems where ‘ownership’ and control of water sources are critical to sustainable irrigation practices. Also, unlike the gravity-fed surface irrigation system or river water lifting with pumps with high investment in canals or large structures, shallow groundwater using tube well technology requires minimum water conveyance structures. The water is lifted and easily applied to meet the crop water requirement. Usually, the water can be accessed with low energy since the depth of the water-bearing formation is very shallow, between 0 – 20m. This is the feasible depth for a shallow tube well. Although, groundwater may be available in sufficient quantity at a deeper depth, the deeper the water table, the more energy required for water lifting and such may be beyond

the reach of smallholder farmer-led irrigation actors. Shallow tube well uses a relatively small pump (5 – 8hp) working at low speed thereby consuming less fuel to lift water. The flow rate of 0.5m<sup>3</sup>/hr – 5m<sup>3</sup>/hr is possible depending on the size and yield of the water-bearing aquifer within the location. Recharge of the groundwater system is mainly by infiltration from rainfall. The floodplains are often flooded during the rainy season which increases the recharge of the water-bearing formation. Tube well is also adaptable to the use of solar pumping technology which eliminates the limitations around fuel-powered pumps.

### 3.3 Applications Domains

Tube well technology for shallow groundwater lifting is a simple and effective technology that is applicable in:

1. Floodplains with shallow water table all year round

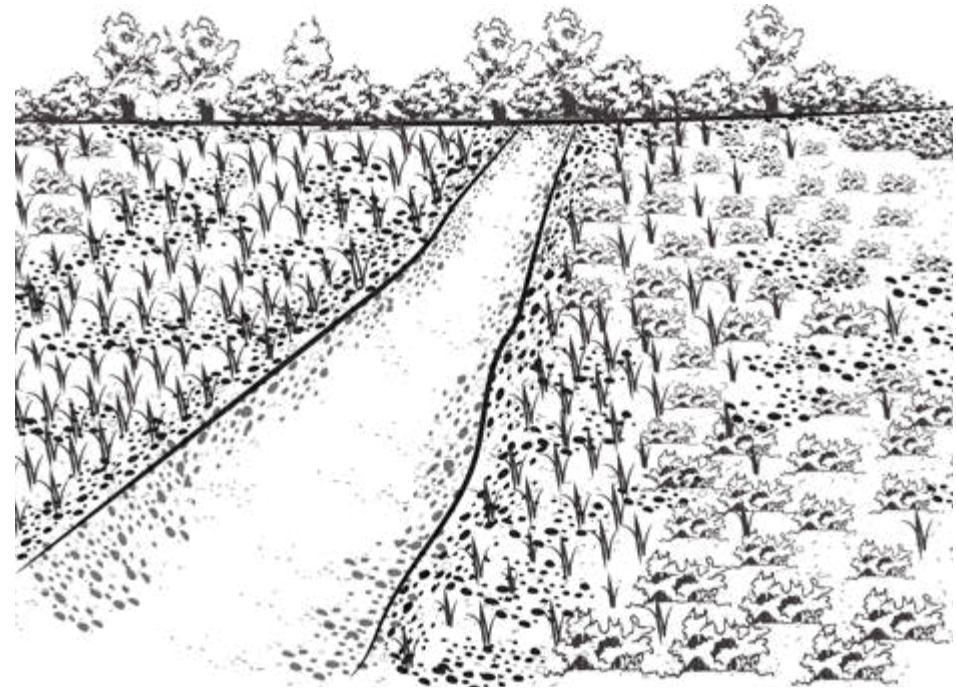

A typical floodplain in Ajingi, Kano, Nigeria

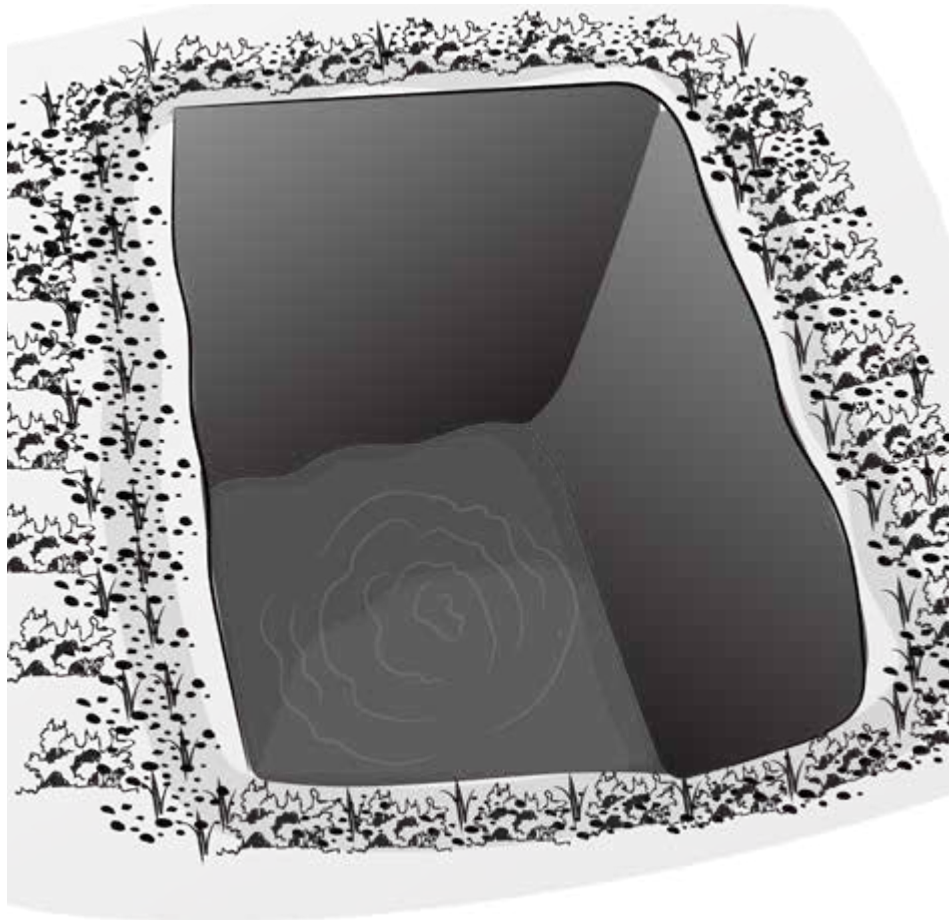

Shallow water table in Bama floodplain, Burkina Faso

*Figure 3.2: A typical floodplain and shallow water table*

2. The sedimentary formations with shallow water table – alluvium, sedimentary formation with an aquifer that may be consolidated consisting of such materials as sand stone, shale or unconsolidated sediment which may contain granular material such as sand, gravel, silt, and clay. Unconsolidated aquifers are easier to dig through than consolidated.



### NOTES

- ✍ Basement (rocky/igneous) formation should not be considered for shallow tube well. The aquifer in this formation are often deeper and materials are rocky and difficult to dig through. It is not appropriate for smallholder tube well.
- ✍ A background review of information on the groundwater table and geologic formation within the area of interest is very important. The web portal (<http://earthwise.bgs.ac.uk/>) provides basic information about the hydrogeologic formation, water table characteristics, the depth to aquifer and possible water yield for most African countries (Figure 3.3). However, this must be reconciled with local information or other available charts/literature.

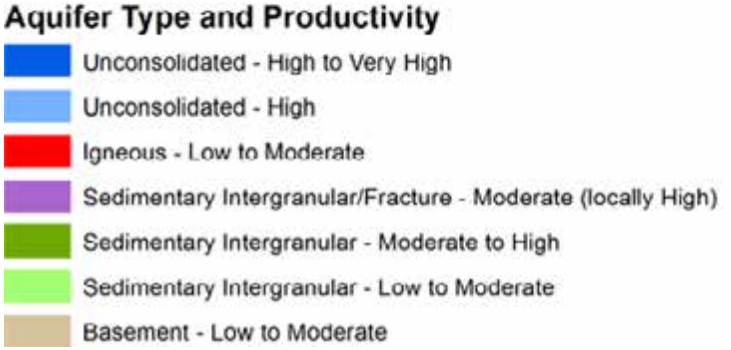
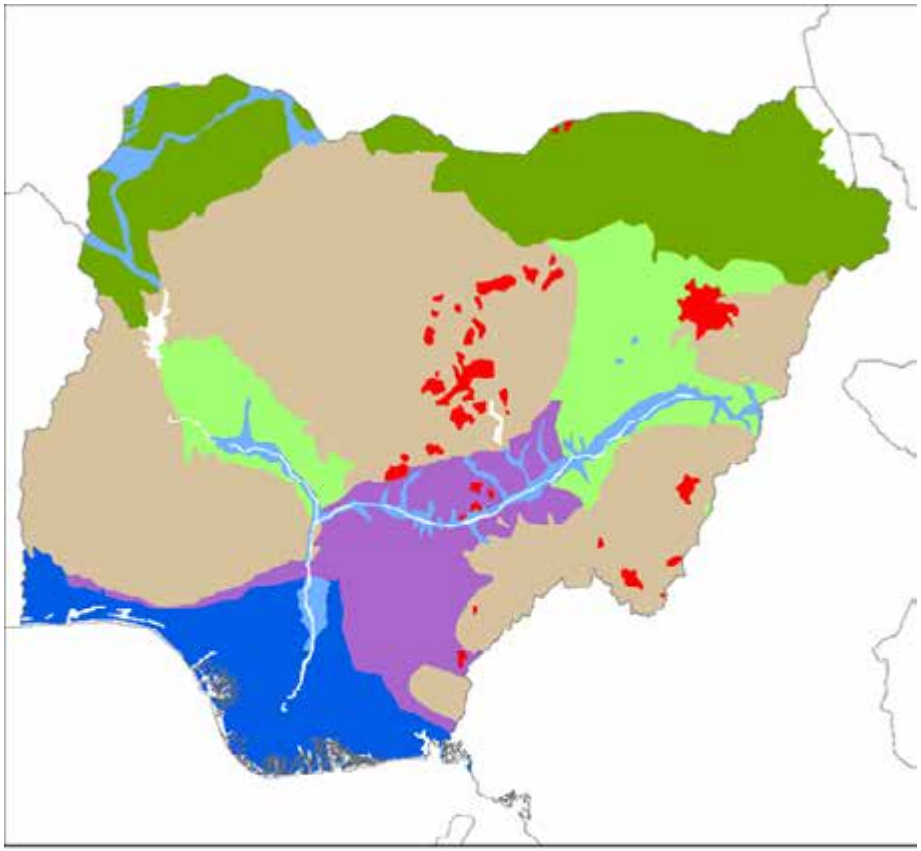
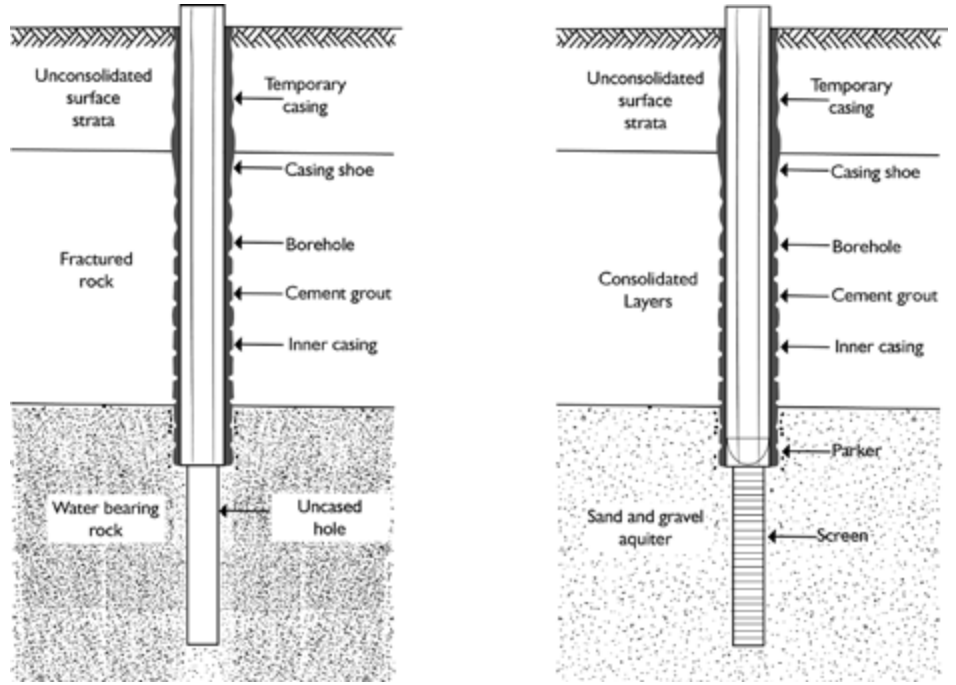

Figure 3.4: Example of a hydrogeological map showing aquifer productivity in Nigeria  
 (Source: [http://earthwise.bgs.ac.uk/index.php/Hydrogeology\\_of\\_Nigeria](http://earthwise.bgs.ac.uk/index.php/Hydrogeology_of_Nigeria))



(Source: <https://www.slideserve.com/xylia/groundwater>)

- ✍ Basic information about local hydrology, characteristics of groundwater which can be extracted from information on open wells within the area, history of the water table, soil profile from open dug well and flood characteristics around the area of interest can also guide in the evaluation of the area.
- ✍ Section 3.7 of this module further highlights how to reasonably evaluate a site for adequacy as a shallow groundwater location.
- ✍ For large scale use of groundwater for irrigation purposes, it is advisable to conduct a proper geophysical survey to be able to access the potential for groundwater within the area of interest.

**3.4 Investment Consideration for Tube Well Acquisition**

The investment in tube well has the potential to transform crop production in places where it is feasible. For instance, floodplains with good shallow aquifers in Burkina Faso, Mali and Nigeria where farmers are restricted to

cultivation during the rainy season alone have been used for off-season irrigated agriculture with the introduction of tube well technology. A tube well can reliably supply irrigation water where the groundwater yield is high and can be in operation for up to 5 years with continuous use. The initial investment to acquire a tube well is low and the technology is not complex. When properly installed in a place with good groundwater potential, a tube well can provide water for between 0.5 to 1.0ha.

The major cost of a tube well is associated with the materials required for the drilling. Although, there are different methods for groundwater well drilling. Two methods are most feasible within the smallholder system and suitable for tube well, in particular – the Hand Auger and Jetting methods.

The choice of either of these methods depends on the formation characteristics, the expected depth to aquifer and local variabilities in terms of availability of materials within the location of interest. Table 3.1 gives a summary of the suitability of each of the methods.

Jetting method is described in this module. The cost of procuring the tools and equipment for installing a tube well using the jetting method described in this manual ranges between \$200 - \$300. The cost includes drilling tools/equipment; pipes, pump, hose and other ancillary materials (see Section 3.6). Apart from the PVC tubes for the drilled well, other materials are tools that can be used for drilling at different locations.

Tube well drilling services are quite possible at a low cost. A service provider may consider an investment in the equipment and tools to enable the provision of drilling and installation services for farmers within a community where the shallow groundwater is feasible. Thus, outside the equipment for tube well drilling, the actual cost/unit of tube well may be less than \$100.

**Table 3.1: Characteristic and suitability of tube well drilling methods in different geological formations**

| Drilling method | Average drilling depth (m) | Suitability in different formations |                              |                     |   |
|-----------------|----------------------------|-------------------------------------|------------------------------|---------------------|---|
|                 |                            | Stiff clay formations Un-weathered  | Soft consolidated formations | Soft weathered rock | Crystalline basement rock, e.g. granite |
| Hand auger      | 25                         | Suitable                            | Not suitable                 | Not suitable        | Not suitable                            |
| Rotary jetting  | 35 - 45                    | Suitable                            | Suitable, less effective     | Not suitable        | Not suitable                            |

Source: Robert (2010)

### 3.5 Drilling Methods

This manual describes the Auger and Jetting methods.

#### 3.5.1 Hand Auger

Hand Auger consists of extendable steel rods, rotated by a handle. Different steel augers (drill bits) can be attached at the end of the drill rods. The augers are rotated into the ground until they are filled, then lifted out of the borehole to be emptied. Specialized augers can be used for different formations and soil materials. Above the water table, the borehole generally stays open without the need for support. Below the water table, a temporary casing may be used to prevent the borehole from collapsing. Drilling continues inside the temporary casing using a bailer until the desired depth or water-bearing formation is reached. The permanent well casing is then installed and the temporary casing must be removed. Augers can be used up to a depth of about 15-25 meters, depending on the geological formation (Robert, 2010).

*Advantage:*

- The technique is easy to use with cheap equipment.

*Disadvantage:*

- It is labour intensive and it may be difficult to remove the temporary casing.
- It is difficult to use in sandy or clay profiles.

*Suitable application:*

- Practically suitable in sedimentary formation especially within the floodplain landscapes but not in basement complex formation

**3.5.2 Jetting**

Jetting is based on water circulation and water pressure pumped down the drilling pipes. The large volume of pressurized water has an erosive effect at the bottom of the jetting pipe. The ‘slurry’ (water and cuttings) is transported up between the drill pipe and the borehole wall. A motor pump is used to achieve an adequate pressurized flow. The drill pipe may simply have an open end, or a drill bit can be added and partial or full rotation of the drill pipe can be used to achieve further cutting. Thickeners (additives) can be added to the water to prevent hole collapse and reduce the loss of working water (drill fluid). Jetting (with rotation) can drill up to depths of 35- 45 meters (Robert, 2010).

*Advantage:*

- Drilling is achieved very quickly in the sand and very soft geological formations.
- Drilling is much faster than the auger method.

*Disadvantage:*

- Requires much quantity of water for jetting.
- The level of the water table is not known during drilling.

- It takes some experience to know when to stop drilling when the water-bearing aquifer is reached.
- Its application is limited to sand and thin layers of soft clay or loosely consolidated materials.



*Suitable application:*



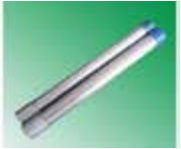

- Practically suitable in sedimentary formation especially within the floodplain landscapes but not in basement complex formation

This module concentrates on Jetting method because of its effectiveness, simplicity and affordability within the investment capacity of the smallholder systems. It is not too technical as the steps involved are explained in this module. The materials required for the installation and operation of tube well using jetting techniques are common and available within the community.

**3.6 Tools and Equipment Required for Drilling Tube Well Using Jetting Method**

The material required for digging of a unit of tube well to the depth of 6 – 10m (maximum) are briefly presented below:

|   | Jetting tools               | Description  | Illustration  |
|---|-----------------------------|--|---|
| 1 | Drilling heads/drill bits   | This is the pipe end that is used for cutting soil materials as jetting or digging continue.   |   |
| 2 | Drilling pipes (galvanized) | Drilling pipes GI – 3m length x 4nos. The pipe with a connecting socket and a good end thread. |  |
| 3 | Water hose                  | Adequate hose of the right diameter for pump discharge to connect with the jetting pipe.       |  |

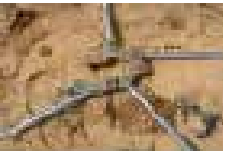
|    | Jetting tools  | Description   | Illustration   |
|----|--|---|--|
| 4  | 2 pumps (5hp) one each for water lifting and jetting | One pump each to lift water from the water source and the second pump to create pressure for jetting                      |  |
| 5  | Jetting swivel (head)                                | The swivel ensures that the jetting pipe is rotated without the intake pipe rotating along during the drilling operation. |  |
| 6  | Strainer/foot valve                                  | Strainer with foot valve for suction hose of the pump.  |  |
| 7  | Hack saw   | Hack saw with a blade for cutting pipes and making slots for screens.   |  |
| 8  | 24" Pipe Wrench (2nos)                               | Pipe wrench for tightening and loosening of pipes.  |  |
| 9  | Jetting pipe clamp (optional)                        | The special clamp enables a firm grip on the jetting pipe and also serves as a handle for turning during operation.       |  |
| 10 | Labour   | At least 3-4 persons will work during the drilling operation. Drilling time is a function of the formation.               |  |

### 3.7 Steps in Tube Well-Digging Using Jetting Technique

5 major steps serve as a guide to constructing a tube well using Jetting technique.

#### Step 1: Explorative survey and Wellpoint selection: (See section 3.3)

- Access the floodplain – consult survey records, publications, other sources including <http://earthwise.bgs.ac.uk/> for the hydrogeological characteristic of the intended area.
- Evaluate the water table characteristics all year round, ask questions from farmers and the community within the area.
- Use dugouts, open wells, pits to assess the soil profile characteristics within the floodplain.
- Assess the sand, gravel, clay, silt, shale etc. characteristics to reasonable depth (0-5m).
- Ask local well-diggers about soil characteristics and depth to the water table.
- Decide on the feasibility of shallow groundwater using tube well technology in the area based on the above survey details.

#### Step 2: Water Source, Pumps positioning and Drilling Pipe:

- Secure a source of water and place pump with hose laid to the new well point – identified for drilling the tube well.
- Construct a mud pit 1m x1mx1m with a smaller pit linked to it.
- Attach drilling pipe and jetting swivel.
- Connect the pipe to the pump discharge hose to maintain good water pressure for jetting.
- Ensure all connections are strongly secured.



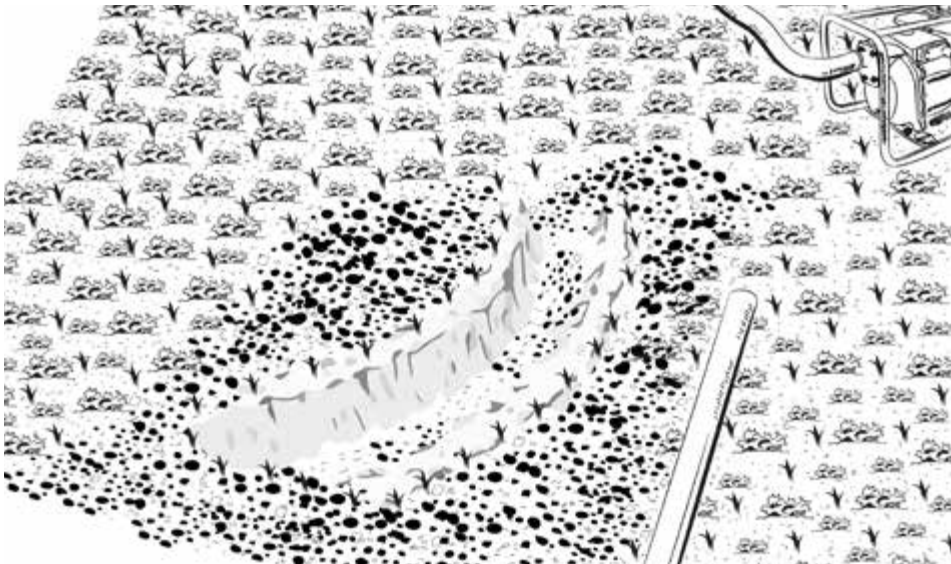
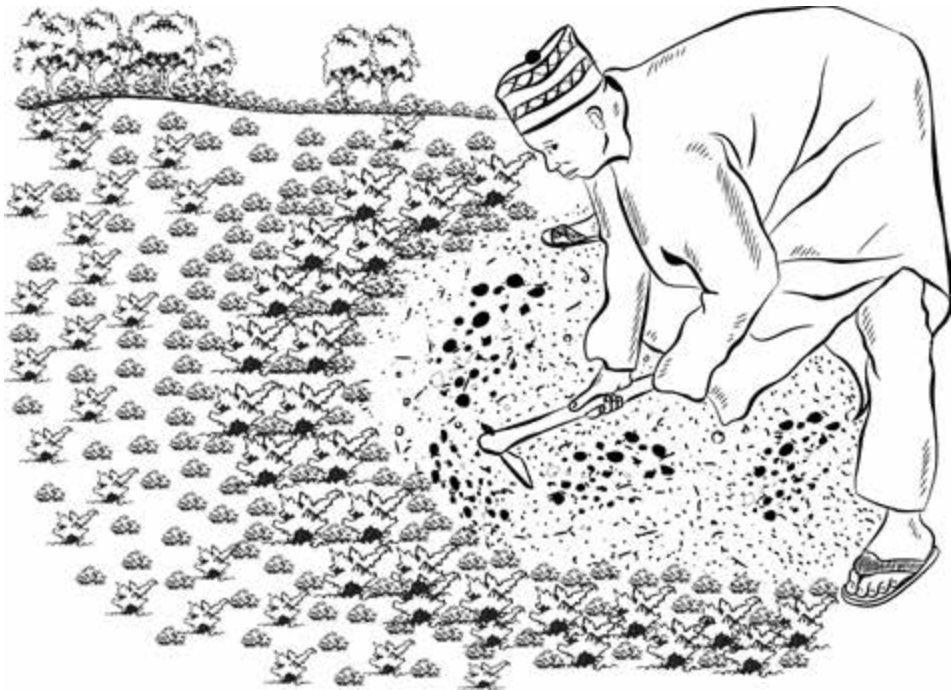

Step 2: Locate the well point and construct mud pit



Connect pump for jetting with drilling pipe, lift water into the mud pit and ensure tight connections

### Step 3: Prepare tube pipe

- 2 or 3 lengths of PVC pipe with end thread.
- Make slots within the 50-100cm end of the pipe.
- Cap the pipe end.

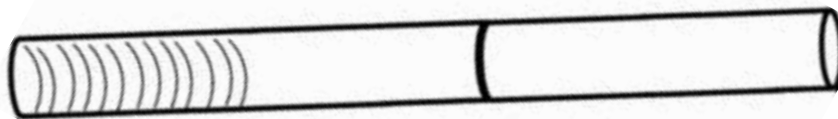
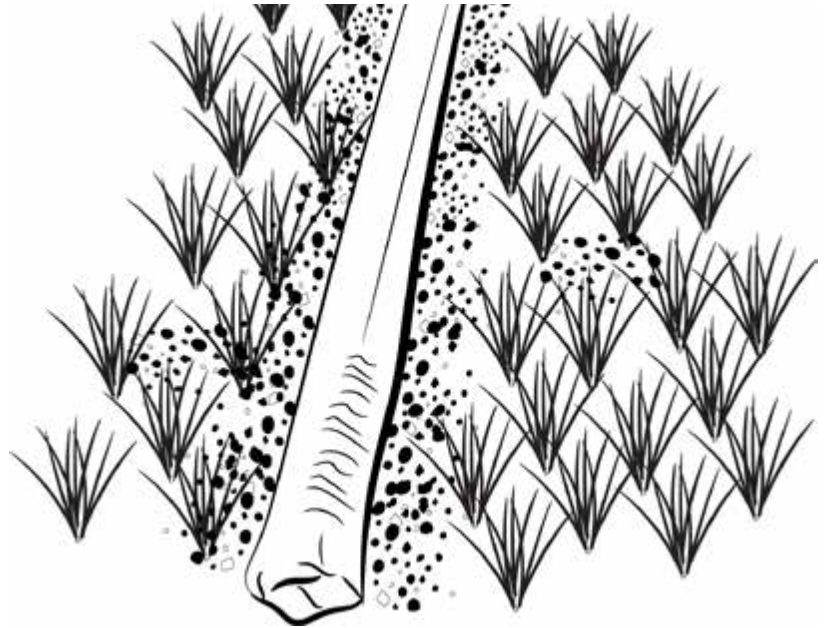

Step 3: Tube pipe – PVC with slots as screens

### Step 4: Drilling to Required Depth

- Start the pump and pumping with good water pressure.
- Continuously raise, lower and rotate slightly the galvanized drilling pipe to maintain a round hole.
- Continue jetting with pumped water pressure until you observe good water and fine sands from the well.
- Hint on when to stop digging: observe fine sand, remove the digging pipe and attempt pumping with a small pump.





Step 4: Drilling tube well by jetting from water pump pressure

**Step 5: Casing Installation and Test Pumping**

- Lower the tube pipe with the slots/screens into the hole to the drilled depth.
- Connect your pump and pump water into the new well to clean up the tube well.
- Add gravel as a pack to the wall of the installed tube.
- Connect your pump to the tube and conduct a pumping test. Pump within a known time (e.g. 60 seconds) into a container with a known volume. Calculate the volume of water discharged from the pump over 60 seconds.
- Do a backfill of the tube after the gravel pack has been poured around the screen.

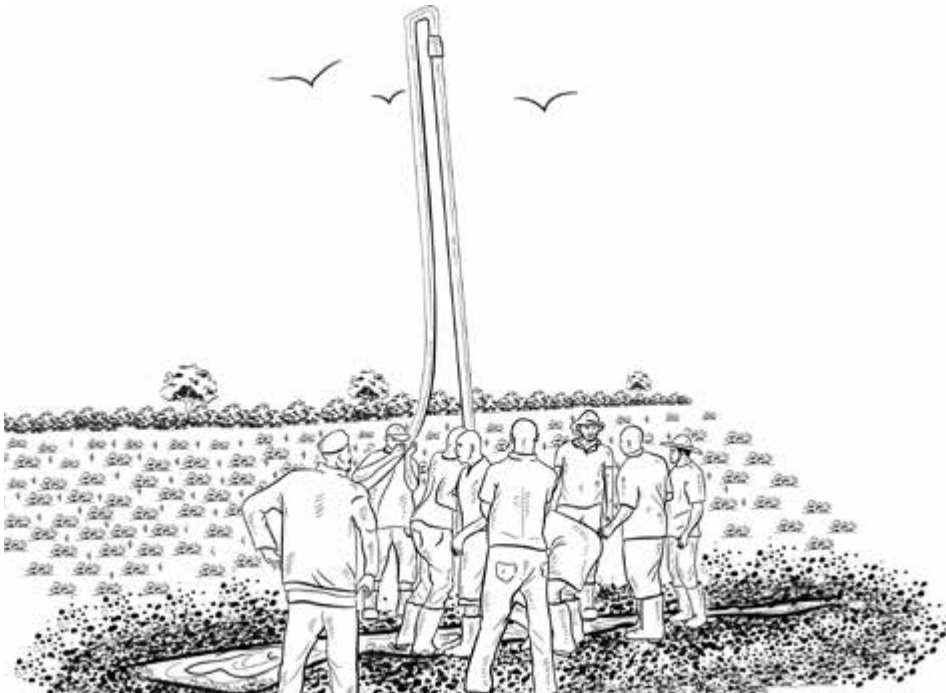

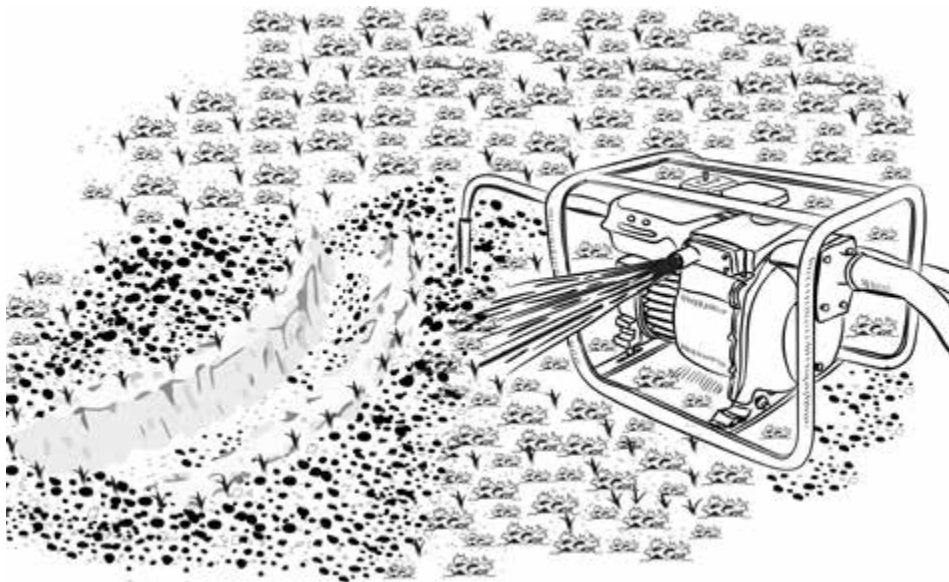

Step 5: Casing, pumping and pump testing

### 3.8 Operation and Maintenance

#### 3.8.1 Tube Well Maintenance

A tube well should be protected in the following ways

1. Ensure a perfect connection of the tube to the pump to avoid leaks that may hinder pump suction. If a leak exists, priming and pumping may be very challenging.
2. Always cap the tube well when not in operation.
3. Ensure that the well point is properly marked for identification after the flood has receded since tube well is often in place which may be flooded during the rainy season.

#### 3.8.2 Pump Maintenance

Before operation

- Check the fuel and engine oil levels.
- Top up fuel as appropriate.
- Check any part that may require tightening. Avoid any loose parts.
- Ensure that the coupling or connecting devices are intact.

During operation

- Avoid the formation of an air bubble within the suction pipe which happens when the pump suction end comes out of the water.
- Ensure fuel is adequate throughout the operation. Stop the pump to top up fuel.

After operation

- Always keep the pump dry.
- No water should be left in the pumping chamber after operation, especially if the pump is not in permanent connection and being used often.
- Ensure you keep all the pump accessories safe e.g. coupling devices, hose, strainers, suction lines etc.

## Link to Installation Videos

Shallow Tube well construction with Jetting method

wowjeff01: <https://www.youtube.com/watch?v=hzcix8WFLYI>. (Accessed December 5, 2020)

## Disclaimer

The mentioning of any equipment brand, illustrated or explained in this module is for the purpose of training. The IWMI does not promote any brand of equipment and will not take responsibility for the choice of any brand.

## Acknowledgement

All the illustrations used in this manual have been appropriately cited. Any omission is hereby highly regretted.

All the photographs used in this manual are courtesy of IWMI and Dr. Adebayo Oke.

The wowjeff01 YouTube Channel is acknowledged for the video on Shallow Tube well Construction using Jetting Method.

## Bibliography

Abdullahi, A. & Yahya, M. K. (2014). Use of Tube well technology for sustainable water supply in dryland areas of Kano State. Proceedings of the 1st International Conference of Drylands, Bayero University Kano, Nigeria.

Robert Vuik (2010). Manual Drilling – Jetting: Technical Training Handbook on Affordable Manual Well Drilling. The Practica African Groundwater Hydrogeology. [http://earthwise.bgs.ac.uk/index.php/Africa\\_Groundwater\\_Atlas\\_Home](http://earthwise.bgs.ac.uk/index.php/Africa_Groundwater_Atlas_Home)

# MODULE 4

Runoff Water Harvesting: Farm Pond  
and Embankment Dam Development



# Runoff Water Harvesting: Farm Pond and Embankment Dam Development

## 4.1 Runoff Water Harvesting

Runoff generated in agricultural farms in places with either high or low annual rainfall is often not utilized. Crop production still suffers a varying degree of drought which can be more profound in places with lower rainfall. Runoff can be harvested for supplementary irrigation to mitigate drought in such an environment. Runoff water harvesting is an ex-situ water conservation technology where runoff water is stored to be used beyond the point where it was collected. Water harvesting ponds are artificial water storage structures to hold runoff water during the rainy season while the water could be used for different purposes subsequently. Runoff can be harvested either for short term use or for a longer period. The period and scale of use will inform both the type of structure to be constructed and the volume of water to be stored. Runoff water storage structures can be either small scale (such as depressions, dug-outs, water pan, farm pond) or large scale (embankment dams and reservoirs). The scale intended determines the storage and other ancillary structures needed for the reliability, adequacy and sustainability of the system. This module provides a basic guide on the construction of a farm pond.



Figure 4.1: A Lined Farm

## 4.2 Potential Benefits

Harvested water from storage structures like farm ponds can be used for irrigation during the dry season or as supplementary irrigation to mitigate drought even in the wet season. They can also be used for supplying the water needs of animals in smallholder systems. The abundance of runoff water that is often not captured within watersheds can be put to productive uses. The use of water harvesting structures such as farm ponds and embankment dams can also improve groundwater aquifer replenishment. It is a feasible way of using rainwater and runoff within a watershed.

## 4.3 Application Domains

Runoff water harvesting technology and farm ponds are applicable across different landforms. It is most feasible where there is a mild slope (2 – 5%). Runoff water harvesting usually takes the form of

- **Farm Pond:** It is made from the diversion of runoff into a dug or excavated area resulting in a pool or a pond. This farm pond involves more construction costs and, therefore, are generally recommended



when embankment type ponds are not economically feasible for construction.

- **Embankment Dam:** The embankment dam is made from the construction of a retention/embankment wall or a small dam across a small river along a depression to create a pond. The structure can be made from rock boulders, sandbags or concrete to retain flowing water.

As a rule of thumb, streams and rivers that cannot be waded through at the peak flow or with a very wide cross-section may be too large and require more engineering processes to establish a safe and secure embankment structure. Such rivers may be considered for a temporary clay sack embankment to retain water during the dry season, the period of low flow.

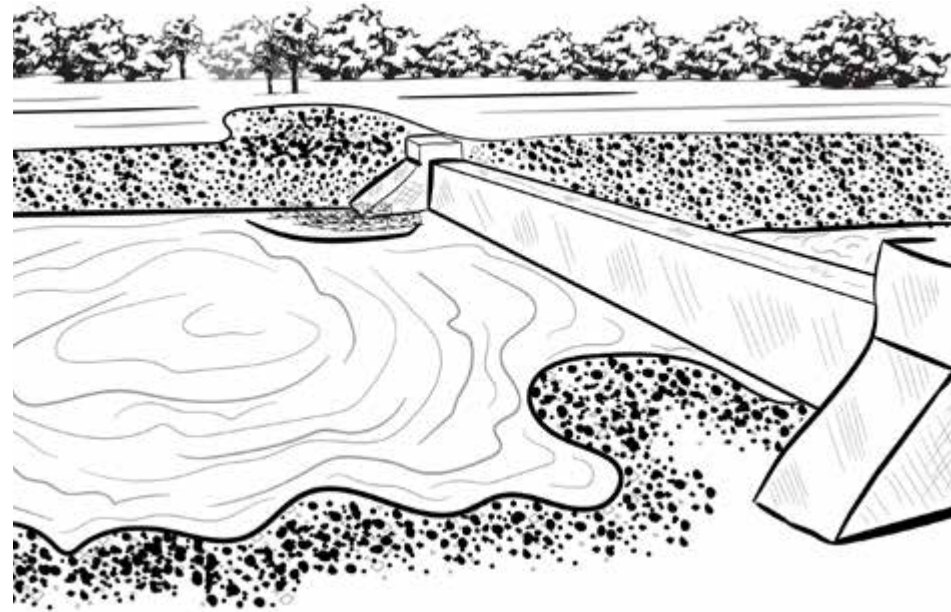

Small concrete dam

Figure 4.2: Examples of runoff water harvesting structures

### 4.3.1 Preliminary Considerations

A preliminary field evaluation is needed to determine what type of water storage structure will be most adaptable to the field where the water will be needed for agricultural purposes.

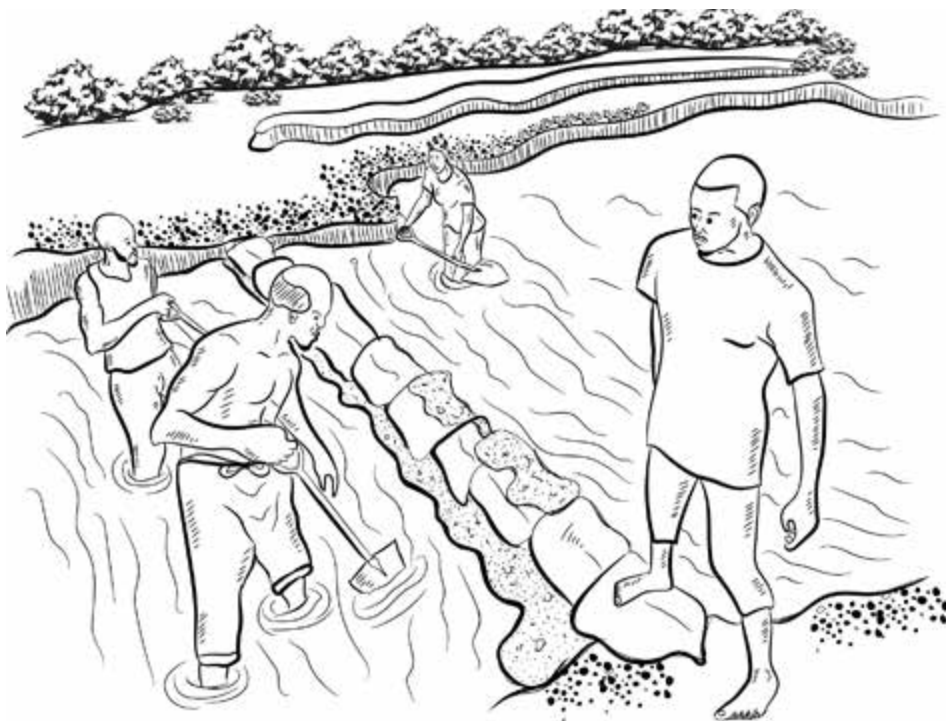

Clay sack embankment dam

| Farm Pond  | Embankment dam  |
|--|---|
| <ul style="list-style-type: none"> <li>▪ Identify a watercourse, runoff path or small stream in the farm area.</li> <li>▪ Identify the major land-use type and soil texture within the catchment of runoff generation.</li> <li>▪ Identify a potential site with a slope between 1 - 5%. Areas with Clay Soil is most preferred.</li> <li>▪ You need the monthly average rainfall depth in your area.</li> <li>▪ At least last 5-10 years observation on rainfall and runoff pattern. It is very important to estimate available runoff in your area.</li> </ul> | <ul style="list-style-type: none"> <li>▪ Small river/stream</li> <li>▪ River depth less than 2m</li> <li>▪ The width of the river cross-section should not be more than 5m</li> <li>▪ A valley or depression is required to create a storage pool at the embankment</li> <li>▪ Observe a 'V' or shape cross-section</li> <li>▪ A stable cross-section (clayey or rock outcrop)</li> <li>▪ Evaluate the distance from the farm – where the water will be used</li> </ul> |

#### 4.4 Investment Cost Considerations

The construction of either an excavated pond for runoff storage or an embankment such as a check dam, rock dam or sandbag across a small stream/river to create a water storage pool comes at a cost. Usually, the type of structure that is feasible in a location determines largely the associated costs. For instance, materials to be used for the structure, the volume of storage, the area to be cleared and the engineering challenges within the location (which are often peculiar to a site) to ensure a stable construction are critical variables that determine the overall construction cost. A key component of the construction of a farm pond is the excavation of the storage area. This often accounts for a significant part of the construction cost whether manual effort or mechanical excavator is used. If the pond

is to be lined with polythene nylon – to disallow percolation of stored water – the construction cost increases. Similarly, if the embankment dam is made of concrete or stone boulders, the cost will be significantly more than a temporary embankment constructed from clay sacks. Therefore, costs per unit storage capacity will vary from different places and with the structure to be constructed. However, a smallholder may not have to start with a large structure that demands huge financial costs.

#### 4.5 Steps to The Construction

This module considers basic steps in the construction of (1) Farm Pond and (2) Embankment or Check Dam.

##### 4.5.1 Construction of Farm Pond

###### *Materials*

Depending on the type of structure, method of construction and size of the structure, the following may be required for the construction of a farm pond:

- Measuring tape
- Spades and digger (for manual excavation)
- Mechanical excavator
- Stone boulders, gravels, sand and cement
- Labour – masons and labour for digging and excavation

###### Step 1

- Identify a watercourse, runoff path or small stream in the farm area. The runoff path from the area around the farm can be channelled into a storage structure.
- Identify the major land-use type and soil texture within the catchment of runoff generation
- Identify the potential site. The slope should be between 1 - 5%.
- Consider that the location is stable.

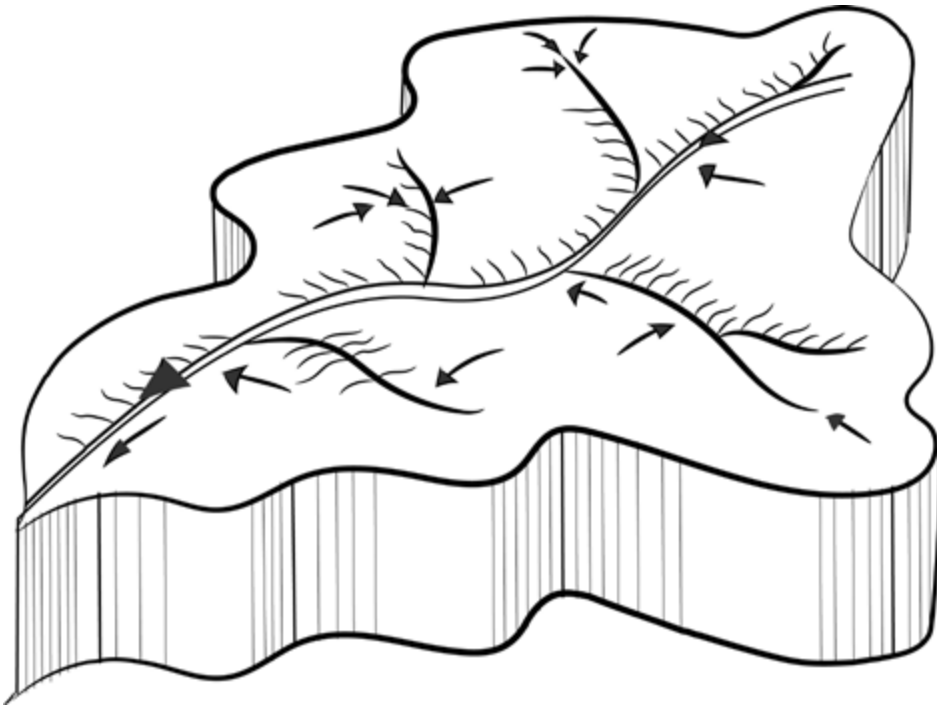

Figure 4.3: Sketch of catchment runoff generation model

**Estimation of Runoff from a Catchment**

$R = C_R \times P$  .....1

Runoff coefficient is obtained from Table 1 based on the major land use and predominant soil texture.

- R (mm) = Potential Monthly Available Runoff water
- $C_R$  = Runoff coefficient depending on the land use and predominant soil type in the watershed (Table 4.1)
- P (mm) = Monthly rainfall
- Total Annual Runoff is the sum of Potential Monthly Runoff, R.

The total harvested runoff within a specific area is computed using equation 2.

$Q (m^3) = Total Annual Runoff (m) \times Catchment Area (m^2)$  .....2

Harvested runoff is the available volume of water from the immediate catchment draining to the pond. The catchment area where runoff is harvested.

**Step 2: Estimate average peak annual runoff and potentially available runoff**

- Use equation 1 to obtain average annual runoff based on average monthly rainfall depth.
- Use equation 2 to compute potential harvested runoff from the immediate catchment area. If the catchment increases, the runoff increases and this estimation will increase the size of the storage structure to be constructed.

**Table 4.1: Runoff Coefficient for Different Land Use and Land Cover type, texture classes at 0.5 - 5% Slope**

| Land Use       | Sand | Loamy Sand | Sandy Loam | Loam | Silty Loam | Silt | Sandy Clay Loam | Clay Loam | Silty Clay Loam | Sandy Clay | Silty Clay | Clay |
|----------------|------|------------|------------|------|------------|------|-----------------|-----------|-----------------|------------|------------|------|
| Forest         | 0.07 | 0.11       | 0.14       | 0.17 | 0.21       | 0.24 | 0.27            | 0.31      | 0.34            | 0.37       | 0.41       | 0.44 |
| Grassland      | 0.17 | 0.21       | 0.24       | 0.27 | 0.31       | 0.34 | 0.37            | 0.41      | 0.44            | 0.47       | 0.51       | 0.54 |
| Croplands      | 0.27 | 0.31       | 0.34       | 0.37 | 0.41       | 0.44 | 0.47            | 0.51      | 0.54            | 0.57       | 0.61       | 0.64 |
| Barelands      | 0.37 | 0.41       | 0.44       | 0.47 | 0.51       | 0.54 | 0.57            | 0.61      | 0.64            | 0.67       | 0.71       | 0.74 |
| Built-up areas | 0.59 | 0.61       | 0.62       | 0.64 | 0.66       | 0.67 | 0.69            | 0.71      | 0.72            | 0.74       | 0.76       | 0.77 |

Source: Karamage et al. (2019)

**Step 3: Determine the pond size**

- The farm pond can take any shape – rectangular, pyramidal, spherical or circular depending on the firmness and stability of soil in the site or the capacity to undertake the type of construction.
- To avoid sliding of the sidewall soil, the pyramidal shape may be preferred.
- The pyramidal shape can be made by marking the top and bottom as rectangular shapes (Figure 4.4).

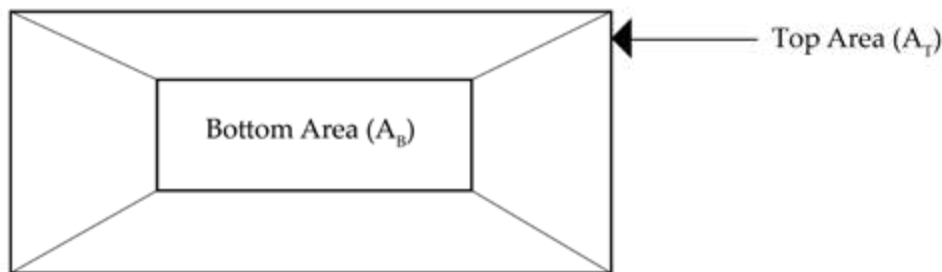

Figure 4.4: Plan view of the excavated farm pond

**The volume of Earth Removed = Volume of pond = Storage capacity of your pond**

$$\text{Volume (m}^3\text{)} = [A_T A_B + A_T \times A_B] \dots 3$$

$$A_T = \text{Top Area (m}^2\text{)} = L_T \times B_T$$

$$A_B = \text{Bottom Area (m}^2\text{)} = L_B \times B_B$$

H = Depth of Pond (m)

$L_T, B_T$  and  $L_B \times B_B$  are Length and Breadth of Top and Bottom areas respectively

Example:

If H = 4m Assuming a rectangular shape for the 2 areas

$$A_T: L = 10\text{m}; B = 4\text{m}; A_T = 10 \times 4 = 40\text{m}^2$$

$$A_B: L = 8\text{m}; B = 3\text{m}; A_B = 8 \times 3 = 24\text{m}^2$$

$$\begin{aligned} \text{Volume} &= (4/3) * (40+24+ \sqrt{(40*24)}) \\ &= 72\text{m}^3 = 72,000 \text{ liters of water} \end{aligned}$$

**Step 4: Excavation of pond and lining of the pond**

- With the dimensions determined:
- Pond excavation can be manually or mechanically done (using heavy equipment).
- Existing (natural or artificial depressions) can be used as a farm pond.
- Ensure the watercourse is directed into the pond and an overflow channel/spillway is created.
- The overflow should be 0.2H deep and 0.2 – 0.3 top width wide (Figure 4.5).

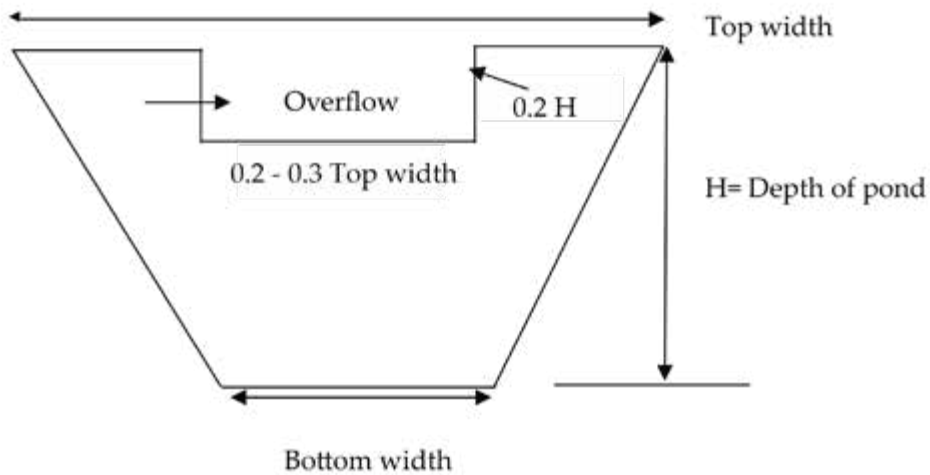

Figure 4.5: Side view of a typical farm pond with an overflow spillway

- The overflow section can be stabilized with Rip-Rap stones work to eliminate the possibility of erosion.
- The lining of the pond removes the loss of water by percolation. This attracts an extra cost, but it is highly recommended if the pond is not too large!

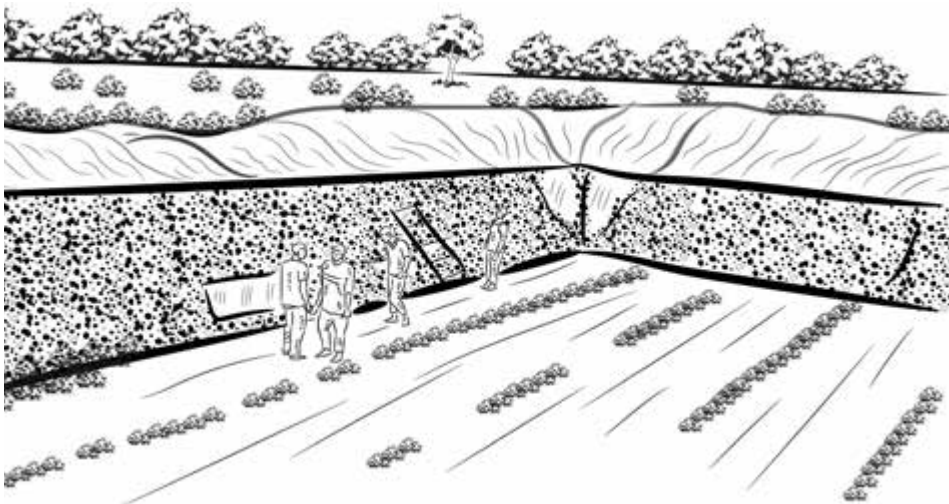

Figure 4.4: Farm pond constructed by farmers

### 4.5.2 Embankment Dam/Sand Bag Construction

The embankment/sandbag dam is constructed across a stream or a small river. An embankment dam may take different shapes and dimensions – depending on the volume of water to be stored, the physical features of the location and available materials and funds for the construction. The embankment may be a permanent structure when constructed from stone boulders and concrete. However, with a simple clay sack, a temporary dam can be made.

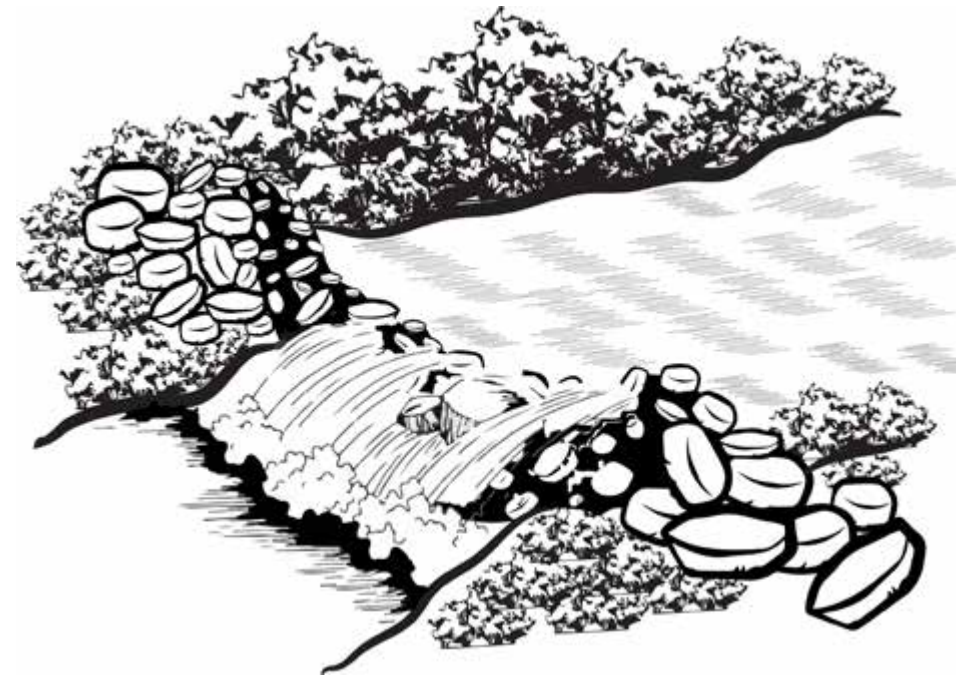

Figure 4.5: An embankment dam constructed from stone boulders

#### Materials

As it is with a farm pond structure, materials required depend on the method of construction, type and size of the structure, the engineering challenges at the site and the level of stability intended. These factors vary across locations. However, the following may be required for the construction embankment dam:

- Measuring tape
- Spades and digger for foundation excavation
- Stone boulders, gravel, sand and cement – for the construction of concrete embankment
- Iron rod for reinforcement (optional) – for the foundation and concrete structure where a high degree of stability and permanent structure is desired.
- Labour – masons and labour for digging and excavation.
- Clayey materials and sacks – where simple clay sack embankment is the focus.

### Step 1: Location selection

- Check the stream/river to locate a good cross-section that is stable on the opposite side.
- It is more preferred if the river bed at the considered location is a rock outcrop (Figure 4.8).
- The stream with a width between 2 – 5m is appropriate for a micro embankment/ dam. The challenges and engineering demand for the construction of an embankment on a bigger river are beyond the scope of this guide. The cost may also not be affordable for a smallholder farmer.
- When the maximum river depth is more than 2m, the runoff or river discharge at the peak of the rainy season may be too much for a small structure to retain.

Therefore, when river/stream width is greater than 5m and the observed peak river flow depth is greater than 2m, extra assistance may be required to avoid excessive flow which may lead to failure of the structure.

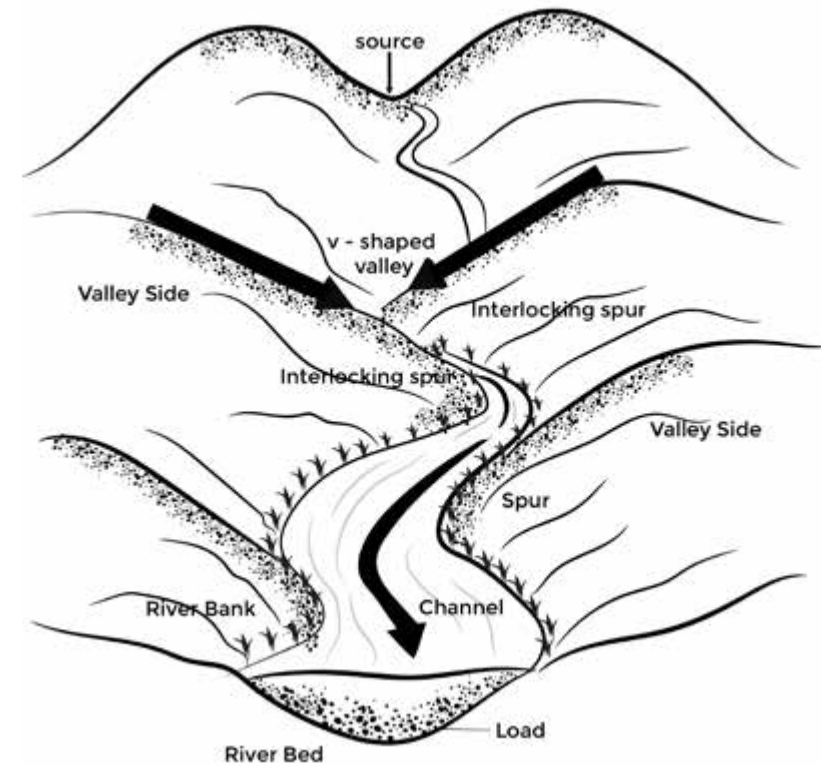

Figure 4.6: Sketch of stream course and landforms  
(Source: [http://www.geography.learnontheinternet.co.uk/topics/river\\_upper\\_course.html](http://www.geography.learnontheinternet.co.uk/topics/river_upper_course.html))

### Step 2: Design plan and construction materials

- Consider the flow - the river/stream.
- The construction material available e.g. clay, stone boulders or gravel stones. If it is possible, take advantage of locally available materials to reduce the cost of construction.
- Construction of the embankment with a clay bag will be cheaper than stone boulders which will be set with mortar.
- Concrete embankment with the possibility of reinforcement steel structure from the foundation may be more expensive.

### Step 3: Construct the embankment with the assistance of labours or masons

- Fill the clay bag with clay materials and lay the bags across the river stream.
- The use of a clay bag is a temporary embankment measure.
- If a stone boulder or concrete embankment is chosen, a foundation between 0.5 – 1.0m may be needed to ensure the stability of the structure.
- The height of the embankment dam should not exceed half of the maximum river/stream depth (**0.5 x River depth**), especially if the structure is to serve more than one season.
- If the entire river course is blocked to retain water, the spread of water or flooding may arise during the rainy season.



Construction of stone boulder embankment dam across a stream

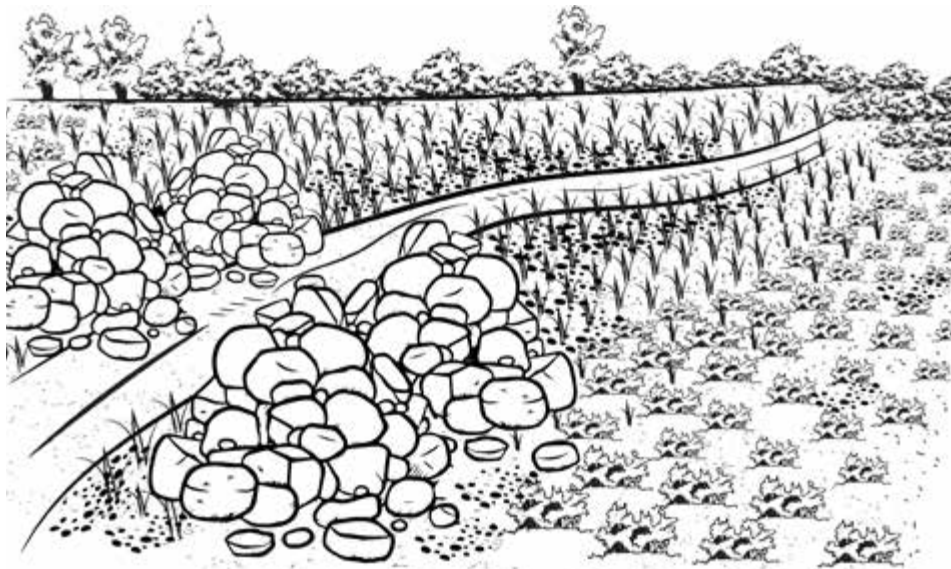

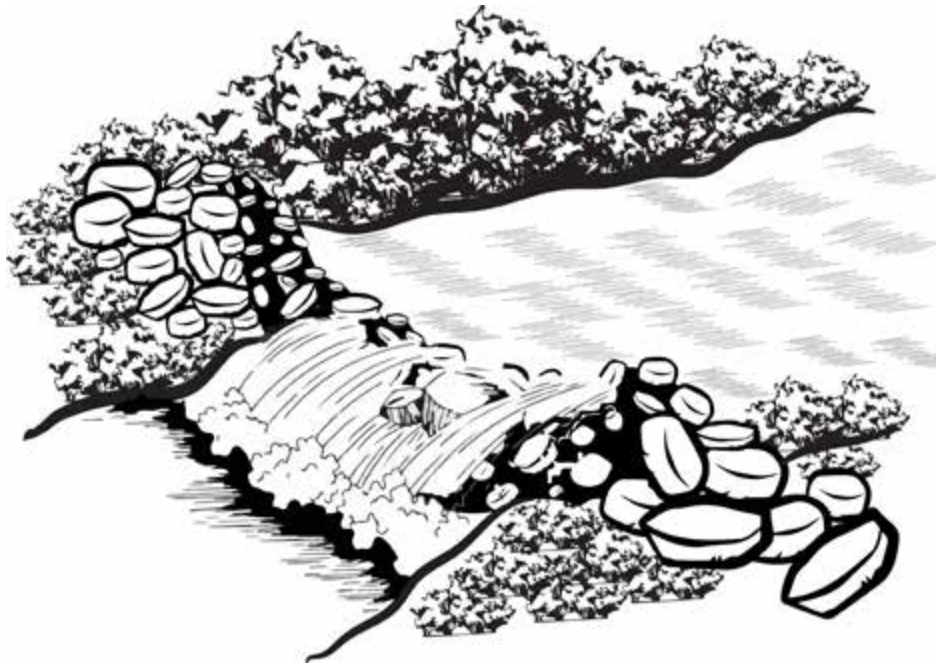

Completed embankment dam in place

#### 4.6 Operation and Maintenance

- Constant monitoring of the banks, embankment dam base and the structure is important, especially in the case of rock boulders and concrete embankment dams to locate any leak over time.
- Clay embankment is a temporary dam and may have to be repaired or rebuilt every season.
- The possibility of siltation may be high which, over time in farm ponds and embankment dams, may reduce the storage capacity. Removal of silt and sediment may be required after a period depending on the sediment yield within the catchment.
- Farm pond and embankment dam storage area may be prone to evaporation in drylands; therefore, it is good to plan the water use to take maximum advantage of stored water before the peak of the dry season. For instance, ensure early planting of crops in the off-season

so that the plant water need is met by the available stored water. Evaporation may reduce the retained water significantly which may affect available water for crop production.

- If the farm pond is used for animal watering, ensure that the animals do not pollute the pond and match into the structure. This can be done by lifting water for the animals at the bank of the pond.



## Link to Installation Videos

Construction of farm pond. Utmost Precision: <https://www.youtube.com/watch?v=X-EUiXqChN0> (Accessed December 5, 2020)

## Disclaimer

The mentioning of any equipment brand, illustrated or explained in this module is for the purpose of training. The IWMI does not promote any brand of equipment and will not take responsibility for the choice of any brand.

## Acknowledgement

The farm pond video is from The Smart Water for Agriculture project under the Netherlands development organization. Utmost Precision YouTube channel is acknowledged.

All the illustrations used in this manual have been appropriately cited. Any omission is hereby highly regretted.

All the photographs used in this manual are courtesy of IWMI and Dr. Adebayo Oke.

## Bibliography

Karamage, F., Liu, Y., Fan, X., Francis Justine, M., Wu, G., Liu, Y., Zhou, H. & Wang, R. (2019). Spatial relationship between precipitation and runoff in Africa, *Hydrol. Earth Syst. Sci. Discuss.* <https://doi.org/10.5194/hess-2018-424>, 2018.

Awulachew, S. B., Lemperiere, P. & Tulu, T. (2009). Training manual on agricultural water management. IWMI (International Water Management Institute), Addis Ababa, Ethiopia, ILRI (International Livestock Research Institute), Nairobi, Kenya and Adama University, Adama, Ethiopia.

# MODULE 5

Closed Pipe Conveyance System



## Closed Pipe Conveyance System

### 5.1 Closed Pipe Conveyance Systems for Smallholder Irrigation

Conveyance of water from the source, either river water or groundwater wells, is a key component of an irrigation system. Water sources may not necessarily be very close to the field even in the case of groundwater extraction; some form of conveyance is always required to make water available for irrigation in the field. Often, with the aid of a pipe or gravity-fed canals, water is conveyed to the farm for different types of irrigation practices. Open canals network or field channels conveyance is very common but usually, results in significant loss of water to evaporation and percolation along the channels. Construction of such channels also involves huge earth excavation. The concrete or lining required to remove water losses increases the cost of construction. In farmer-led irrigation, the use of a High-Density Polyethylene (HDPE) or Polyvinyl Chloride (PVC) closed pipe system can be used to effectively convey water for irrigation purposes. Farm water supply and irrigation network can equally be made from wrought iron, aluminium and asbestos pipes, although, HDPE and PVC are easier to work with, and have a relatively lower cost per unit length. It reduces water losses, improves the distribution of irrigation water and makes water application in the field much easier. The HDPE or PVC pipe system which includes connection of appropriate sizes of plastic pipes as a network of main lines, sub-main, and laterals with hydrants may come at an extra cost compared with open easily-constructed earth field channels for irrigation. However, it reduces the volume of water loss to evaporation, percolation and it improves field water conveyance efficiency. It also enables the use of irrigation equipment with better water application efficiency such as sprinklers and drip systems. Although, there are other pipe materials such as Aluminum and Galvanized pipes HDPE and PVC pipes are preferred because it is readily available and the cost is relatively low. This manual will dwell on HDPE/PVC pipes for smallholder irrigation practices.

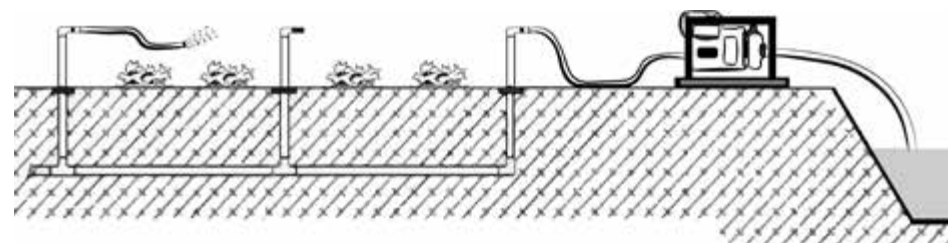

Figure 5.1: Buried Pipe Network system (Source: FAO, 2014)

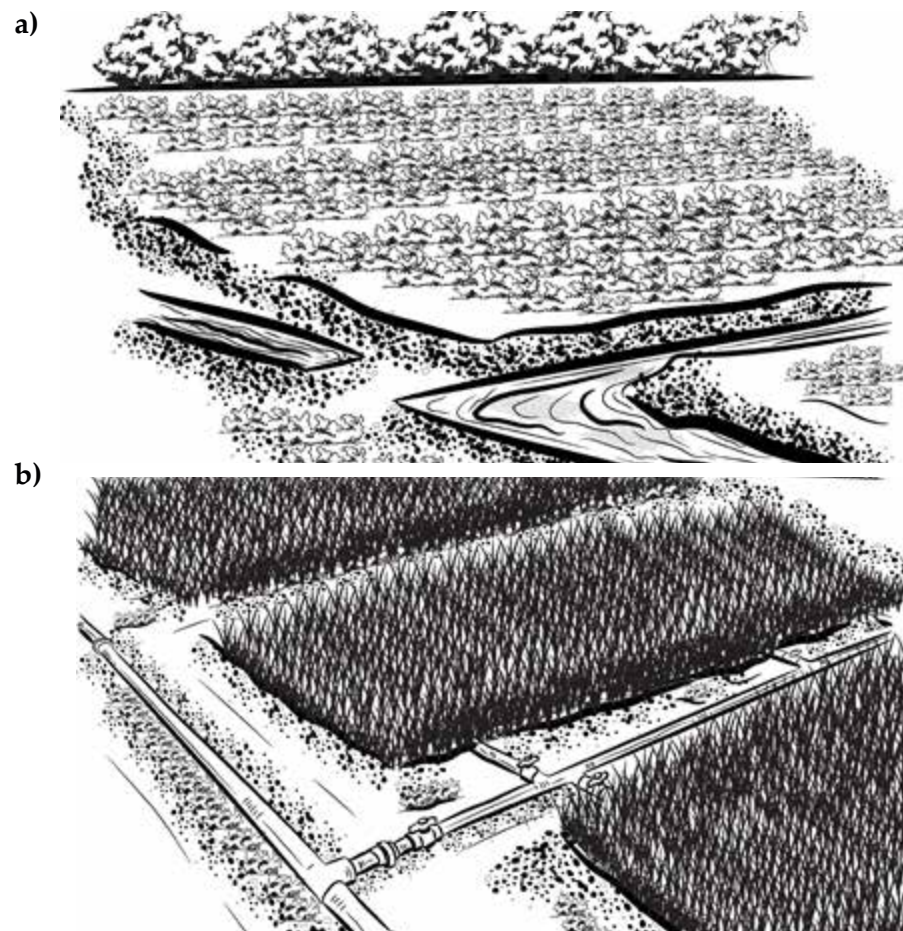

Figure 5.2: (a) Field channels for water conveyance (b) closed-pipe conveyance system

## 5.2 Potential Benefits

The use of an HDPE/PVC pipe system can efficiently improve crop water productivity by reducing the losses incurred during the conveyance of water from sources to the point of irrigation. It has been observed that an open gravity-fed irrigation system is about 40% efficient in terms of water conveyance efficiency. In farmer-led systems, pumping water from rivers or groundwater aquifers into earthen field canals is not an efficient practice. Also, it may not be feasible to create field water conveyance channels in some fields that are available for temporary cultivation or within an urban agricultural environment. Even where earthen field channels are feasible, more fuel pumping and irrigation time will be required per unit irrigated area as compared with when water is conveyed in pipelines. A pipe conveyance system also allows for efficient movement of water from a source far from parcels of land to be irrigated. It enables the use of a single water source – rivers, ponds or wells to irrigate multiple land areas. Piped delivery systems can also justify investment in wells and water pumps since it becomes possible to operate for longer hours thereby irrigating more land areas. An efficient water conveyance system saves labour, fuel and time required for irrigation and increases the area to be irrigated can be significantly reduced. The HDPE/PVC pipes system can be installed either as a buried network or on the field surface such that it can be removed after a season and re-installed in accordance with the field configuration or layout for different cropping systems. In a smallholder farming system, it can be used in combination with a small motorized pump, a treadle pump or gravity from an elevated water reservoir. The HDPE/PVC system when properly maintained may be used for many years.

## 5.3 Application Domains

The HDPE/PVC conveyance system is adequate for low- and high-pressure irrigation practice, depending on the specifics of the irrigation methods, the terrain, and the pressure. It is adaptable to the irrigation of different crops e.g., vegetable production, rice, wheat and can be easily combined with different irrigation systems such as surface irrigation (basin, furrow), sprinkler (different types/capacities) and drip irrigation

practices. Within a smallholder system, pumping is usually within the pressure of 2 – 4 bar, especially when sprinkler heads are in operation. Other smallholder irrigation methods require less pressure. Therefore, with motorized pumps and other water lifting devices, HDPE/PVC can be reliably used for most irrigation applications. The system is adaptable to most production terrains including places with high slopes and can be combined with field water conservation techniques like check basin and terracing thereby reducing field erosion.

## 5.4 Investment Costs Considerations

The cost required for the installation of an HDPE/PVC pipe system may vary with the terrain, land shapes, distances and the specifics of crop field layouts. However, as an average, the investment required for low-pressure pipe systems with the pump unit is still high at around US\$1 000 to 1 500/ha (FAO, 2014). The cost may be less in some countries where there is local production capacity or duty-free policy on the importation of the pipes and fittings for agricultural materials. Investment, however, can easily be recovered as water pumping, allocation and easy operation ensure more accurate and efficient water application, resulting in water savings, larger irrigated areas and higher yields per unit area in comparison with the rainfed system. The PVC and HDPE have an operating life of up to 50 years, especially if buried and less if subjected to sunlight and are moved around. However, with good maintenance, PVC and HDPE can last long (Sustainable Solution Corporation, 2017) and in good service.

Other benefits of the pipe conveyance system in smallholder irrigation include:

- It can help deliver water to multiple land parcels from a single water source (especially beneficial where land-fragmentation is a big issue);
- It reduces the time taken to irrigate unit area vis-à-vis open channel distribution; and
- A piped distribution system can help maximize pump operating factor (hours of operation per season) which can better justify the initial capital investment.

## 5.5 Design and Installation Guide













### 5.5.1 Installation Considerations











Installing an HDPE/PVC conveyance system requires skills in combining different HDPE/PVC pipes and fittings in a way that will serve as a conveyance system for irrigation. The following must be noted:

1. The HDPE/PVC pipes and fittings come with pressure ratings. For smallholder conveyance systems, HDPE/PVC pipes and fittings with a pressure rating of 2 – 4 bar should be selected. Usually, the pressure classes are stated as PN (Nominal Pressure). Thus, PN2.5 means maximum pressure for the pipe is 2.5bar while PN16 means maximum pressure that the particular pipe can withstand is 16 bar. PN of 6 is most appropriate for irrigation pumping. A sprinkler system may require 2-4 bar maximum while drip irrigation requires much lower pressure (1 – 2 bar).
2. Irrigation companies often can guide their clients in the pressure class required for the irrigation type.
3. The sizes of HDPE/PVC pipes and fittings depend on the field layouts. The size of the mainline will be based on the pump outlet diameter. The sub-main and laterals depend on the network of the system designed (See section 4.4.2 and 4.4.3).
4. It is important to patiently go through the planning phase to be able to decide what quantity and type of materials are required.
5. Where necessary, you may need some guidance from dealers, plumber/fitters or irrigation consultants. Do not shy away from making such consultations to avoid buying what you may not need.

Table 5.1 gives a detailed description of different materials that are needed in the designs and assembling of HDPE or PVC pipe conveyance network.

**Table 5.1: Descriptions of PVC materials used in the construction of irrigation water conveyance network**

| Item                    | Description   | Use  | PVC   | HDPE  |
|-------------------------|---|--|---|---|
| HDPE Pipes or PVC Pipes | HDPE and PVC Pipes are in different diameters (e.g. 1", 1 3/4", 2", 2 1/4", 3" or 4") | Pipes are the main element for fluid flow. For irrigation pumping, low to medium pressure range is required (PN class 2 or 4 will allow the pressure of 2 or 4 bar respectively)<br><i>Sanitary pipes are not appropriate for irrigation water pumping</i> |    |    |
|                         |   |  | Comes in the length of 6m or 9m   | Comes in a roll up to 100m (depending on length require)                              |
| Coupling/ Connector     | For connecting pipes of the same sizes together                                       | If their sizes differ, the fitting is known as a reducing coupling, reducer.   |    |    |
| Elbows                  | Either 45o or 90o of different pipe sizes   | Usually used between two lengths of pipe (or tubing) to allow a change of direction. Elbows could be normal elbow (same end sizes), reducer elbow (connecting different sizes with thread or non-thread inside)  |    |    |
| Tee                     | A Tee is used to combine or divide the fluid flow                                     | Tees can connect pipes of different diameters or change the direction of a pipe run, or both. They can be used with bushes to reduce sizes and connect pipes of different sizes  |    |    |
| Adapter                 |   | It comes with either male and female threaded ends. It may be needed when connecting pipes of different materials e.g. PVC with HDPE or PVC with Galvanized  |  |  |
| Union                   | A union also connects two pipes   | It is used to connect pipes and allows future disconnection of the pipes for maintenance. It consists of three parts: a nut, a female end and a male end. It is a component that enables the system to be disengaged as a mobile unit.                     |  |  |

| Item                                 | Description  | Use   | PVC   | HDPE  |
|--------------------------------------|--|---|---|---|
| Saddle clamp                         | Saddle clamps are used in HDPE connections to create inlet links or connecting point | The saddle is best used to link a lateral line to the submain or mainline. It comes in different sizes with types that can connect 2 pipe sizes e.g., 2" – ¾"   |    | <br>Valve installation on Saddle |
| Reducing bushing                     | Bush is installed to reduce pipe diameter  | Where necessary bushes are used with fittings such as Tees or elbows to reduce pipe size being connected  |    | <br>HDPE have reducer connectors |
| Valves                               | Valves stop (or regulate) the flow of liquids  | There are different types and brands. Gate and ball valves of appropriate pipe sizes are mostly used in simple irrigation conveyance. With appropriate fittings, they are adaptable to both PVC and HDPE pipes. |    |   |
| Cap                                  | End cover  | Needed at the pipe end of a pipeline, to cap hydrants or groundwater well   |    |                                  |
| PVC Gum                              | Hard fast setting PVC glue   | It is used in joining pipes and fittings where necessary. Sometimes in a very low-pressure connection, the connection may be firm enough without glue   |   | <i>HDPE Pipes do not need glue. The fittings are mostly threaded. This is one big advantage of HDPE over PVC</i>    |
| Water meter (optional)               | A water meter is used to monitor the volume of water pumped into the pipe network    | For a smallholder, this may be optional. However, where irrigation water is paid for, especially with a higher level of equipment sophistication, the water meter is essential.                                 |  |   |
| Pressure-regulating valve (optional) | For controlling and maintaining pressure requirements in an irrigation system        | In a large-scale drip system, the pressure regulating valve is not optional.  |  |   |



**Notes:**

- i. Pipe diameters come either in inches (imperial) or millimetre (metric). Be consistent in the choice of the unit to avoid confusion and fitting problems.
- ii. Cost per unit length of PVC and HDPE pipes may vary according to local production capacity or policy on importation duties. In some countries, irrigation equipment and materials attract little or no import tariff. This type of policy impacts positively on equipment costs.
- iii. Although HDPE pipes are relatively of lower cost per unit length as against PVC, however, HDPE fittings are generally more expensive than PVC fittings.
- iv. Either PVC or HDPE can be buried or lay on the land surface. Buried pipe systems in large fields (more than 1 hectare) may require a little more technical considerations beyond the scope of this manual.
- v. Ensure to contact competent technicians, pipe companies, irrigation engineers or equipment suppliers to guide in the details as much as you may require. Technical consultations will be required when the field is more than 1 hectare to choose the right pipe sizes, determine total dynamic head or system pressure, estimate discharge, plan the layout among others and decide on different components for efficient operation.

**5.5.2 Considerations for Layouts of HDPE/PVC Conveyance**

There are endless possibilities in the design or use of HDPE/PVC irrigation water conveyance lines. The options chosen depend on these factors. These major considerations are critical to the investment size, field operations, economics of operation and sustainability of the project.

- *The possible layout of the field i.e., the dimension and field shape:* Agricultural fields do not always have regular shapes i.e., rectangular, circular etc. However, the shape of the field, the length, width and how these dimensions are situated relative to the water source will determine the placement of the mainline, sub mainlines and laterals. It will also inform how the field may be partitioned into blocks.
- *The size of the field to be irrigated at an irrigation event and the number of partitions /blocks in the field:* There are many reasons why it may be advantageous to partition the field into blocks, especially if the field is

more than what the available equipment can technically irrigate at the same time. Irrigating one hectare at a go requires more water, energy, labour and ancillary equipment (irrespective of irrigation methods) than irrigating one-third of a hectare. Field partitioning may enable the same investment on one-third of a hectare to be effectively used to irrigate one hectare by rotation. Partitioning may also enable planting different crops within the field. The numbers and sizes (areas) of the blocks are crucial to the type and configuration of the pipe conveyance network, especially intake hydrants to be designed to meet the water supply in the block.

- *The irrigation equipment to be used or connected at the hydrant/connecting point:* Irrigation devices to be connected at the hydrant should be considered when deciding on the pipe size – diameter and connecting device on the hydrant. For instance, what type of lateral, hose (flexible or reel), or sprinkler size? A rain hose tube requires a 1-inch diameter hydrant spaced at 2m while a giant or gun sprinkler may require a 2-inch diameter hydrant point with spacing up to 60m or more (depending on the wetted perimeter of the gun sprinkler).
- *The volume of water and operating pressure that is expected at the hydrant or for the irrigation methods:* Surface irrigation can be achieved by allowing water to flow from a hydrant directly into the field. However, other irrigation methods require a certain level of pressure to operate efficiently. The pressure and discharge requirement of irrigation application device to be connected to a pipe hydrant point should be considered in the planning and decision on the size and configuration of the pipe layout network (See section 5.5.3).
- *The pump capacity (the total head and discharge/pump outlet diameter):* As a rule of thumb, the bigger the field to be equipped for irrigation with pipe conveyance, the more discharge and pumping capacity required for efficient operation. However, the field may be partitioned for the same pump to be used to supply water to different field blocks. The Total Head and Discharge Capacity determine the pump capacity. These two elements are key to the pipe size/ diameter to be installed in the layout (See Module 2).
- *The land tenure (how many years is available for the use of the field):* The

years available for the use of land – rent or lease – should be considered when investing in irrigation infrastructure. If the land rent is short, there is a limit to the investment on such land area. For instance, you may not be able to bury pipes or undertake capital intensive water source development.

In the following section, basic possible designs are presented. The layout can be buried or laid on the land surface depending on some of the factors earlier mentioned in Section 5.5.1 and 5.5.2

### 5.5.3 Example of Field Conveyance Set-Up

#### 1. Mainline – Sub-main – Lateral - Hydrant

The mainline is the main part of the conveyance system. It has the largest diameter depending on the quantity of water to be taken to the field which also depends on the area to be irrigated. The layout can be **Mainline** (4")<sup>1</sup> → **Sub main** (3") → **Lateral** (2") → **Hydrant** (2" or 1"). This type of configuration may be appropriate for a big field (field more than 1 hectare). The spacing between the sub-mains, laterals and hydrants depends on the field configuration as well as the equipment to be used.

Other possible layouts can be

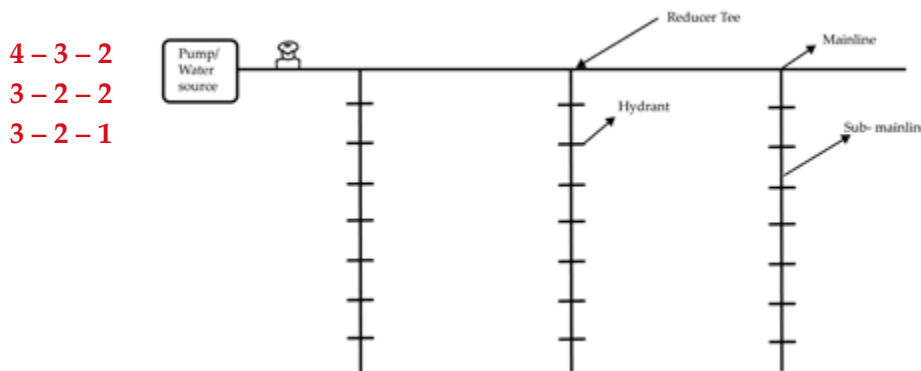

#### The hydrant

The hydrant is the outlet that pipe or flexible hose can be connected to deliver irrigation water to the field. Each hydrant is equipped with a ball

<sup>1</sup> 4" – 4 inches

or gate valve with an appropriate coupling device. A hydrant is a place where sprinklers, drip lines or spray tubes can be connected. The flow in a particular hydrant is controlled with the valve. The valves size could be of the same size as the lateral line or with the aid of reducing bushes, the lateral line can be of different pipe size.

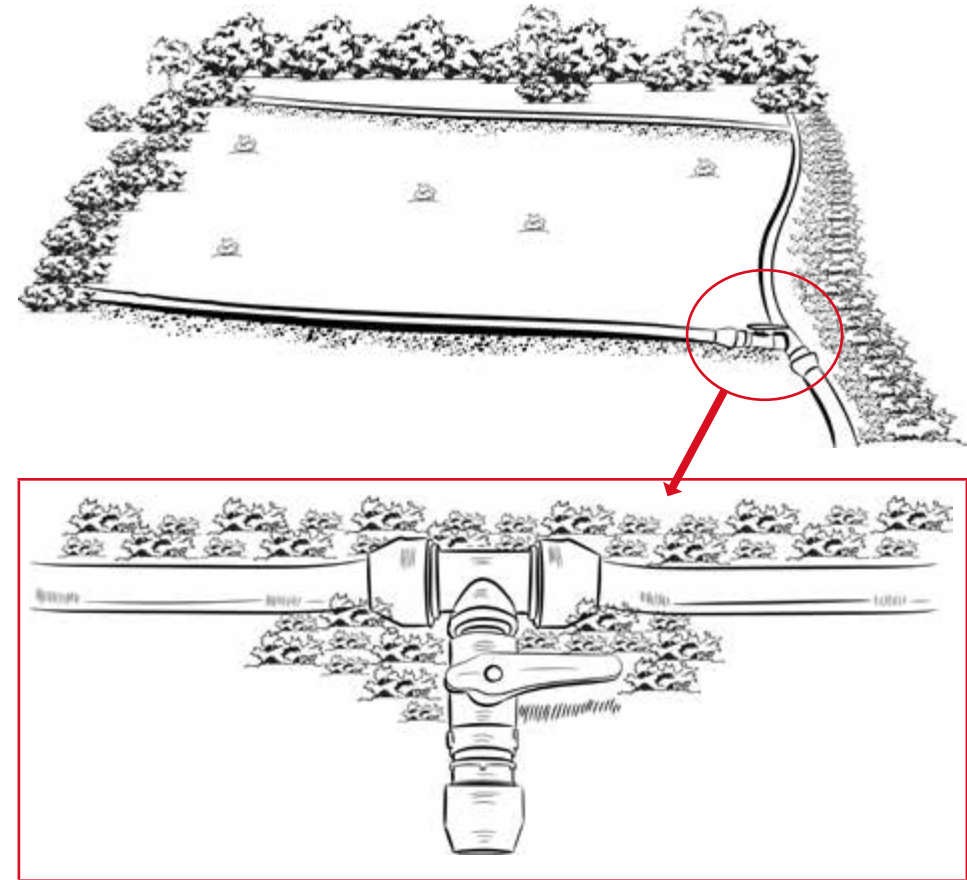

#### 2. Mainline → Lateral → Hydrant (Double-end hydrant)

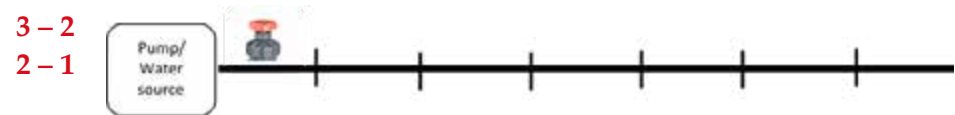

### 3. Single line → Single-end Hydrant



It is also possible to lay a network of PVC/HDPE pipes to deliver water at the field basin/bed level. For example, in the production of wheat and rice, the pipe network can be arranged with a combination of unions, valves, elbows and similar fittings to deliver water to check basins.

## 5.6 Operation and Maintenance

- Groundwater, rivers, streams and opened storage structures – e.g., ponds and lakes – are the sources of water in irrigation systems.
- Ensure that the water source to be pumped in the pipe system is clean, not turbid or full of sediments.
- Use the PVC or HDPE with the right pressure rating as earlier described.
- The connections must be firm not to allow leakages. This is important always.
- Before starting the pumps, ensure that appropriate hydrant valves are opened to deliver water along the lines you wish to irrigate. Never start operating your pumping system without opening the discharge outlet, it will build up pressure and burst the system.
- If the pipe system is not buried, avoid driving over the installations. The PVC or HDPE pipe cannot bear the weight of vehicles or tractors.
- Endeavour to pack all your pipes and fittings from the field after the season to avoid losing them to thieves, bush fires and tractors running over them.
- Keeping your material safe at all times will ensure that it serves for long years.

## Disclaimer

The mentioning of any equipment brand, illustrated or explained in this module is for the purpose of training. The IWMI does not promote any brand of equipment and will not take responsibility for the choice of any brand.

## Acknowledgement

All the illustrations used in this manual have been appropriately cited. Any omission is hereby highly regretted.

All the photographs used in this manual are courtesy of IWMI.

## Bibliography

Food and Agricultural Organization (2014): Irrigation Techniques for Small-scale Farmers: Key Practices for DRR Implementers. FAO Rome.

Phocaides, A. (2007). Handbook on Pressurized Irrigation Techniques. Second Edition. Food And Agriculture Organization Of The United Nations Rome, 2007

Sustainable Solutions Corporation (2017). Life Cycle Assessment of Water and Sewer Pipe and Comparative sustainability analysis of pipe materials.

# MODULE 6

Surface Irrigation: Basin, Border  
Strip and Furrow Systems



# Surface Irrigation: Basin, Border Strip and Furrow Systems

## 6.1 Surface Irrigation

Surface irrigation is the most common irrigation method among smallholder farmers. In its simplest form, water is released to flow within a bounded area of a crop field by gravity. The bounded area may be wide as in basin or border irrigation and may be narrow as in the case of furrow irrigation. Surface irrigation takes advantage of field slope to distribute water from high to low elevated areas of the field. However, very high slopes may significantly reduce the efficiency of the irrigation system and cause soil erosion, especially in sandy soils. Topography, slope, soil type, crop type and water source are some of the factors that must be considered in selecting the type of surface irrigation to be implemented in a field. This module provides a brief on the basin, check basin, furrow and border strip irrigation.

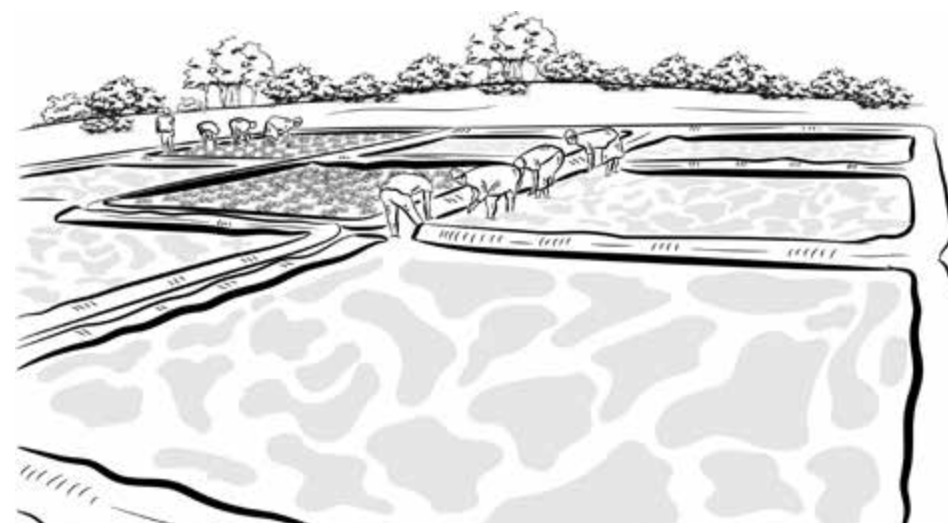
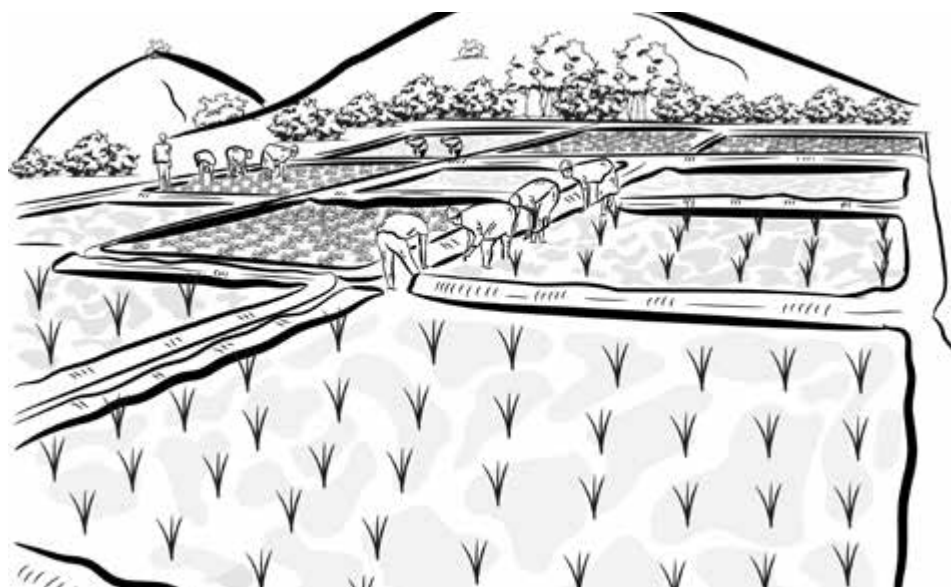

Basin irrigation

## 6.2 Basin Irrigation

### 6.2.1 Application Domains

Basins can be adapted to suit most crops, soil or farming practices. Slopes up to 3% can be irrigated by basins. On steeper slopes, basin irrigation can be implemented. However, it must be with good conservation practices such as terracing, low flow non-erosive stream size and smaller basin sizes. Typically, terrace width varies from 1.5 m for 4% land slopes to 150 m for 0.1% land slopes.

### 6.2.2 Crops

Basin irrigation is very suitable for paddy rice. Other crops which are suited for basin irrigation include field crops such as maize, wheat, and beans; pastures; grasses; trees, e.g. citrus, banana; and various vegetables. Basin irrigation is generally not suitable for crops that cannot stand in wet or waterlogged conditions for 24 hours. It is not suitable for crops that require loose, well-drained soils, especially root and tuber crops such as potatoes, cassava, beet and carrots.

### 6.2.3 Topography

Basin irrigation is practised where land is relatively flat. The flatter the land surface, the easier it is to construct basins. Some levelling may be required on uneven lands to ensure uniform water distribution. Basins can also be constructed on terraced slopes.

### 6.2.4 Soils

Basin irrigation can be used in a wide variety of soil textures. However, fine-textured clay-loams are preferred. Clay-loams have moderate infiltration and therefore do not get waterlogged easily. Coarse sands are not recommended for basin irrigation due to their high infiltration rate.

### 6.2.5 Stream Size

Basin irrigation utilizes large stream sizes as the entire irrigated area is flooded. Water is applied from a field canal through siphons, spiles or by breaching the dyke to create an inlet. Generally, for the same stream size and irrigation depth, basins should be smaller on light soils than on heavy soils.

## 6.3 Investment Costs and Feasibility

The construction of structures for surface irrigation – basins, check basins or furrow – are done after the land preparation including land levelling. These structures require labour for their construction and the cost depends on the prevailing costs within the farm environment. For instance, the cost of making check basins is within the range of 150 - 200usd/ha. The technicalities involved in the construction of structures for surface irrigation are usually within the technical and financial feasibility of smallholder farmers.

## 6.4 Design and Installation

### 6.4.1 Basin Design

Basin layout refers to the shape and size of basins as well as earth bunds. Factors such as land topography, slope, soil type, crop to be grown and water availability, especially the stream size (litre/sec) are considered in

the design of basin irrigation systems. These factors determine the shape and size of basins and the enclosing earth bunds as well as the irrigation operations. Tables 6.1 and 6.2 could serve as guides to the matching of soil type, slope, basin width and stream size for a typical basin design. The general layout (figure) comprises an inlet canal, the check basin, dykes or retaining bunds and a drainage channel.

### Design example

If the major slope in the field is about 0.3, with Table 6.1, you can determine the maximum width of each basin to be 37m but could also range between 30 – 45m. Supposing the soil texture in the field is sandy loam, you have the option of choosing your basin either based on the area (m<sup>2</sup>) if you are not constrained by stream size or determine the maximum area possibly if your stream size is already determined. From Table 6.2, with a stream size of 10l/sec, and sandy loam, the basin area is 200m<sup>2</sup>

$A = L \times B$ ; From Table 5.1, the chosen length is 37m therefore,  $B = 200/37 = 5\text{m}$ . Based on the field topography, L and B should be set out. It is also possible to simply make the basin square and much smaller, especially on a steep slope or when the stream size is far small. 1: Approximate slope and maximum basin width (m).

**Table 6.1: Approximate slope and maximum basin width (m)**

| Slope % | Maximum width (m) |         |
|---------|-------------------|---------|
| 0.2     | 45                | 35 - 55 |
| 0.3     | 37                | 30 - 45 |
| 0.4     | 32                | 25 - 40 |
| 0.5     | 28                | 20 - 35 |
| 0.6     | 25                | 20 - 30 |
| 0.8     | 22                | 15 - 30 |
| 1.0     | 20                | 15 - 25 |
| 1.2     | 17                | 10 - 20 |
| 1.5     | 13                | 10 - 20 |

| Slope (%) | Maximum width (m) |        |
|-----------|-------------------|--------|
| 2.0       | 10                | 5 - 15 |
| 3.0       | 7                 | 5 - 10 |
| 4.0       | 5                 | 3 - 8  |

(Source: FAO, 1985)

**Table 6.2: Suggested Maximum Basin Areas (m<sup>2</sup>) for various soil types and possible stream sizes (l/sec)**

| Stream size (l/s) | Sand | Sandy loam | Clay loam | Clay |
|-------------------|------|------------|-----------|------|
| 5                 | 35   | 100        | 200       | 350  |
| 10                | 65   | 200        | 400       | 650  |
| 15                | 100  | 300        | 600       | 1000 |
| 30                | 200  | 600        | 1200      | 2000 |
| 60                | 400  | 1200       | 2400      | 4000 |
| 90                | 600  | 1800       | 3600      | 6000 |

(Source: FAO, 1985)

### Basin construction

The construction works for a basin irrigation system usually starts with the basin feeder canals (assuming the rest of the water delivery infrastructure has been done). The basin feeders are constructed as a small canal by forming the banks. These are preferably made straight, running down the slope, and should be parallel to each other. The canals should be constructed above the ground level to allow water flow from the feeder or field canal to the basins (Figure 6.1).

### Considerations in basin construction

- The banks should be about 30 cm high and 30 cm wide at the top and well compacted. This may vary based on the basin size.
- The banks of the basin feeder form one side of the basins. The basins can now be set out according to the designed dimensions.

- The bunds are constructed on the boundaries of the basins. The bunds should be some 20 cm high and about 20 cm wide at the top.
- As with the feeder banks, the bunds have to be well compacted to prevent leakage from one basin to another.
- After the construction of the bunds, the basin needs to be levelled. A simple trick is to fill the basin with water and check for high and low spots and do the levelling.
- This “pre-irrigation” will also make tillage and planting easier.
- After levelling, ridges can be formed in the basins in case ridged basins are required.

On small plots with uniform slopes, it is possible to construct the basins directly.

- This starts with pegging out contour lines at a vertical interval of 10 cm.
- The distance between the contour lines is divided by three. This is the width of the basins. As a result of this method, the basins may be curved and not rectangular.
- The determination of the length of the basin will be guided by the maximum basin size (see Table 6.1 and 6.2) and the location of the basin feeders.
- The basin feeders should be down the slope and parallel to each other.

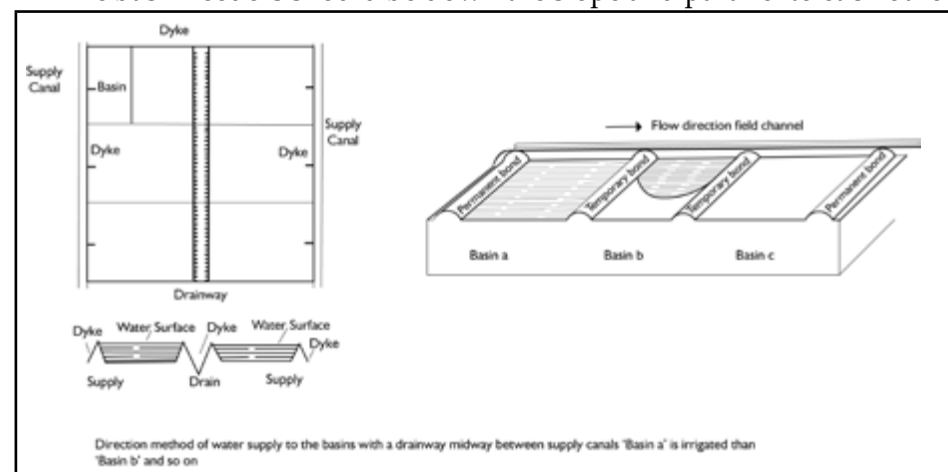



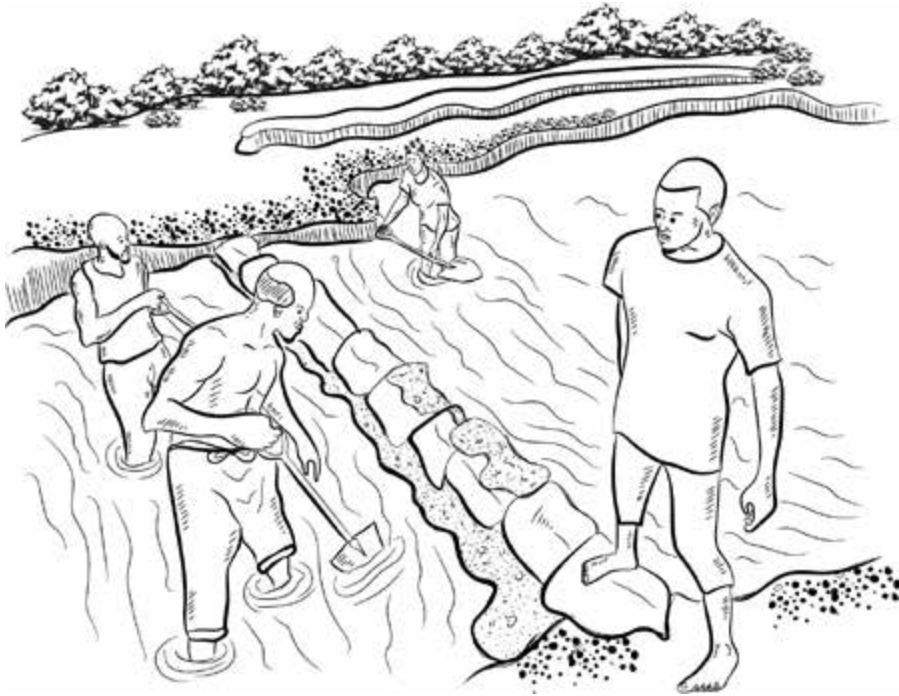

Figure 6.1: Construction guide for basin irrigation

### 6.4.2 Check Basin

A check basin is a rectangular or a square levelled piece of land surrounded by earthen bunds and flooded during irrigation. In size and shape, it is much smaller than a conventional basin. It is formed from earthen bunds or small embankments which retain irrigation water within the check basins. Water is applied to check basins through siphons, spiles or by breaching the dyke to create an inlet (Figure 6.2).

#### *Advantage of check basin*

- Check basins are useful for leaching harmful salts. However, a good drainage system is needed to dispose of excess water.
- Check basin irrigation is suited for smooth gentle and uniform land slopes and for soils having moderate to low infiltration rates.

- It may be used on a steep slope with terracing. However, steep slopes require complex layouts and more land levelling.
- Both row crops and close-growing crops are adapted to check basins as long as the crop is not affected by temporary inundation or is planted in raised beds so that it will remain above the water level.
- The method is specially adapted for irrigation of grain and fodder crops in heavy soils where water is absorbed slowly and is required to stand for a relatively long time to ensure adequate irrigation.

#### *Check Basin operation*

- Water flows into the field through the main drain or channel.
- With the use of control devices such as sluice gates or weirs, the field drain is fed.
- Water is let into the check basin in successive orders from 1, 2, to 8 (Figure 6.2) using spiles or by breaching the feeder line/drain.
- Where the feeder line is big enough, two or more check basins can be watered at the same time.
- Sufficient water is left in the check basin and allowed to infiltrate to meet the irrigation requirement.

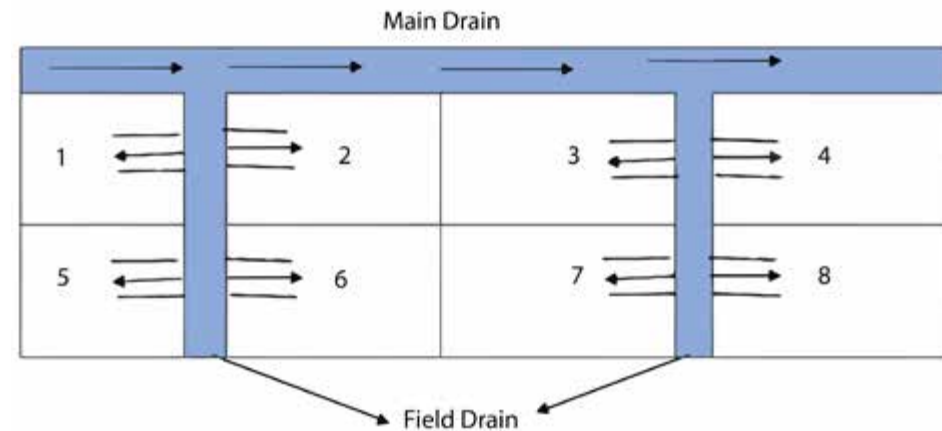

Figure 6.2: Check basin layout

### Check basin with closed pipe conveyance

- In a pressurized system where a closed pipe is used, a check basin may receive water directly from the pipe network.
- This system where water is conveyed using pipes has been found to reduce water conveyance losses and have performed well in the use of check basin irrigation for rice and wheat production.
- This is particularly suitable where shallow groundwater tube well with a small pumping machine is used.

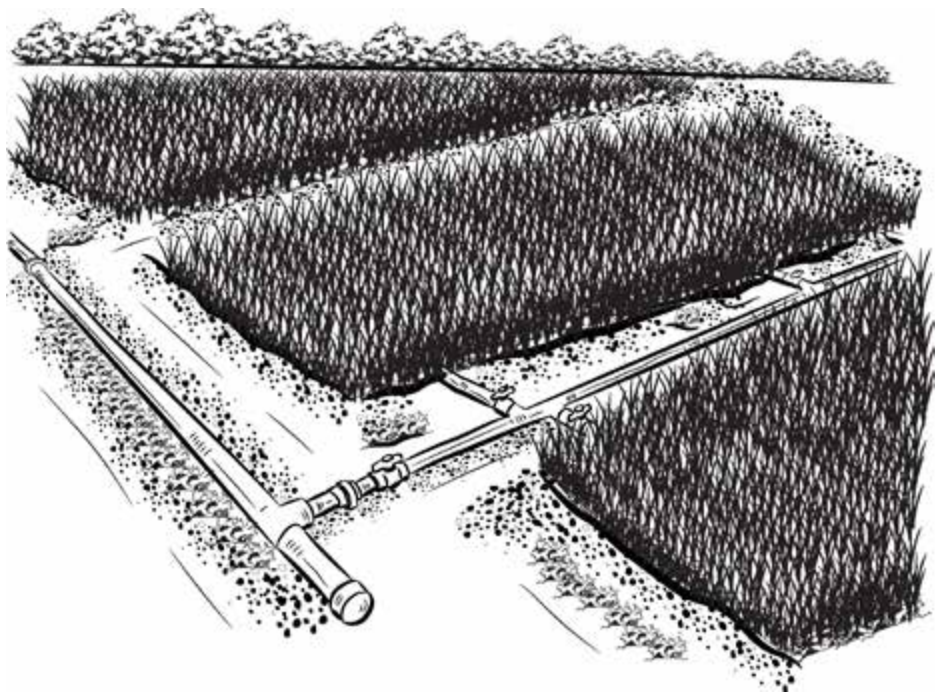

Figure 6.3: Rice production in check basin with piped water conveyance network

### 6.5 Border Strips

Border strips are strips of land with irrigation water applied to flow on a downward slope usually in a rectangular shape. Border strips can vary from 3-30 m in width and 60-800 m in length. They are separated

by parallel dykes or border ridges (levées). It is this longer length of the border strip that differentiates it from the basin or check basin. However, the hydraulics and conditions for efficient irrigation are nearly the same.

### Application domain

- Border strips are very appropriate for close-growing crops such as sugar cane, grass, cereals and vegetable crops.
- Border strips may apply to smallholder and medium-size farms because of the large area/strip.
- It may be very useful in irrigation schemes where small scale farmers have access to water and are allocated large farm holdings.

### Border strips operation

- Figure 6.5 is the layout of a typical border strip while Table 6.3 gives a guide on the matching soil texture, stream size and the possible area (length and breadth) appropriate for a border strip.
- Normally, water is let onto the border strip from the canal through intakes which can be constructed with gates on the wall of the canal or when unlined canals are used by temporarily making an opening in the canal wall.
- The latter is not recommended since it weakens the walls of the canal, leading to easy breakage. Another means used for the same purpose is the insertion of short PVC pipes into the canal through the wall.
- The short pipes are usually equipped with an end cap, which is removed when irrigation is practised. Some farmers use cloth or plastic sheets to close and open the pipe.
- The most appropriate method of supplying water from the canal to the field, however, is the use of siphons (FAO, 2002).

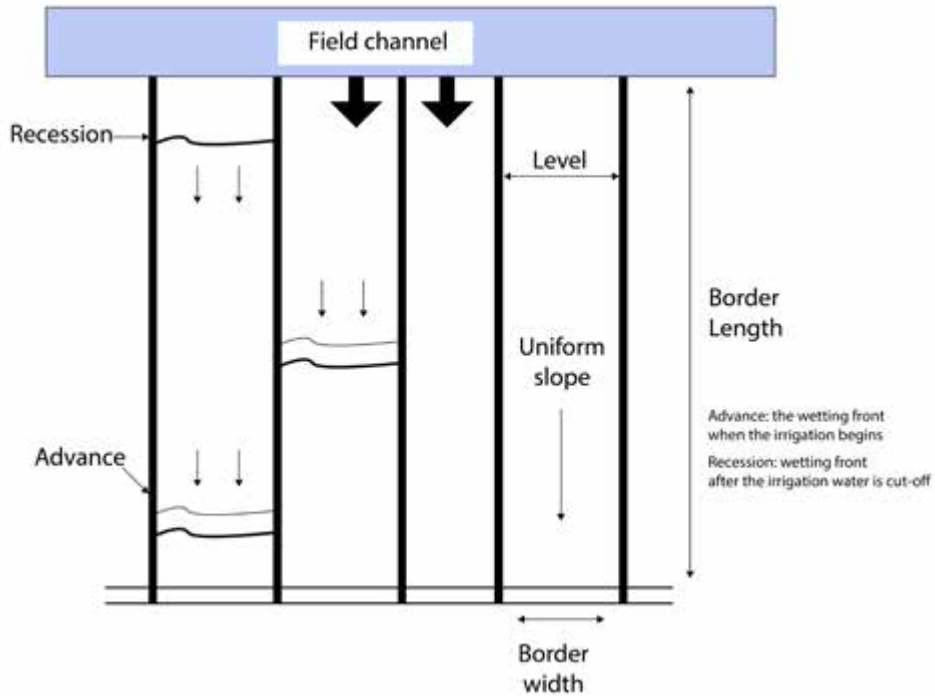

Figure 6.4: Border strips layout  
(Source: FAO, 2002)

Table 6.3: Approximate Slope, width and length for border strips construction (Source: FAO, 2002)

| Soil type | Slope | Depth of water applied | Flow (l/sec) | Strip width | Strip length |
|-----------|-------|------------------------|--------------|-------------|--------------|
| Coarse    | 0.25  | 50                     | 240          | 15          | 150          |
|           |       | 100                    | 210          | 15          | 250          |
|           |       | 150                    | 180          | 15          | 400          |
|           | 1     | 50                     | 80           | 12          | 100          |
|           |       | 100                    | 70           | 12          | 150          |
|           |       | 150                    | 70           | 12          | 250          |
|           | 2     | 50                     | 35           | 10          | 60           |
|           |       | 100                    | 30           | 10          | 100          |
|           |       | 150                    | 30           | 10          | 200          |
| Medium    | 0.25  | 50                     | 210          | 15          | 250          |
|           |       | 100                    | 180          | 15          | 400          |
|           |       | 150                    | 100          | 15          | 400          |
|           | 1     | 50                     | 70           | 12          | 150          |
|           |       | 100                    | 70           | 12          | 300          |
|           |       | 150                    | 70           | 12          | 400          |
|           | 2     | 50                     | 30           | 10          | 100          |
|           |       | 100                    | 30           | 10          | 200          |
|           |       | 150                    | 30           | 10          | 300          |
| Fine      | 0.25  | 50                     | 120          | 15          | 400          |
|           |       | 100                    | 70           | 15          | 400          |
|           |       | 150                    | 40           | 15          | 400          |
|           | 1     | 50                     | 70           | 12          | 400          |
|           |       | 100                    | 35           | 12          | 400          |
|           |       | 150                    | 20           | 12          | 400          |
|           | 2     | 50                     | 30           | 10          | 400          |
|           |       | 100                    | 30           | 10          | 400          |
|           |       | 150                    | 20           | 10          | 400          |

## 6.6 Furrow

A furrow irrigation system consists of furrows and ridges. Irrigation water is conveyed using small channels or furrows. Irrigation water is applied by either diversion from the field canal, siphons, gated pipes, hoses or PVC pipes built with control. Water can be diverted from the field canal or gated pipes. The water is gradually absorbed into the soil and spreads laterally to wet the area between the furrows. Just as it is with basin and border strip, irrigation depends on the soil type, topography, the length of time for irrigation (FAO, 2002).

Furrow irrigation is quite simple as no extra land preparation is required after the furrow or ridge is constructed for crop planting. Water infiltrates along the furrow as the water flows along the slope.

### Application domain

- Furrows can be used on most soil types, although coarse sands are not recommended since percolation losses would be high because of high infiltration rates.
- The method is best suited to row crops such as maize, potatoes, onions, tomatoes, etc.
- Furrow irrigation may have limited efficiency. When the slope is high, contact time for infiltration will be very low. There is also the possibility of erosion when applied irrigation water or rainfall is high.
- Furrow shape and design depends on soil type (Figure 6.3). Table 5.4 is a guide on the choice of soil type, slope and stream size for a range of irrigation application rates. However, local adaptation may be required to achieve an efficient application rate.

### Furrow irrigation operation

- The furrows can be constructed using either animal or tractor drawn implements such as ridges or moldboard ploughs.
- The furrow is constructed along the slope. It is most appropriate in the landscape with gentle slopes (1 – 10%).
- The higher the slope, the possibility of erosion if the stream size is also

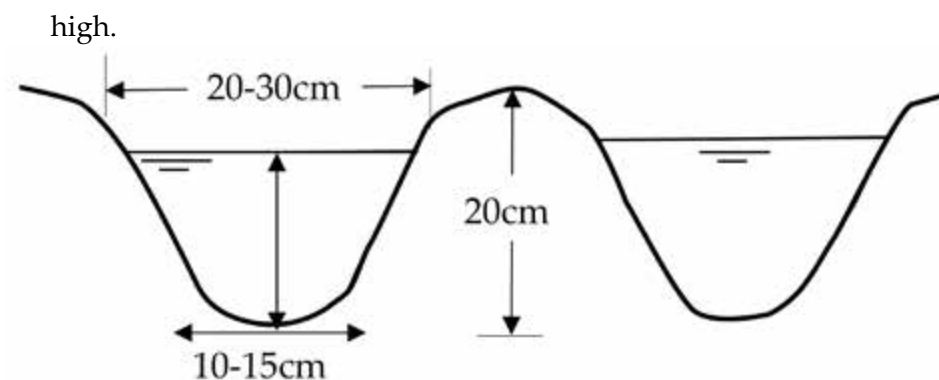

a. Deep narrow furrow on sandy soil

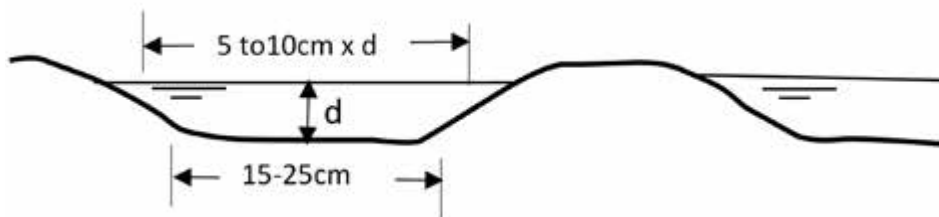

b. Wide shallow furrow on clay soil (Source: FAO 2002)

Figure 6.5: Furrow shape based on soil type

**Table 6.4: Soil type, slope and stream sizes for furrow irrigation practice (Source FAO, 2002)**

| Soil type    |                     | Clay                               |     | Loam |     | Sand |     |
|--------------|---------------------|------------------------------------|-----|------|-----|------|-----|
|              |                     | Net Irrigation requirement in (mm) |     |      |     |      |     |
| Furrow slope | Stream size/ furrow | 50                                 | 75  | 50   | 75  | 50   | 75  |
| 0.0          | 3.0                 | 100                                | 150 | 60   | 90  | 30   | 45  |
| 0.1          | 3.0                 | 120                                | 170 | 90   | 125 | 45   | 60  |
| 0.2          | 2.5                 | 130                                | 180 | 110  | 150 | 60   | 95  |
| 0.3          | 2.0                 | 150                                | 200 | 130  | 170 | 75   | 110 |

|     |     |     |     |     |     |    |     |
|-----|-----|-----|-----|-----|-----|----|-----|
| 0.5 | 1.2 | 150 | 200 | 130 | 170 | 75 | 110 |
|-----|-----|-----|-----|-----|-----|----|-----|

### 6.6.1 Efficient Water Application Pattern in Furrow

If the shape of the furrow is properly selected and constructed, moisture distribution in the ridge should be even and will cover the crop root zone sufficiently. Figure 5.6 illustrates an even distribution of moisture in well-spaced and adequately irrigated furrow ridges.

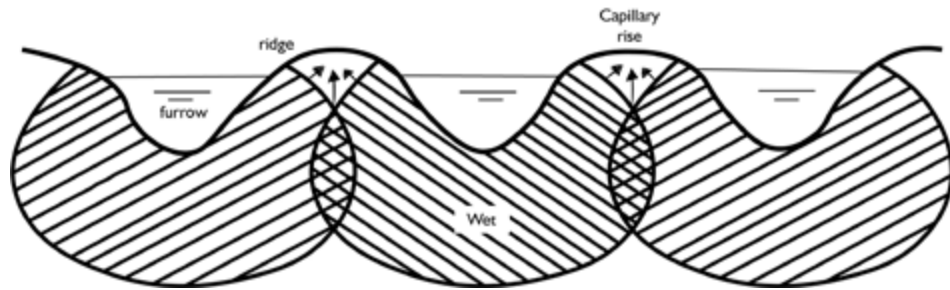
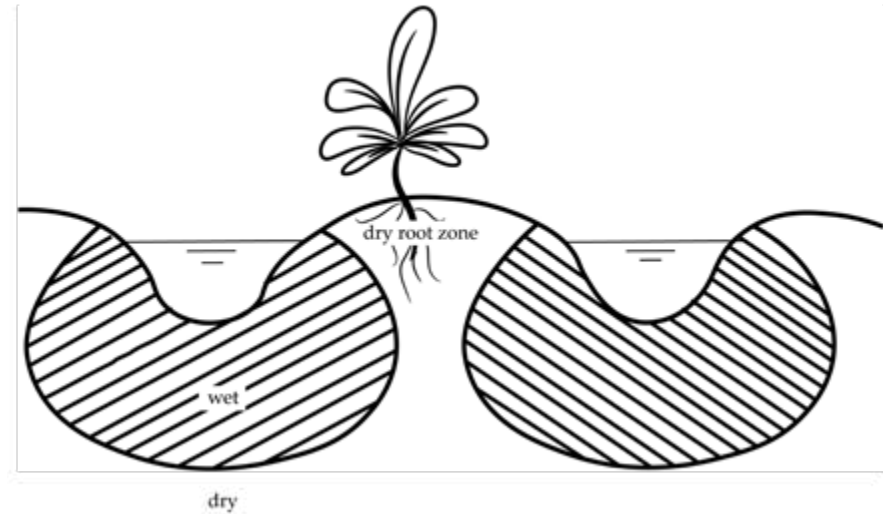
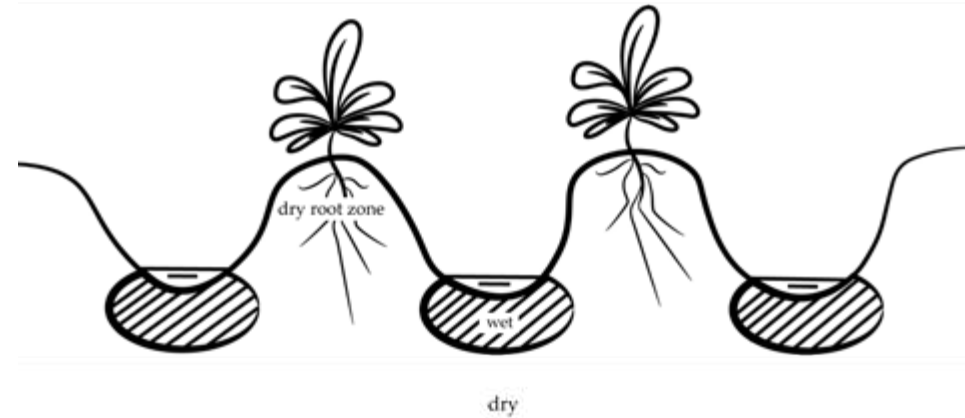

Figure 6.6: Ideal moisture distribution in furrow ridge (Source: FAO, 1985)

In contrast, Figure 6.7 shows three (3) major conditions that show poor water application and moisture distribution in-furrow system.



The spacing between adjacent furrow is too wide



Stream size is too small to wet the ridge

(Source FAO, 1985)

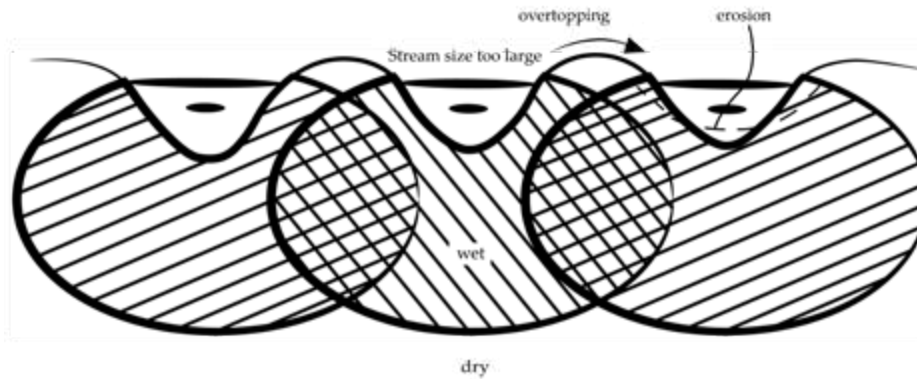

The stream size is too large resulting in overtopping

Figure 6.7: Major conditions of poor furrow irrigation (Source: FAO, 1985)

### 6.6.2 Planting Considerations in Furrow Irrigation

Planting positions in-furrow systems may be adjusted based on field considerations, water salinity, rainfall and soil type. Three (3) potential planting positions based on the above considerations has been illustrated below.

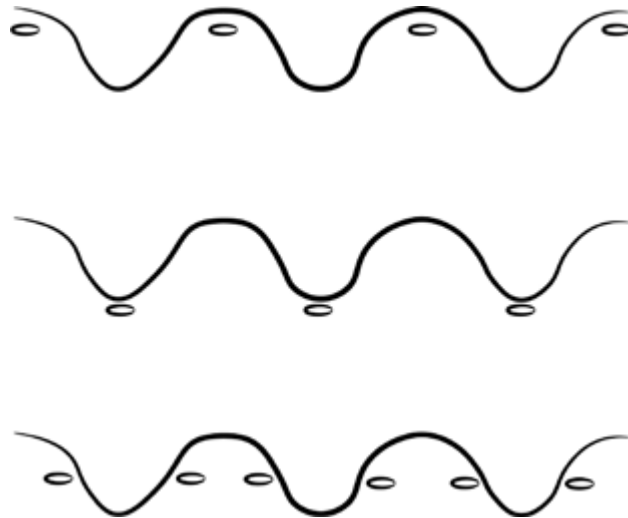

### 6.7 Operation and Maintenance

Surface irrigation structures require regular maintenance.

- It is important to check the bunds regularly; identify defects and repair them instantly before damage is done.
- The bunds (temporary or permanent) are susceptible to erosion which may be caused by rainfall, flooding or the passing of people when used as footpaths.
- Moles sometimes dig holes in the sides of the bunds which may trigger bunds failure and erosion.
- Before each growing season, the basins should be checked to see that they remain level.
- During pre-irrigation, it can easily be seen where higher and lower spots are; there should be smoothed out. Also, the field channels should be kept free from weeds and silt deposits.
- Surface irrigation, if not well designed, can suffer poor water distribution patterns, under-irrigation or over-irrigation. Another limitation is that, in basin irrigation, too many ridges do not only occupy the land but also hinder other agronomic operations as well as the use of machinery.

## More Information

027E Surface Irrigation <https://www.youtube.com/watch?v=Ya5ikTKZgIo>  
(Accessed December 5, 2020)

## Disclaimer

The mentioning of any equipment brand, illustrated or explained in this module is for the purpose of training. The IWMI does not promote any brand of equipment and will not take responsibility for the choice of any brand.

## Acknowledgement

All the illustrations used in this manual have been appropriately cited. Any omission is hereby highly regretted.

The video on *Surface Irrigation* is from the Irrigation Toolbox YouTube channel.

All the illustrations used in this manual have been appropriately cited. Any omission is hereby highly regretted.

All the photographs used in this manual are courtesy of IWMI.

## Bibliography

Savva, A. P. & Frenken, K. (2002). Surface Irrigation systems. Planning, Design, Operation and Maintenance. FAO, 2002.

Irrigation Water Management: Irrigation Methods Training manual no 5. FAO, Rome, 1985

# MODULE 7

Sprinkler Irrigation Systems





# Sprinkler Irrigation Systems

## 7.1 Sprinkler Irrigation Technology

Sprinkler irrigation is an irrigation method where irrigation water is applied in a way similar to natural rainfall. It mimics rainfall events and combines the use of conveyance pipes and sprinklers; devices with predetermined orifices through which water is jetted out under pressure. The fundamental difference between the sprinkler system and surface irrigation is that whereas in surface irrigation, the field surface is used to convey the water across the field, in the sprinkler system, the irrigation water is conveyed through pipes under pressure. Energy from the pump is required to achieve water spray. Different sprinkler types are usually designed to operate under specific pressure and when this pressure rating is not met, the performance of sprinklers is reduced. However, to achieve good sprinkler irrigation, other conditions must be considered in designing the system. These include the area to be irrigated in an irrigation event, soil type, crop type, landscape topography, distance to the water source, field elevation, wind characteristics and possible energy sources for pumping. Sprinklers come in different capacities, nozzle diameter and numbers, discharge or application rate and rotation mechanisms. These parameters should be properly matched with soil type and crop water demand to ensure the high efficiency of a sprinkler irrigation system. This module provides a basic operation guide for the use of sprinkler irrigation technology in a smallholder system.

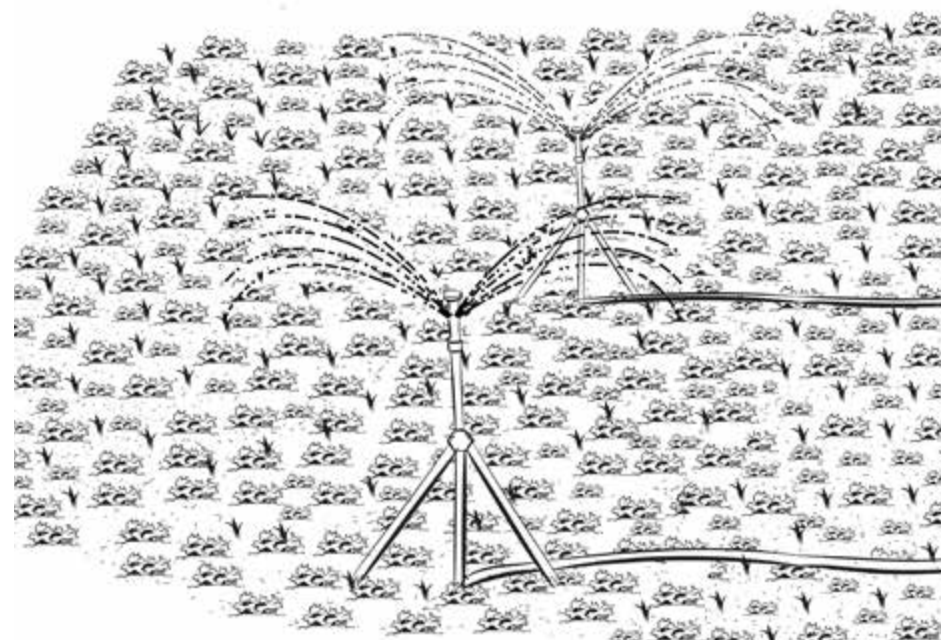

## 7.2 Potential Benefits

When properly designed and operated, sprinkler irrigation gives a better uniformity and could result in higher irrigation efficiency than surface irrigation practices. Sprinkler irrigation has wide applications in most landscapes. It is adaptable to small and large farms with the right design. The system has high irrigation efficiency. The implementation of sprinkler irrigation can reduce irrigation water losses from the use of conveyance channels, improve the efficiency of field application and use for different crops. The system has a long life span. The use of properly designed, installed and operated sprinkler irrigation saves irrigation water per hectare when compared with surface irrigation while increasing crop yield. Table 7.1 is an example of water saved and increased yield when sprinkler irrigation systems are used.

**Table 7.1: Yield and water saved in sprinkler irrigation in India (Source: INCID, 1998)**

| Crop        | Water saving % | Yield increase % |
|-------------|----------------|------------------|
| Barley      | 56             | 16               |
| Cabbage     | 40             | 3                |
| Cauliflower | 35             | 12               |
| Chillies    | 33             | 24               |
| Cotton      | 36             | 50               |
| Groundnut   | 20             | 40               |
| Maize       | 41             | 36               |
| Onion       | 33             | 23               |
| Potato      | 46             | 4                |
| Wheat       | 35             | 24               |

Sprinkler system has more advantages. It replaces the field canals with pipe conveyance which is much easier to operate and maintain. The extensive land development (e.g. land levelling) that is required for surface irrigation is often reduced with sprinkler irrigation. Efficient water use also cuts down on costs incurred on gross water requirement especially,

when farmers have to pay for irrigation water.

## 7.3 Application Domains

Sprinkler irrigation has very wide designs with different manufacturer specifications.

- Sprinklers apply to a wide range of crops, especially crops that are grown closely together such as cereals, pulses, wheat, sugarcane, groundnut, cotton, vegetables, fruits, flowers, spices and condiments.
- They are adaptable to different soil types; however, the soil infiltration rates must guide the choice of sprinkler type. The sprinkler's application rate should not exceed the soil infiltration capacity to avoid increased runoff and possible field erosion.
- With the right sprinkler, it can be used in a nursery, seedling production, greenhouses and large fields.
- With increased field size, challenging topography, distance in the water source and poor soil type, more technicality is involved in the design and installation of sprinkler systems.

## 7.4 Investment and Costs Considerations

Sprinkler irrigation equipment investment, when properly maintained, can be used for more than 20 years. Investment costs of a sprinkler system are between 5,000 - 8,000 US\$/ha for a conventional sprinkler system with aluminium pipes main lines and laterals, although the cost may be lower with HDPE or PVC pipes. The operational cost, however, may be high due to the energy required for pump operation to achieve the pressure requirement. Labour requirement – for the movement of laterals and risers – is another major consideration especially when the sprinkler system is not a Solid Set – where the main lines, laterals and riser with sprinkler are in a permanent position in the field.

## 7.5 Design and Installation

For any sprinkler irrigation method to be successful at the planning stage, the irrigator/farmer must have basic information which will enable decisions to be made on system capacity. Basic information required for sprinkler irrigation installation include:

### 7.5.1 Irrigated Area

The area to be irrigated at a time should be known. The bigger the area to be irrigated at a time (per irrigation event), the more the investment in terms of sprinkler pipes, laterals and pump capacity. However, the field may be partitioned into blocks of the smaller area while the conveyance system is designed to enable the connection of sprinkler lateral(s) for the irrigation of other blocks. The blocks should be of similar dimension as much as it is practicable so that moving the sprinklers to irrigate the next block will be with little adjustment.

Figure 7.1 is an example of how a field can be partitioned into blocks. Depending on the water source and feasible pumping station, the mainline can be laid either at the middle of the field or at the boundary. Sub-mainline may be required if the blocks are large.

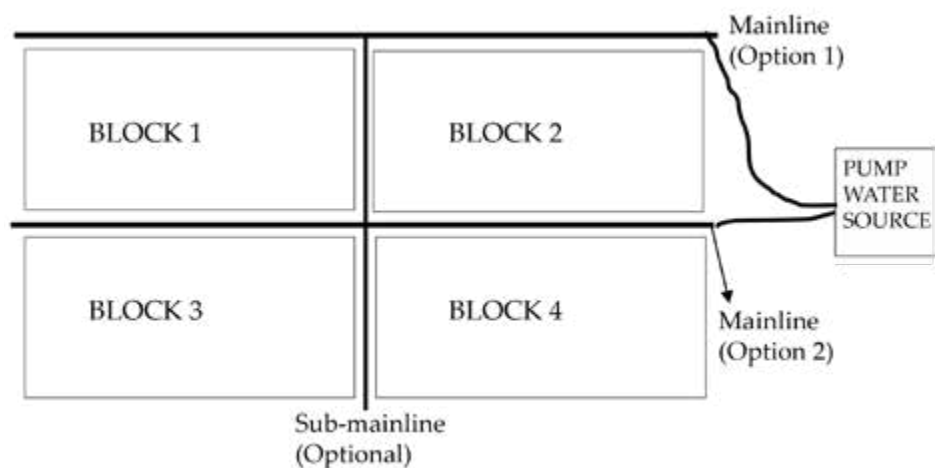

Figure 7.1: Partitioning of a field into blocks

The volume of water you will need during the life cycle of the crop must be evaluated based on the total area to be cropped.



### 7.5.2 Description of Sprinkler System Components

#### Sprinklers

A sprinkler is a device used to spray water under pressure. Depending

on the design, the spray or drop size can be mist, fine or coarse. The area covered at a time which is usually in a circle is called the wetted diameter. The appropriate sprinkler should be chosen based on crop type, soil textural characteristics, weather conditions, especially wind direction and speed.

**Table 7.2: Descriptions of different types of sprinklers for irrigation**

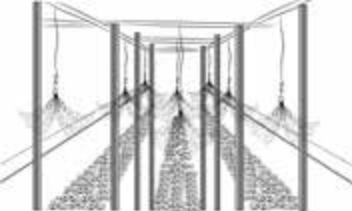
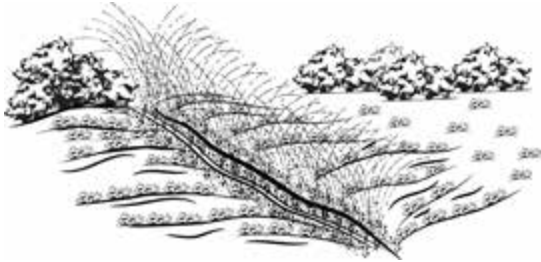
| Sprinkler type                    | Descriptions  | Possible application  | Image  |
|-----------------------------------|---|---|--|
| Impact sprinkler                  | <ul style="list-style-type: none"> <li>▪ The sprinkler head is driven in a circular motion by the force of the outgoing water</li> <li>▪ It rotates 360° and discharges based on the nozzle diameter.</li> <li>▪ It comes with either a single or double nozzle.</li> <li>▪ Requires high pressure for efficient operation.</li> </ul>                        | <ul style="list-style-type: none"> <li>▪ Applicable for most crops and most soil types.</li> <li>▪ It requires mounting on a riser which should be above or close to the highest height of the irrigated crop's canopy.</li> <li>▪ It can be easily mounted on a mobile riser and used singly for a small area or in multiple.</li> </ul> |  <p data-bbox="1720 172 2063 443">                     Bearing: 1/2" Male NPT, Brass<br/>                     Trajectory Angle: 23 degrees<br/>                     Operating Range: 20-80 psi (1.4-5.5 bar)<br/>                     Flow Rate: 1.56-6.35 gpm (0.35-1.44 m³/h)<br/>                     Radius: 35-46 ft. (10.8-14.2 m)<br/>                     Nozzle Port: 1/4" Female NPT                 </p> |
| Spray gun or Gun Sprinkler        | <ul style="list-style-type: none"> <li>▪ It is a bigger design of the impact sprinkler. It gives long throw and is useful for big coverage at a time.</li> <li>▪ Requires high energy/pressure.</li> <li>▪ It is mounted on either a tripod or some designs and comes with the self-propelled system and travelling hose.</li> </ul>                          | <ul style="list-style-type: none"> <li>▪ Most applicable to cereals and other crops with high plant heights e.g., orchards and cereals.</li> <li>▪ Useful when limited laterals are intended.</li> <li>▪ Easy to connect to a hydrant and move around.</li> </ul>   |   |
| Pop-up sprinkler                  | <ul style="list-style-type: none"> <li>▪ This sprinkler pops up when under pressure and closes when not in operation.</li> <li>▪ It comes with devices for adjustment of and rotation type (360°, 180°, 50°).</li> <li>▪ It requires pressure for efficient operation.</li> </ul>   | <ul style="list-style-type: none"> <li>▪ Most appropriate for lawn, close grown crops, crops with short plant height, vegetables and nurseries.</li> <li>▪ The wetted diameter is not high.</li> <li>▪ It is easy to manage in small irrigated areas.</li> </ul>  |   |
| Hanging micro/fog sprinkler       | <ul style="list-style-type: none"> <li>▪ It is a sprinkler with very low discharge.</li> <li>▪ The discharge comes like a mist or fog.</li> <li>▪ It requires low pressure.</li> </ul>  | <ul style="list-style-type: none"> <li>▪ Useful where heavy water high water application is not needed.</li> <li>▪ Appropriate in nurseries and greenhouse production.</li> <li>▪ For temperature and humidity conditioning.</li> </ul>   |    |
| Spray tube or Rain Hose sprinkler | <ul style="list-style-type: none"> <li>▪ This sprinkler comes in a pre-sized perforated tube, usually 3 holes per point spaced at 25cm</li> <li>▪ Water is sprayed from the holes on the tube when operated under pressure.</li> <li>▪ The tube is connected to the mainline and the lines are spaced at 2m to ensure good coverage when operated.</li> </ul> | <ul style="list-style-type: none"> <li>▪ Applicable to vegetables, crops grown on beds and close grown crops</li> <li>▪ Appropriate where the soil can accommodate a high application rate</li> <li>▪ Require clean water, non-turbid and no dissolve solid.</li> </ul>   |   |

### 7.5.3 What to Look for in Your Sprinkler

- *Discharge rate and pattern:* As highlighted in the Table 7.2, sprinklers come in different designs and discharge rate which is determined by the nozzle size, numbers and operating pressure.
- *Drop size – mist or fog, small or coarse,* different sprinklers produce different drop sizes.
- *Operating pressure:* The operating pressure must be maintained for sprinklers to give maximum performance. It is also important to reduce the effect of wind. Spray guns and impact sprinklers may require up to 2-4 bar while micro-sprinklers and spray tube require 2-3 bar of pressure. Fluctuation and inadequacy in operating pressure reduce the application efficiency of the irrigation.
- *Wetted diameter or Radius of the spray:*
- Rotation type (full circle, 360°, 270° or 180°)
- The material of make (plastic, metals – brass or silver). This may suggest durability.

### 7.5.4 Water Conveyance System

Pipes and hoses are the main conveyance material in sprinkler irrigation. The pipe could be of Aluminum, High-Density Polyethylene (HDPE) or Poly Vinyl Chloride Pipes (PVC) materials. These materials are the most commonly used pipes in the field. In nurseries and greenhouses where micro sprinklers are required, these pipe materials may be operated with high pressure. Appropriate hose lines and drag hoses may also be used for micro-sprinklers and gun sprinklers. Investment capacity, land tenure type, crop and sprinkler irrigation methods are among the major consideration in the choice of the type of conveyance materials. (See Module 4).

### 7.5.5 Layout Methods

Sprinkler irrigation layout typically comprise Mainline, Sub mainline (optional), laterals and risers

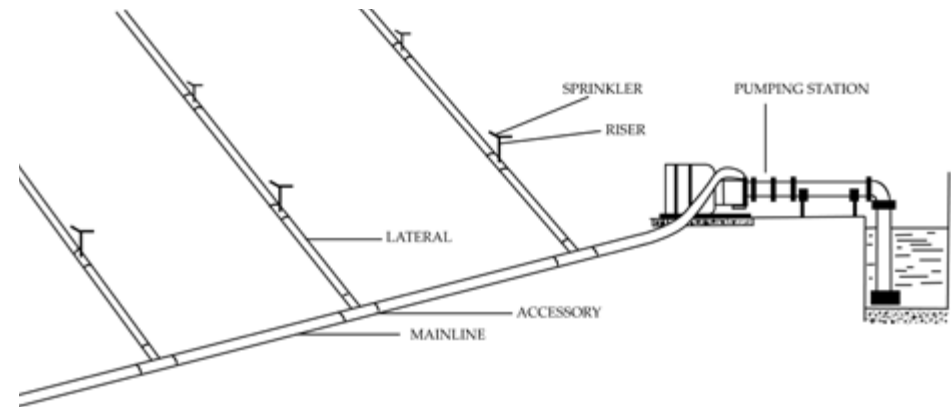

Figure 7.2: Different components of sprinkler system (Source: FAO, 1985)

**Mainline:** The water conveyance pipes directly from the pump.

**Sub-mainline:** In large fields, a sub-mainline takes water from the mainline into the block/sub-area where the lateral can be connected to the field the sprinkler riser in the field.

**Laterals:** This is the water line that connect to risers or directly to the sprinkler heads. The lateral can be HDPE or PVC pipe or a drag hose.

**Solid set:** The layout has the mainline buried with hydrant points for connection of laterals shooting out of the buried pipe. The laterals and risers are all in place and are not shifted to other parts of the field during the irrigation season.

**Semi-Solid set:** The mainline is buried with hydrant points for connection of lateral. But the laterals, hose and risers are mobile and can be moved to another block.

**Mobile set:** In this case, the mainline and the hydrants are not buried. The laterals and risers can be moved to other parts of the field. At the end of the irrigation season, all the components are removed for safe keeping.

## 7.5.6 Spacing Arrangements for Selected Sprinklers

### *i. Conventional sprinklers mounted on laterals*

Water discharged from a single sprinkler may not be uniformly distributed over an area. To ensure uniform precipitation over the entire area under irrigation, the sprinklers are always placed so that they overlap each other from both directions. This placement or arrangement of sprinklers is termed as sprinkler spacing (Figure 7.3).

Sprinklers are mounted on the lateral lines at an equal spacing between 6m and 18m. The laterals are also spaced at specific intervals of 6m and 18m. The spacing of the sprinklers along the lateral lines is known as  $S_L$ , and the spacing between two lines as  $S_m$ . The spacing pattern may be square, rectangular or triangular. If  $S_L = S_m$ , for instance, 6m x 6m means the laterals are spaced at 6m while sprinkler risers are mounted on the lateral at 6m. The spacing can also be 8m x 8m or 12m x 12m.

The choice of the spacing depends on the wetted diameter of the sprinkler and the wind characteristic in the field. To obtain good distribution, uniformity and good overlap, the sprinkler spacing ( $S_m$ ) should not exceed 65 per cent of the sprinkler wetted diameter coverage under light to moderate wind conditions in the square and rectangular patterns. With the  $S_L$  and  $S_m$  determined, the no of sprinklers on a lateral can be determined based on the length of the field/block and the sprinkler spacing on each lateral,  $S_L$ .

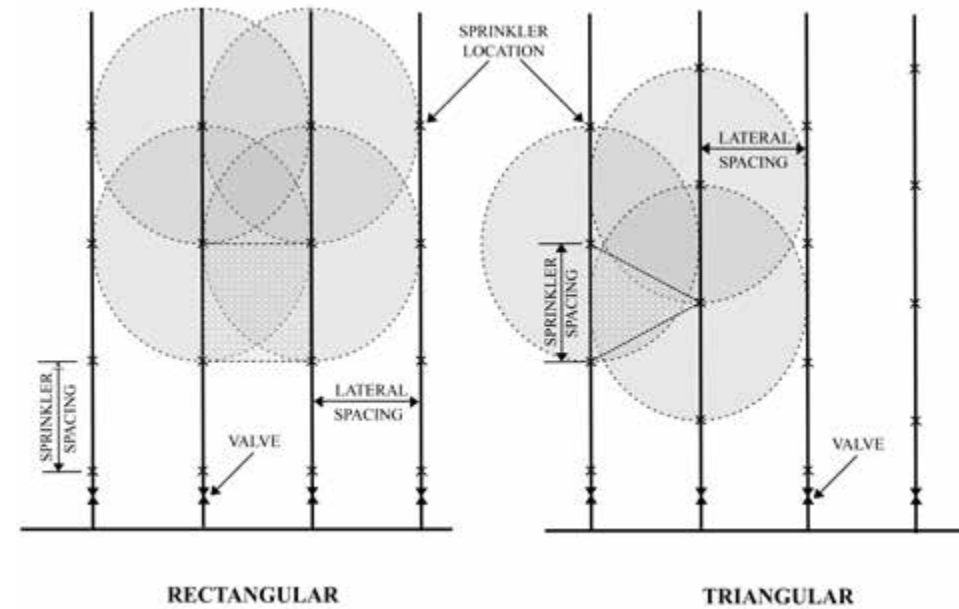

Figure 7.3: Sprinkler layout in rectangular or triangular arrangement  
(Source: Stephanie and Andrew, 2014)

In the triangular pattern, the spacing can be extended up to 70 percent of the diameter coverage. In strong wind conditions, the spacing may be reduced up to 50 per cent of the diameter coverage and the lateral direction perpendicular to the wind direction. If the wind speed is over 3.5 m/s, sprinkling is not recommended.

### *ii. Hose-move and gun spray sprinklers*

The hose-move and tripod-mounted gun-spray sprinklers are designed to reduce the number and movement of laterals which often require substantial labour. These sprinkler types are developed as improvements on the conventional hand-moved pipe lateral system.

- The hose-move and gun spray use giant sprinklers operating at high pressure with wetted diameters between 20m and 90m or more.
- The wetted diameter usually depends on the manufacturer's specification.

- The sprinkler tripod is positioned at a space up to half the wetted diameter, so the throw can cover up to the wetted perimeter.
- Wind may significantly affect the throw and efficiency of gun-spray sprinklers.
- To account for wind, depending on how strong the wind is, consider between 60 and 80% of the wetted perimeter.
- The sprinklers, mounted on tripod stands, are not fitted directly to the lateral pipes but connected to them via flexible PE hoses which are 20–25 mm in diameter and up to 30 m in length.

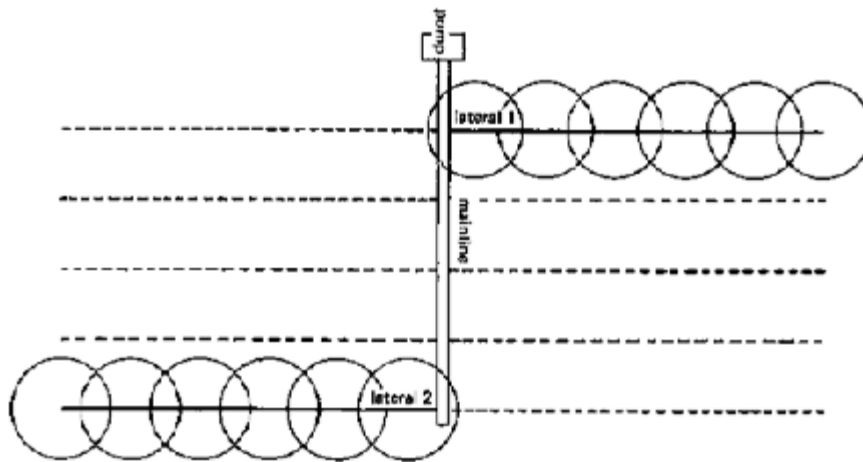

Figure 7.4: Example of layout for gun-spray sprinkler (Source: FAO, 1985)

### iii. Rain Tube/Hose Sprinklers

The Rain Tube or Rain Hose is a recent invention. It is a 40mm diameter flexible hose with pre-punched 3 holes spaced at about 25cm on the upper side of the tube. The Rain Tube comes in a roll of 100m for some brands. It is installed through a connection to the mainline. Each Rain Tube line is spaced at 2m on the mainline (See Module 4 for pipe conveyance installation).

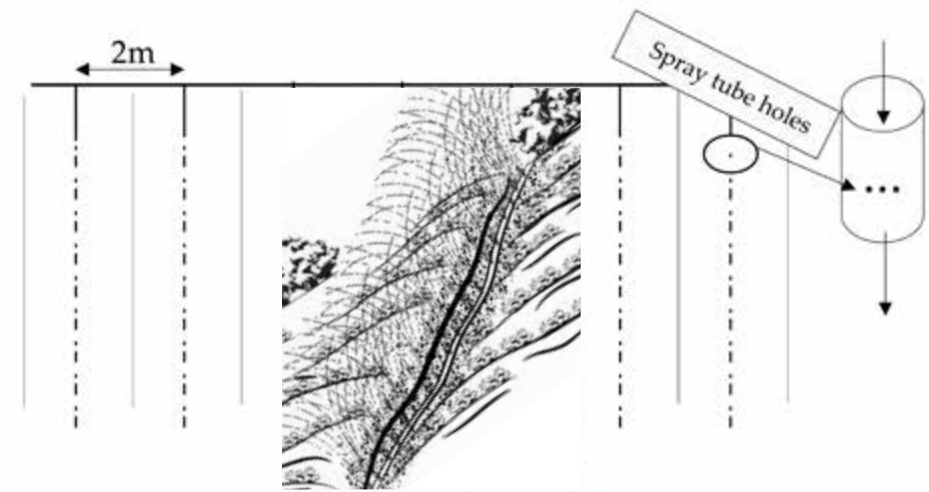

Figure 6.4: Rain tube installation

The length of the rain house is determined by the width of the field to be irrigated. Thus, the roll of 100m is cut to the preferred length based on the field size.

## 7.6 Installation Guide

### Step 1:



- Decide on what type of sprinkler system is most appropriate for the crop and soil type intended to irrigate. This is based on different factors earlier discussed and the level of investment.
- Decide on the pipe conveyance material
  - OPTION 1: Pre-fabricated aluminum based conveyance pipes. This is procured and simply laid following the coupling links provided.
  - OPTION 2: HDPE/PVC assembled conveyance system (Module 4)



### Step 2

- Follow the pipe conveyance system principles in Module 4.
- Determine the sprinkler type (consider the 3 sprinkler types described above), discharge capacity and application rates (Table 6.2).
- Determine the size of pipes for the mainline and laterals.
- Determine the number of laterals based on the lateral and sprinkler spacing chosen.
- Lay HDPE or PVC pipes mainline, laterals and risers.
- Follow the pump capacity using the guide in Module 2

### Step 3

- If gun spray sprinkler is chosen
- Determine the lateral spacing
- Determine the hydrant spacing on the mainline or sub mainline
- Connect with the sprinkler tripod

### Step 4

- Connect the mainline to the pump
- Ensure that the installed valves are opened
- At first pump operation, flush the system by opening the lateral ends to force all debris in the line out
- Close the lateral ends, put on the pump and observe the sprinkler's performance
- Observe the performance of the sprinklers, the discharge, throw, and rotation
- Observed the uniformity

## 7.7 Operation and Maintenance

- Be careful to operate the pump optimally to achieve needed pressure at the sprinklers.
- Pump maintenance is very important – check the oil, fuel and general performance.

- Sediments and debris must not be allowed into the pipe system. This can adversely affect the sprinklers and overall irrigation performance.
- Ensure that the pipes are well protected from tillage equipment and pilfering.
- Pack all sprinklers and pipes after the season's operations and keep them dry, safe and secured.

## Disclaimer

The mentioning of any equipment brand, illustrated or explained in this module is for the purpose of training. The IWMI does not promote any brand of equipment and will not take responsibility for the choice of any brand.

## Acknowledgement

All the illustrations used in this manual have been appropriately cited. Any omission is hereby highly regretted.

All the photographs used in this manual are courtesy of IWMI. The sprinklers are from Jain Irrigation and Jai Agrotech Agency

## Bibliography and Further Reading

Food and Agricultural Organization (1985). Irrigation Water Management: Irrigation Methods. Manual 5. Rome Italy.

Stephanie, T. & Andrew, P. (2014). B.C. Sprinkler Irrigation Manual (2014). Ed. Ted W. Gulik, British Columbia, Ministry of Agriculture.

Sprinkler Irrigation in India (1998). Indian National Committee on Irrigation and Drainage. Sprinkler Irrigation in India. INCID, New Delhi

Phocaidés, A. (2007). Handbook on Pressurized Irrigation Techniques. Second Edition. Food and Agriculture Organization of the United Nations Rome, 2007



# MODULE 8

Drip Irrigation Systems



# Drip Irrigation Systems

## 8.1 Drip Irrigation Practices

Drip irrigation is a method by which water is applied slowly at a predetermined rate to the crop directly. It is a low-pressure system that uses devices called drippers or emitters installed at specific points along the water lines or driplines. The arrangement of the drippers follows the planting spacing and crop stands. The design of drip irrigation is to enable irrigation of the crop root zones. Water is supplied in drops or trickles continuously in such a way that the root zone is kept wet. Water is delivered to the root zones and not directly to other areas outside the area of interest. This is why drip irrigation gives the highest water use efficiency in comparison to other irrigation practices. A well designed and managed drip system can give up to 95% irrigation efficiency. This is because there is practically no loss of water in a conveyance; very reduced loss of water to soil evaporation and efficient water delivery to the crop which also ensures high crop water use efficiency.

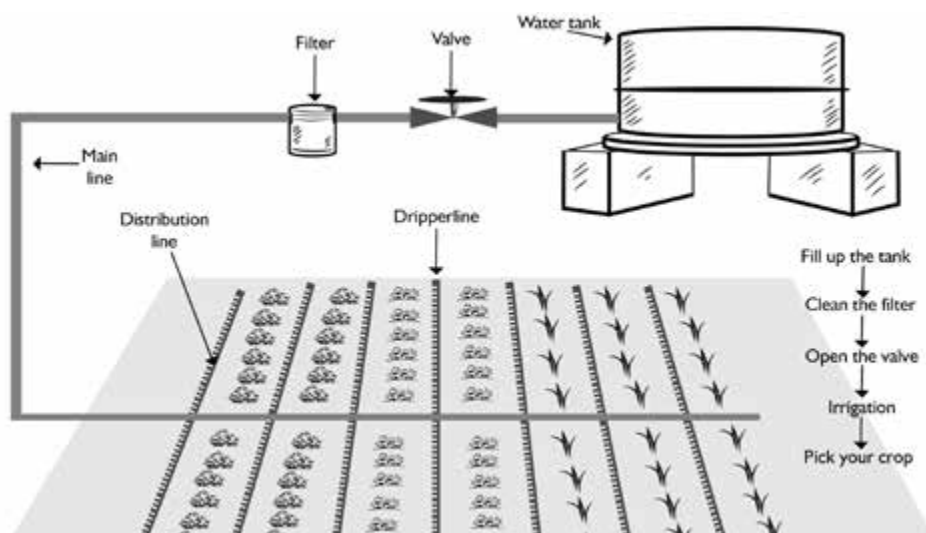

(Source: NETAFIM)

## 8.2 Potential Benefits

Drip irrigation is the most advanced irrigation method with the highest irrigation application efficiency. Water is delivered over an extended period, for instance for several hours – probably up to a day – in hot weather. The crop growth medium around the root zone is irrigated directly with wetting vertically by gravity and laterally by capillary action. The drip system operates under very low pressure which reduces the energy requirement in the system. In Kenya, a low-cost small-scale drip irrigation system was shown to generate 2.8 more yield and use 45% less water compared to the existing practice of irrigation with buckets. In Tanzania, drip irrigation provided a tea yield four times higher than that of the rainfed, non-irrigated tea. Similarly, in Sudan, drip irrigation saved irrigation water by 60% and increased the yield of onions by 40% compared to surface irrigation (Rodolfo, 2015).

## 8.3 Application Domain

Drip irrigation applies to different soils and is adaptable to a wide range of topography from flat land to steep slopes. The system can be used to grow different crop types. It is especially suitable for row crops and particularly vegetables, cereals and tree crops. A drip system is well suited to crops grown on beds. However, other factors such as cost and benefit may limit the application of the drip system for all crops.

Drip irrigation requires some conditions to achieve high productivity:

- **Good quality water:** Good quality water with extremely low or no sediment, dissolved solids, salinity and non-acidic is required. Some form of pretreatment such as filtration or pH correction of water before use may be required.
- **Soil characteristics:** The general nature of the soil and its characteristics can impact water distribution and crop performance. Heavy clay or gravelly soils are not suitable for a drip system. Medium textured soils such as sandy loam, sandy clay, silty loam, clay loam etc. are best suited for drip irrigation practices.
- **Commitment to best management practices.** On the small scale, drip irrigation requires no extensive and complicated technicalities

in maintenance. The requirement for operation, management and maintenance increases with hectareage. For instance, water quality plays a crucial role in drip system efficiency and if the system is typically combined with fertilizer (fertigation), the level of technicality requires increases.

## 8.4 Investment Requirement

Drip irrigation comprises different components and can be applied at whatever scales – from the Bucket Drip and Family Drip Kits to large drip irrigation farms covering several hectares. Thus, investment depends on the scale of irrigation farms, instrumentations and other installations to improve the efficiency of the systems. For a smallholder system using the bucket drip and family drip kits covering about 100 – 500m<sup>2</sup>, the cost may range from US\$50 to US\$300 (FAO, 2014). This may not include the development of water sources i.e., the construction of well or pump installations and storage/reservoirs which usually have to be lifted 1-2m. Commercial drip systems are around US\$8 000–10 000/ha with energy costs estimated at US\$500–700/ha, thus the investment costs per hectare are substantial. The investment for a bucket or family drip irrigation system is considerable. Even though the costs of a bucket drip unit (US\$50) and a family drip unit (US\$300) are relatively modest, the area covered is quite small (50–250 m<sup>2</sup>). The labour costs to refill the bucket and water tank regularly are quite significant and estimated at US\$500–700/ha (FAO, 2014).

A major advantage of investing in a drip system is the water use efficiency and the certainty of high use of applied nutrients resulting in significantly improved water energy and economic productivity. As part of the planning and decision to invest, it is always expected that a good feasibility and market analysis must be carried out to ensure that the choice of crops to be irrigated will be able to pay back the investment over a reasonable period.

## 8.5 Design and Installations

### 8.5.1 Materials and Drip System Components

Depending on the scale of operation, some elements are required while



others are optional. However, every small-scale drip system has the following:



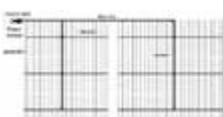

- Water source
- Elevated storage tank (1 – 2m) or pump system to maintain the system pressure (< 1.0 bar)
- Water supply mainline
- Lateral or drip lines
- Emitters/drippers
- End stoppers
- Valves (different types)

### *Pre-packed Drip Kits*

There are pre-packed small systems designed for predetermined land areas. Usually, the pre-packed/designed kits come with drip irrigation components/materials for the stipulated area e.g., 100m<sup>2</sup>, 250 m<sup>2</sup>; 500 m<sup>2</sup> or up to 2000 m<sup>2</sup>. Table 8.1 illustrates components of a drip irrigation system. The smallest of these pre-packed drip kits usually installed at areas about 100 – 250m<sup>2</sup> are described as the Family Drip System. When a drip system is planned for the area beyond these packages or more than 1 acre (4000m<sup>2</sup>), specific components may be required beyond what the manufacturers of the family drip systems offered in a typical pack. It must be noted, however, that some level of technical competency is required at this scale to appropriately design and couple these components together, develop a maintenance regime and ensure high efficiency of the system. Some of the irrigation equipment suppliers may also provide installation and after-sale services for installations in a larger area beyond the pre-packed systems.





**Table 8.1: Different components of a drip irrigation system**

| Components                     | Description and uses   | Pictures   |
|--------------------------------|--|--|
| <b>Basic components</b>        |  |  |
| Water source                   | Drip water sources can be from surface water, groundwater or pond. However, drip systems require high-quality water with no dissolved solids, turbidity, colour or salinity. pH should be neutral. |  |
| Elevated storage tank (1 – 2m) | Storage tank<br>- Drum (200lit)<br>- PVC tank (1000 – 5000litres)<br>Stand height of 1-2m (or up to 3m with tank height) can produce up to 0.2 – 0.3bar. Sufficient for a small area.              |    |
| Water supply mainline          | Water supply pipe from the tank or pump (for bigger systems). Size is determined based on field size water required  |    |
| Sub mainline                   | A secondary line from the main line. It feeds the lateral lines.   |  |
| Lateral or drip lines          | Lateral lines supply irrigation water to the field and carry the emitter/drippers.   |   |
| End stoppers/plug              | End stoppers are used to hold/plug the lateral lines at the end to disallow flow and allow for flushing when necessary.  |  |

| Components               | Description and uses   | Pictures  |
|--------------------------|--|---|
| Emitters/drippers        | Emitters or drippers are the units that dispense irrigation water. They may be inline in which the emitters are planted in the lateral hose or may be mounted. They can be pressure compensated or non-pressure compensated. Pressure compensated emitters are best for rough undulating terrains. They maintain the pressure and discharge irrespective of the slope. |    |
| In-line filters          | In-line filters are small size filters for screening dirt, sand and silts from a low scale drip system. They are very essential in the drip system. The capacity is limited and bigger filters are required for a large drip system.   |    |
| Connectors               | To connect laterals to the sub-mainline, different nipples, tees and other types of connectors are used. The use of these elements depends on the designs, land shapes and size of the irrigation system.  |   |
| Valves (different types) | Valves generally are devices used to control fluid flow. They come in different types and capacities.  |  |
| Check valve              | A check valve allows flow in one direction and automatically prevents backflow. They may be required in the head control.  |  |



| Components   | Description and uses  | Pictures   |
|--|---|--|
| Gate valve   | These types of valves are used to allow or completely disallow flow in a system rather than for changing the direction of flow.   |     |
| <b>Components for large system</b>                           |   |  |
| Pressure pump system to maintain up to 1-2 bar in the system | For large areas, a water pump is required to keep water flow and pressure in the drip system. This is critical when the pressure from the storage tank will not be adequate. The solar-powered electric pump is most preferred in drip irrigation. The capacity must be determined based on the field size and installations. |    |
| Pressure gauges  | A drip system is a low-pressure system. A pressure gauge is used to monitor the system pressure. It is an essential component in the drip system beyond the pre-packed family size drip kit.  |    |
| Pressure regulators  | The pressure regulator is used to keep the pressure in the system at a determined level.  |  |
| Water meter  | A water meter is used to measure the water flow in the system.  |  |

| Components                       | Description and uses  | Pictures   |
|----------------------------------|---|--|
| Filters tanks                    | Filters are installed to remove solids, sands, silts and algae from the water, especially for water from rivers, ponds or groundwater. There are different filters and the choice of a type depends on the peculiar need of the system. | <br> |
| Fertilizer/ Nutrient mixing tank | A fertilizer mixing tank is used to prepare fertilizer or nutrients for fertigation operation.  |   |
| Fertigation injectors or venturi | The venturi or fertilizer injector is required to ensure proportional application of dissolved nutrients during fertigation. These devices are in sizes and must match the system capacity, flow rate and pipe size.                    |   |

### 8.5.2 Drip Irrigation Installation

#### *Installing a pre-packed drip kit:*

These are a pre-designed set of drip irrigation components for a specific land area depending on the manufacturer or brand. There is no opportunity to expand after a specific package has been chosen.

#### *Pre-installation steps*

- Familiarize with the instruction or detail requirement for the chosen package. It is important to study the installation manual and ask your dealer/supplier questions about the package. For instance, is it an inline emitter system, do you have to install the emitters, the total length of laterals, emitter rate, recommended pressure or storage height etc.

- Clear and prepare your land. Make plant beds or ridges for your crops. The length of the beds is very important. Follow the lateral length and number of laterals recommended.
- Depending on the size/area of the package, follow the storage tank recommended and ensure that the stand to carry the water storage is properly put in place.
- Ensure that a good water source, clean and free of sediments or solids.
- Ensure a water-lifting device is in place. A small level (0.5hp) solar pump or another pump type may be used.
- In the case of a very small field, a bucket can be used for water lifting. This will, however, increase the labour required during irrigation.

### Installation steps

- Often, the installation of drip kits follows a plug and play procedure. In some instances, the supplier may also provide installation services and be part of the installation. However, in the case of a small home garden level:
- Unpack the package and follow the procedure in the manual.
- The basic steps for installation of pre-packed drip kits are stated below:

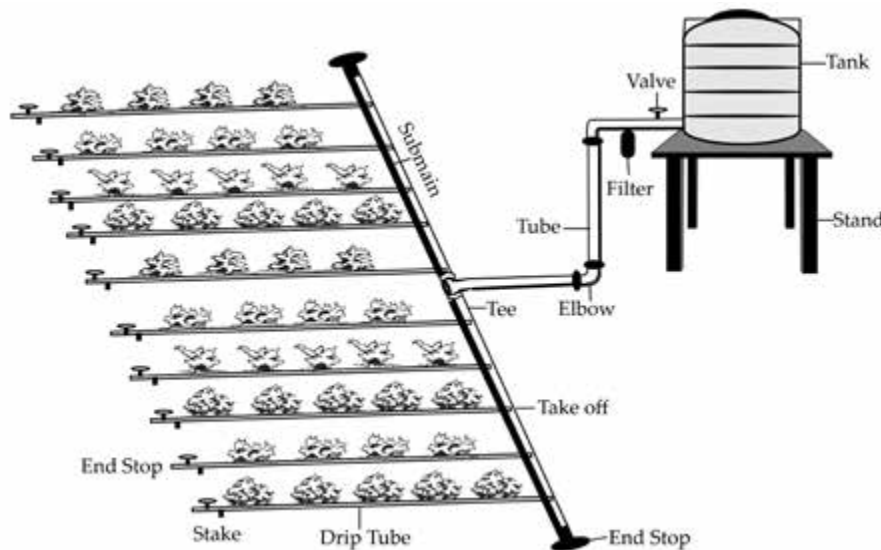

*Manufacturers produce Drip Kits in 100, 250, 500, 1000 and 2000m<sup>2</sup> or more. These pre-designed drip kits usually come with installations guide which is often explicit enough – following a do-it-yourself principle.*

Generally, consider the following steps:

#### Step 1:

- You may need some basic experience in plumbing or contact a local plumber.
- You will need a hack saw, knife or cutter, PVC or HDPE pipe length with diameter, elbow, tees and other fittings (of right sizes) provided in the package or recommended to be bought.

#### Step 2:

- Your field/ridge/bed must have been prepared as it is best suitable for your crop production.
- However, ensure your field crop spacing matches the lateral and emitter spacing recommended.

#### Step 3:

- Determine the position of your tank. It is better to have your tank in the upper slope side of the field.

#### Step 4:

Connect the various components in the following order

- Storage tank firmly secured in place on the stand/support structure.
- Connect the main valve to the tank.
- Connect the in-line filter, pressure regulator, timer (optional).
- Connect a union, elbow and Tee as may be required to lay the pipeline to the edge of your field.

**Step 5:**

Depending on the brand and the drip line provided, connect your laterals to the sub-main using an appropriate nipple connector and line valve.

**Step 6:**

- Conduct a test. Fill the tank with water.
- Open the tank valve and allow free flow in each of the laterals, one after the other.
- See that the laterals and the emitters are supplied with water.
- Flush the lines before putting the end stoppers.

**8.5.3 Installation of Drip System Beyond 1Acre**

For smallholder farmers who may wish to invest in drip irrigation beyond the pre-packed drip kits or above 1 acre, they will need to properly evaluate the field and design the system for efficient performance. It is highly recommended that the farmer consults a drip irrigation equipment supplier because of different options that may be possible, the intricacies involved and different bio-physical realities. A good vendor with the following services should be considered:

**CHECKLIST FOR AN  
IRRIGATION SERVICE  
PROVIDER**



- Capacity to assist with the evaluation of the economics and to ascertain that the idea of the farmer is worth the investment.
- Capacity for tailor-made design – appropriate irrigation solution to the investor’s business plan.
- Installation, operation and training services.
- After-sale and maintenance services.
- Set up a protocol for maintenance and best management practices.

Drip irrigation is an efficient system but requires technical details for implementation at a higher scale.

**8.6 Operation and Maintenance**

1. Ensure that good quality water is used for drip irrigation.
2. Periodic cleaning of the in-line filter is very important. The frequency of cleaning depends mainly on the quality of water.
3. Periodic flushing of the entire lateral lines to avoid clogging of the system.
4. Flushing is very important after the system has been used for fertigation operation.
5. Depending on the emitter type, ensure that the emitters are clean.
6. Be careful in the choice of fertilizer combination when the system is used for fertigation.

## Disclaimer

The mentioning of any equipment brand, illustrated or explained in this module is for training. The IWMI does not promote any brand of equipment and will not take responsibility for the choice of any brand.

## Acknowledgement

All the illustrations used in this manual have been appropriately cited. Any omission is hereby highly regretted. The photographs used in this manual are courtesy of IWMI.

## Bibliography

Food and Agricultural Organization. (1985). Irrigation Water Management: Irrigation Methods. Manual 5. Rome Italy.

Phocaides, A. (2007). *Handbook on Pressurized Irrigation Techniques*. Second Edition. Food And Agriculture Organization of The United Nations Rome, 2007

Quevenco, R. (2015). Bountiful crop with every drop: using drip irrigation to increase yields and conserve. Water IAEA Bulletin, March 2015



# MODULE 9

Irrigation Scheduling with  
FullStop™ Wetting Front Detectors



# Irrigation Scheduling with Fullstop™ Wetting Front Detectors

## 9.1 Introduction

The WFD provides a cost-effective method of assessing whether too much or too little irrigation water is being applied, to detect waterlogging and to monitor nutrient and salt levels in the soil. It comprises a specially shaped funnel, a filter and a mechanical float mechanism (Figure 9.1). The funnel is buried in the soil within the root zone of the crop. The indicator flag is fitted to an extension tube that protrudes above ground. When land is irrigated, water moves down as soil water holding capacity is exceeded. The funnel 'captures' water from the wetting front as it goes past. The water passes through a filter and is collected in a reservoir. If sufficient water is collected, it activates a float, which in turn pops up an indicator flag above the soil surface. The indicator pops up when the wetting front has moved about 10 cm below the rim of the funnel. The indicator flag is held up with a magnetic latch and must be pushed down to reset. An outlet tube at the base of the WFD allows water collected in the funnel to be extracted using a syringe and tested for salinity or nutrients. The WFD requires no power source, readers, loggers or software to operate.

The FullStop Wetting Front Detector (WFD) has been tested in South Africa, Zimbabwe, Mozambique and Tanzania (Stirzaker et al. 2017), Ghana (Adimassu et al., 2020) and Ethiopia (Schmitter et al., 2017; Tesema et al., 2016).

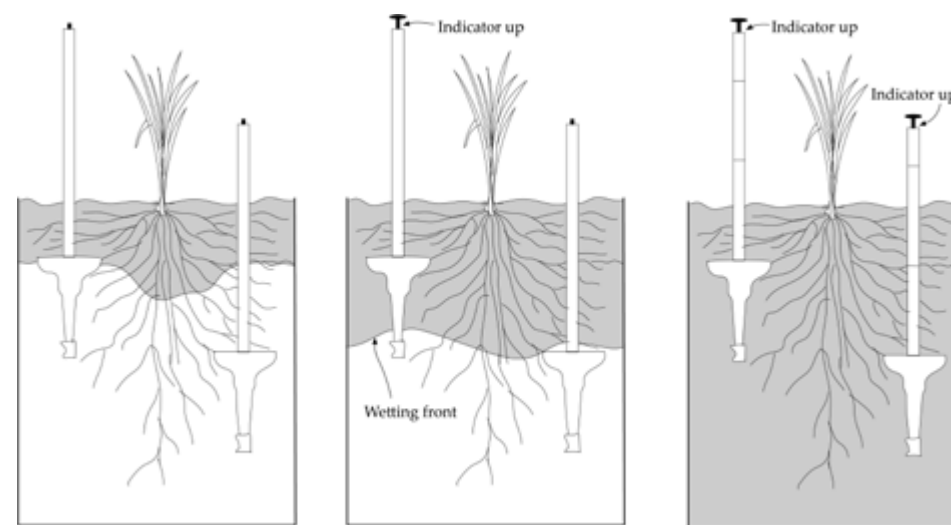

Figure 9.1: Typical use of wetting front detectors

## 9.2 Potential Benefits

The use of the WFD tool guides farmers on how much to irrigate without necessarily reducing crop yields. In areas where there is under-irrigation due to inadequate labour or energy, WFD help farmers to use the available labour or energy productively by guiding them to apply the required amount of water. Similarly, in areas where there is over-irrigation, WFD guides farmers to save water. Water productivity generally increases when the right amount of water is applied to crops. However, the effect of improved water management on yields varies among soil type, crop type and irrigation systems, and is also dependent on other factors such as the interaction with fertilizer and agronomic practices. Some research has been conducted on the effect of WFD on yield and water productivity. The impacts on water use and crop production depend on the crop, irrigation system, the labour involved, soil fertility and scheduling practices. Additional benefits include better quality of the products and a higher portion of marketable yields. Results from the evaluation of WFD in Ghana and Ethiopia are indicated in Table 9.1.



**Table 9.1. Effect of WFD on water use and yield**

| Crop    | Decrease in water use | Yield increase |
|---------|-----------------------|----------------|
| Onion   | 16 – 26%              | 4 – 21%        |
| Potato  | 19 – 43%              | 5 – 17%        |
| Tomato  | 21%                   | 14%            |
| Pepper  | 22 – 28%              | 14 – 75%       |
| Wheat   | 44%                   | -3%            |
| Cabbage | 5%                    | 13%            |

(Source: Schmitter et al, 2017)

### 9.3 Application Domains

WFD can be used in sprinkler, drip and furrow irrigation systems.

### 9.4 Investment Costs

A box contains two pairs of WFD and costs R 550 (USD 36.05) excluding freight charges and tax. It can be purchased at the VIA Shop Africa <https://shops.via.farm/>. A box contains red funnels (2), a base piece with steel mesh filter (2), black extension tubes (5), locking ring (2), indicator cap (2), foam floats (14), green flexible tubing (2), syringe (1) and a bag of filter sand (1). A pair of WFD strategically placed in a well-levelled field can help a farmer to learn about his/her irrigation requirements.



Figure 9.2: Components of WFD

### 9.5 Assembling the WFD

Before starting Step 1, practise joining the base to an extension tube. Always dip extension tubes and base pieces in very hot water to soften plastic before joining. Insert the base piece into the wide end of the extension tube by lining up the lugs, then pushing and twisting. The fitting will be in the locked position after a quarter of a turn clockwise. Undo this fitting and follow the steps below.

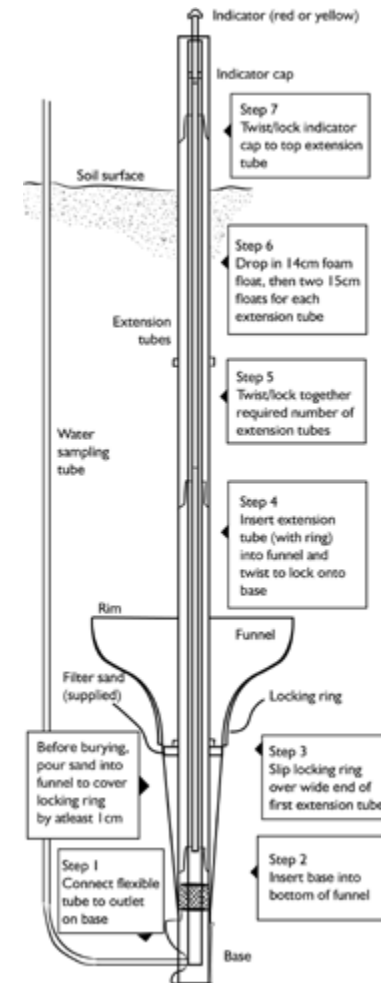

Figure 9.3. Installation steps

Step 1



Step 2



Step 3



Step 4



Step 5



Step 6



Step 7



#### Link to Assembling Video

<https://www.youtube.com/watch?v=RojPiPAXTKI&t=23s>

#### *Testing the Wfd for Leakages*

After assembling, there must be no leaks between the base piece and the funnel. Test each detector for leaks after it has been assembled by adding a syringe full of water into the funnel, with the flexible tube held upright to ensure water does not escape. The indicator will then rise and be held up by a magnet. No water should be visible at the joint between the funnel and the base. Let the water out via the flexible tube and tap the indicator down to release the magnetic 'latch'. The supplied filter sand must not be added until you are ready to install the detector. If there is the need to disassemble, remove floats first.

### 9.6 Depth of Placement of WFD

The optimum depth of placement depends on the irrigation method and the frequency of irrigation, as well as the type of crop and soil. Table 9.2 is given as a guide, based on our experience. Placement depths are measured from the soil surface to the locking ring. If measuring to the rim of the funnel, subtract 10 cm from the depths in the table. With experience, these recommendations can be adjusted for local conditions. In under furrow irrigation, place the WFD approximately at a 75% distance of the water intake for optimal wetting fronts.

**Table 9.2 Installation depth for different irrigation methods**

| Irrigation method | Notes   | Shallow detector | Deep detector |
|-------------------|---|------------------|---------------|
| Drip              | Amount applied per dripper is usually less than 6 litres at one time (e.g., row crops, pulsing) | 30 cm            | 45cm          |
|                   | Amount applied per dripper usually more than 6 litres at one time (perennial crops)             | 30 cm            | 50 cm         |
| Sprinkler         | Irrigation is usually less than 20 mm at one time (e.g., center pivot, micro-jets)              | 15 cm            | 30 cm         |
|                   | Irrigation is usually more than 20 mm at one time (e.g. sprinklers and draglines)               | 20 cm            | 30 cm         |
| Furrow / flood    | Deeper placements than shown needed for infrequent irrigations or very long furrow              | 20 cm            | 40 cm         |

When the float is in the up position, a wetting front has moved past the detector. The soil above the detector is as wet as it can be (almost saturated). That is why the above depths may appear to be shallow. A third detector, 10 cm below the deep detector depth shown above, can be installed if necessary.

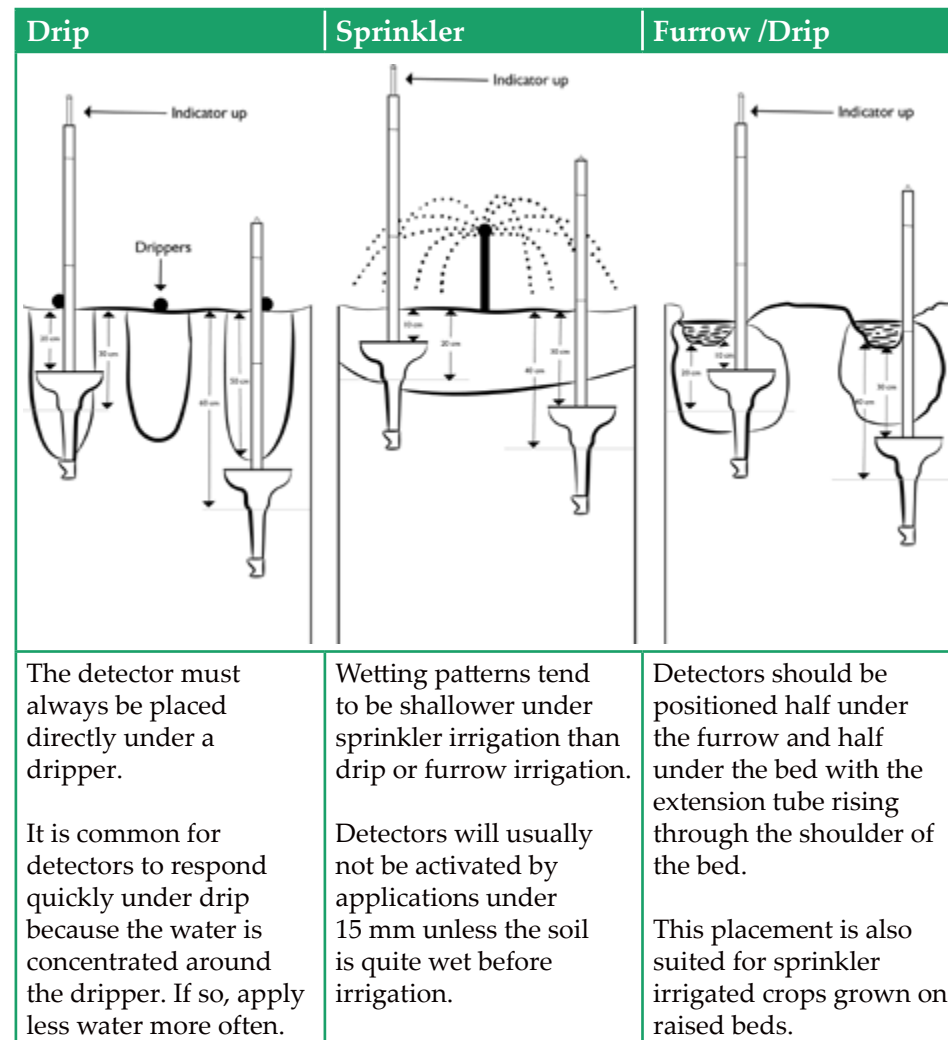

*Figure 9. 4: Depth of placement of WFDs*

### 9.7 Installation of WFD

#### Tools needed

- 20 cm and 5 – 10 cm augers (or shovel and trowel if you do not have access to the augers).
- Tape measure

|  |   |
|--|---|
|   |   |
| Auger  | Hand Trowel   |
|  |  |
| Shovel   | Measuring tape  |

### Installation steps

The following are instructions for installing the WFD using augers. A shovel can be used in place of the 20 cm auger and a trowel can be used in place of the 5 – 10 cm auger.

### Step 1 – Digging the hole



The detector is easiest to install using two augers: an auger (20 cm or larger in diameter) for the wide end of the detector funnel and another (5–10 cm in diameter) for the narrow end of the funnel. Alternatively, a spade and trowel can be used. Keep different soil layers separate when removing them from the hole if the soil type changes with depth. Installation is easiest when the soil is moist, rather than when it is very wet or dry.

### Step 2 – Add filter sand and insert it into the hole

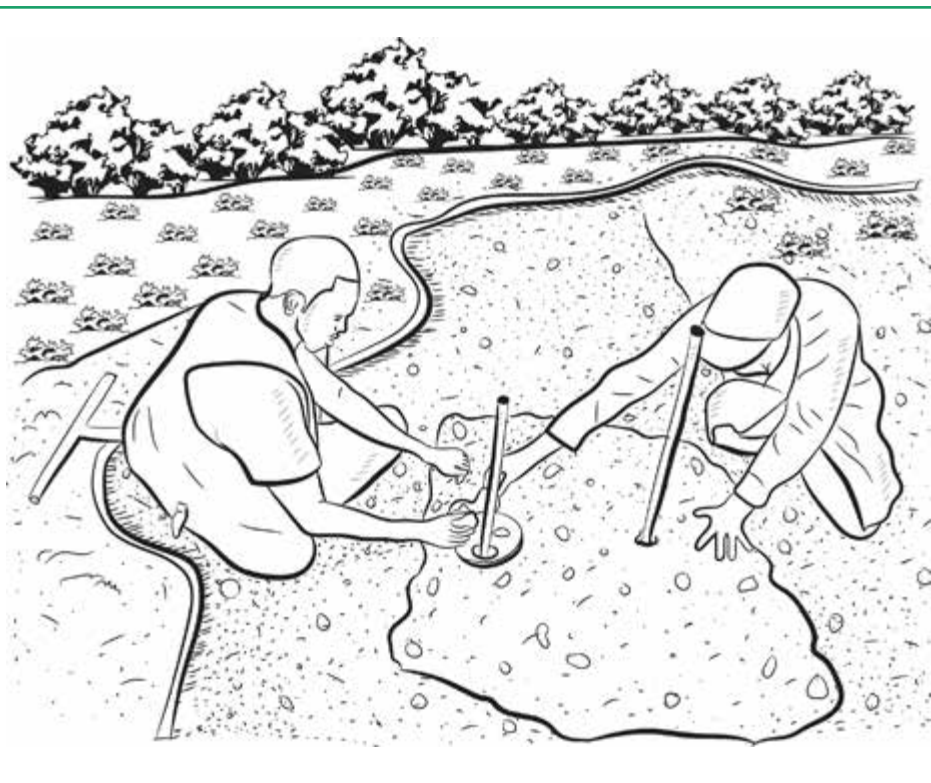

Pour the supplied filter sand into the funnel until it covers the locking ring by at least 1 cm. Lower the detector into the hole and measure the distance to the locking ring (or rim of the funnel) to check it is at the desired depth.

Holding the extension tube vertically upright in the hole, fill the funnel with the soil removed from the layer at the same depth and firm down lightly. Hold the flexible tube alongside the funnel up to the soil surface. Pack soil under and around the sides of the funnel until it is firmly in place as indicated in the diagram below. The deeper narrow hole does not need to be packed with soil.

### Step 3 – Bury the WFD



Break the sides of the hole as you return soil above the detector, as smooth sides may restrict the growth of roots and the movement of water. The hole must be filled by returning the removed soil to its original layer. Soil should be firmed down by hand but not compacted. All the soil should be returned to the hole leaving a slight hump over the installation. After settling, check to make sure the soil level over the installation site is the same as the surrounding soil so that water does not run towards or away from the FullStop detector.

**Step 4 –Activate the float**



Water the site over the detector after installation to trigger the float. This may require 20 litres or more for a deeper installation.

**9.8 Reading Soil Water Status**

When starting, the recommendation is that you continue to irrigate according to your normal practice while you get a ‘feel’ of how the detectors are responding. Then compare your normal practice to what the FullStop shows you as summarized in Table 9.3:

**Table 9.3. Interpretation of WFD indicator**

| Shallow Indicator | Deep Indicator | Meaning*   | Action  |
|-------------------|----------------|--|---|
| Down              | Down           | Insufficient water for established crops                         | Apply more water at one time or shorten the interval between two irrigations.   |
| Up                | Down           | Wetting front has penetrated the lower part of the root zone     | Most of the time, this is the desired result. During hot weather or when the crop is at a sensitive growth stage, the deep detector should respond. |
| Up                | Up             | The wetting front has moved to the bottom or below the root zone | If this happens regularly, then over-watering is likely. Reduce irrigation amounts or increase the time interval between irrigations.               |
| Down              | Up             | Soil or irrigation is not uniform or the soil surface is uneven  | Go through troubleshooting steps. Ensure the soil surface is level over the detectors. Check uniformity of irrigation or location of drippers.      |

\* This assumes that detectors have been placed at depths suited to the irrigation system and management regime

Once you have developed some confidence in the way the detectors are working, you are ready to improve irrigation, nutrient and salt management. Change your water use practice at the rate at which you are comfortable, taking into account the growth and/or yield response of the plants. Note that it is not necessary to get the desired detector response after each irrigation – the general trends are more important.

### 9.9 Monitoring Nutrients and Salt

Water trapped in the detector can be sucked out with a syringe via the flexible tube and monitored for its electrical conductivity or nutrient concentration (Figure 9.3). Samples should be taken soon after irrigation. Note that the detector retains a small sample of water after self-emptying. This should be removed prior to irrigations from which samples for nutrient analysis are required.

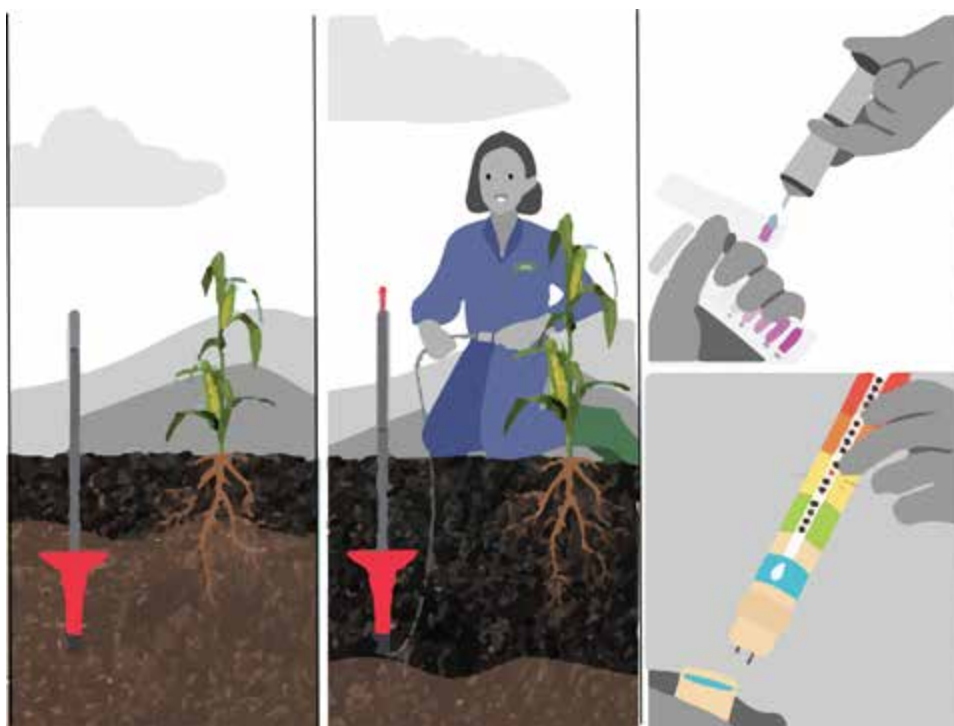

Figure 9.5 Monitoring nutrients and salts

### 9.10 Maintenance of WFDs

- Occasional testing and maintenance should be carried out to ensure that the detector is operating as expected.
- Ensure that there are no leaks before the installation. After installation, two further checks should be carried out every few months.
- Float mechanism: Inject 30 ml of water from the syringe into the green 4 mm tubing. The float should pop up.
- Filter: Irrigate till float pops up – then remove water from 4 mm tube with a syringe and reset float. The float should pop up again within 5 minutes.

### 9.11 Link to Installation Videos

Assembly video

<https://www.youtube.com/watch?v=5NMCdycR3LI>

Installation video

[https://www.youtube.com/watch?v=1p-cay\\_X3Kk&t=5s](https://www.youtube.com/watch?v=1p-cay_X3Kk&t=5s)

Measuring solutes

[https://www.youtube.com/watch?v=j\\_huHMa41eU](https://www.youtube.com/watch?v=j_huHMa41eU)

### 9.12 Limitations

The FullStop™ Wetting Front Detector has been designed to respond to 'strong' wetting fronts. In soil physics terms, the strength of the front must be around 2 to 3 kPa suction or wetter for the indicator to rise. In practice, this means that 'weak' fronts will not be detected and water can move past a detector without activating the indicator. Wetting fronts get weaker as they move deeper into the soil after the irrigation has been turned off. Weak fronts also occur during light rain, or when small amounts of water are applied at frequent intervals.



## Copyright

The Wetting Front Detector is a technology developed and owned by the Commonwealth Scientific and Industrial Research Organisation (CSIRO) Agriculture and Food and distributed in South Africa by RIEngs (Pty) Limited under licence from CSIRO Agriculture and Food.

## Disclaimer

Any decisions to change water use should be incremental and must be closely and regularly monitored to ascertain any negative impact on the crop. To the extent permitted by law, CSIRO accepts no liability arising directly or indirectly out of any misuse, negligent or incorrect use of the FullStop, any non-adherence to assembly or installation instructions or any circumstances outside CSIRO's control.

## Acknowledgement

All the illustrations used in this manual are courtesy of the Virtual Irrigation Academy (VIA), managed by [CSIRO Agriculture and Food](#) based in Canberra, Australia.

All the photographs used in this manual are courtesy of the International Water Management (IWMI) and Virtual Irrigation Academy (VIA).

The steps in the assembling and installation of WFD were culled from Virtual Irrigation Academy (VIA) (<https://via.farm/fullstop-instructions>)

## References

Adimassu, Z., Balana, B. B., Appoh, R. & Nartey, E. (2020). The use of the wetting front detector as an irrigation-scheduling tool for pepper production in the Upper East Region of Ghana: Evidence from a field experiment and farmers' perceptions. *Irrig. and Drain.* 2020;1–18. <https://doi.org/10.1002/ird.2454>

Schmitter, P., Hailelassie, A., Desalegn, Y., Chali, A., Langan, S. & Barron, J. (2017). *Improving on-farm water management by introducing wetting-front detector tools to smallholder farms in Ethiopia*. LIVES Working Paper 28. Nairobi, Kenya: International Livestock Research Institute (ILRI).

Stirzaker, R., Mbakwe, I. & Nuru, R. M. (2017). *A soil water and solute learning system for small-scale irrigators in Africa*. *International Journal of Water Resources Development*, 33:5, 788-803, DOI:10.1080/07900627.2017.1320981

Tesema, M., Schmitter, Petra, Nakawuka, Prossie; Tilahun, S. A., Steenhuis, T. & Langan, S. (2016). Evaluating irrigation technologies to improve crop and water productivity of onion in Dangishta watershed during the dry monsoon phase. Paper presented at the International Conference of the Advancement of Science and Technology, Bahir Dar, Ethiopia, 17-18 July 2016. 10p.

# MODULE 10

Irrigation Scheduling with  
Chameleon™ Soil Water Sensors



# Irrigation Scheduling with Chameleon™ Soil Water Sensors

## 10.1 Chameleon Soil Water Sensor

The Chameleon Soil Water Sensor is a simple electronic device used to monitor soil water levels in farmers' fields (Figures 1 and 2). It measures how moist the soil is under the plants and mimics the way plants experience (the tension required) extracting water from the soil medium. It is made up of sensors buried in the root zone and a Chameleon card or Wi-fi Reader. The Chameleon sensor is fabricated with an inner core of sensing material surrounded by an outer coating of gypsum. At the heart of the sensor is two gold-plated electrodes that measure the resistance across a special medium in the centre of the sensor. This special medium is packed into the sensor in such a way as to calibrate the sensor as it is built. Gypsum is then cast as an outer casing. The gypsum allows moisture to move through to the sensing material while dissolving a small amount of gypsum into the water, creating a constant electrical conductivity environment, thus buffering the sensor. When salt levels in the soil exceed 4 dS/m, the sensor calibration shifts.

The Chameleon Soil Water Sensor is designed to be accurate in the range that most irrigated crops are sensitive to water stress. It is designed to be easily installed, user friendly, and inexpensive. The sensors are buried in the root zone leaving the wire above ground to be connected to the Chameleon card. Alternatively, the sensor can be remotely connected to a Wi-fi Reader to read, store and send data. By using simple colour coding, farmers can make their own decision on whether to irrigate or not. Just like the famous multi-coloured reptile, the lights on the display change colour depending on how wet the soil is. All the farmer needs to do is simply connect the reader (Card Reader or Wi-fi Reader) to the sensor in the soil and get a reading for various depths in the profile.



Figure 10.1a. Chameleon Card starter kit



Figure 10.1b. Chameleon Card three sensor pack



Figure 10.2a. Chameleon Wi-Fi starter kit

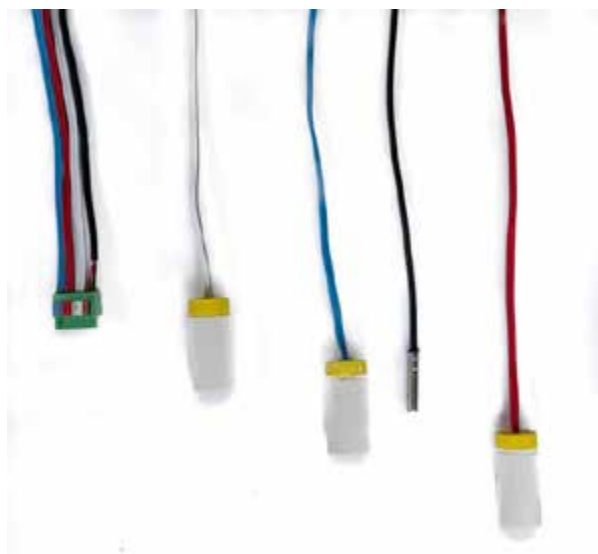

Figure 10.2b. Chameleon Wi-Fi Sensor Array

## 10.2 Potential Benefits

Over or under watering reduces crop productivity and reduces potential economic gains to be made from irrigation. For example, over-irrigation reduces the efficiency of fertilizers, increases fuel and labour costs and potentially results in low crop yields and, therefore, a reduction in income. It also leads to soil degradation, salinization and the potential occurrence of pests and diseases. By providing access to an inexpensive, easy-to-use and effective system to monitor soil water levels, farmers can positively adjust their irrigation regime resulting in the more sustainable use of water and improved yields. The use of Chameleon improves crop and water productivity. Improved labour productivity has been additionally reported with labour previously used for watering duties diverted towards other beneficial tasks such as weeding (<https://research.csiro.au/climatesmartagriculture/our-research/secure-food-systems/chameleon-sensor-and-the-virtual-irrigation-academy/>). Additional benefits include better quality of produce and a higher portion of marketable yields.

## 10.3 Application Domains

Chameleon is recommended for use with sprinkler, drip and furrow irrigation systems, especially where the farmer has control over the irrigation water. The Chameleon Sensor can be used in all soil types without calibration since it measures tension. It can be deployed in farmed irrigation systems as well as in communal irrigation schemes.

## 10.4 Investment Costs

A Chameleon Wi-Fi starter kit costs R 3,000 (USD 200) excluding freight charges and tax. The Wi-Fi starter kit consists of one Chameleon Soil Water Sensor Array and Chameleon Wi-Fi Reader. The sensor array consists of three Chameleon Sensors plus a temperature and identification sensor, connected to a terminal block. A Chameleon Card starter kit costs R 990.00 (USD 66) excluding freight charges and tax. The starter kit contains one Chameleon Card and three individual sensors (non-Wi-Fi version). Both the Chameleon Wi-Fi starter kit and Chameleon Card starter kit could be purchased at the VIA Shop Africa <https://shopsa.via.farm/>.

## 10.5 Depth of Placement of Sensors

Sensors can be placed at three depths in the same hole, e.g., at 20 cm, 40 cm and 60 cm. This allows you to see the progression of roots down into the soil through the growing season, as the colours turn from blue to green to red (see Figure 10.3). Multiple depths also let you see how deeply the water has penetrated after irrigation.

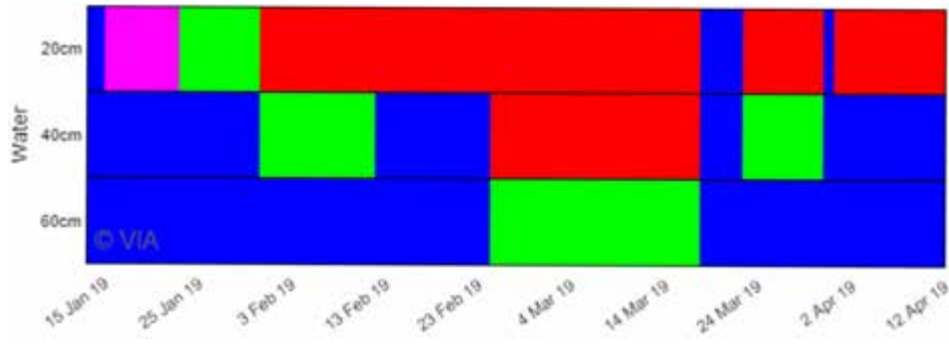

Figure 10.3. Example of changes in soil tension at three depths for an irrigated wheat field in Koga, Ethiopia in 2019 (source: Petra Schmitter / IWMI)

Alternatively, they can be installed at one depth at several different locations. Install a sensor in the middle of the root zone. For shallow-rooted crops, a single sensor may be placed at 10 to 20 cm depth. On the other hand, for deeper rooted crops, a single sensor may be placed at 20 to 30 cm depth. These depths represent the part of the root zone where most of the water is extracted. Sensors can be left in place for the next crop or removed at the end of the season and reinstalled.

## 10.6 Installation of Chameleon

### Making a sensor insertion tool

#### Tools needed

- 20mm diameter plastic or metal pipe approximately 50cm long
- File or angle grinder
- Permanent marker

### Steps

1. Cut a piece of 20mm diameter plastic or metal pipe approximately 50cm long.
2. With a file or angle grinder, sharpen the edges at one end.
3. With a permanent marker, mark depths along the pipe in 10cm increments.
4. Cut a piece of 13mm dowel approximately 60cm long.



Figure 10.4. Sharpened 20mm pipe and 13mm dowel (Source: Richard Stirzaker)

### Installing a sensor

The sensors are dry when packaged for shipment and too dry for the reader to detect them. Before use, soak sensors in water until they turn blue. It is worthwhile to conduct an irrigation uniformity test before installing sensors. Sensors located in dry or wet patches will not be representative of the entire field. This is particularly important for sprinklers. For drip irrigation, sensors should be placed halfway between the emitter and the edge of the wetting pattern. Locating the sensors directly under the drip emitter will shorten their lifespan.

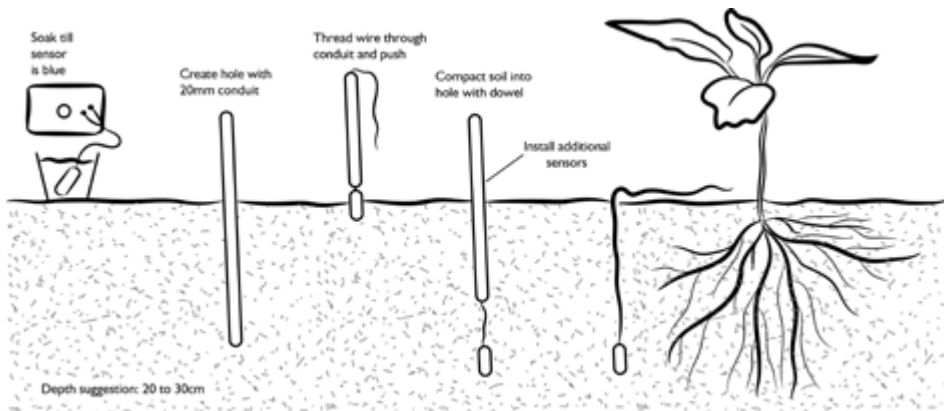

Figure 10.5. Installing single sensors

**Installation steps**



**Step 1** - Core a hole using a sharpened 20mm pipe. Use a smaller diameter dowel to unclog the pipe as you go.



**Step 2** - Feed the sensor wire through the pipe.



**Step 3** - Pull the wire firmly then insert it into the hole firmly until you feel the bottom.

**Step 4** - Backfill, using the pipe (or dowel) to compress the soil until the hole.

(Source: Pictures used to describe the installation steps are by courtesy Richard Stirzaker)

**10.7 Reading Soil Water Status**

The soil water status can be read with a Chameleon Card or Wi-Fi Reader.

**a. Chameleon Card**

The Chameleon Card (Figure 10.4) is a simple way to read soil water status from the soil water sensor. It reads one sensor at a time but does not store or upload data. The Chameleon card translates the resistance measured by the sensor into a colour code and displays the value using LED colours (Table 10.1).



Front

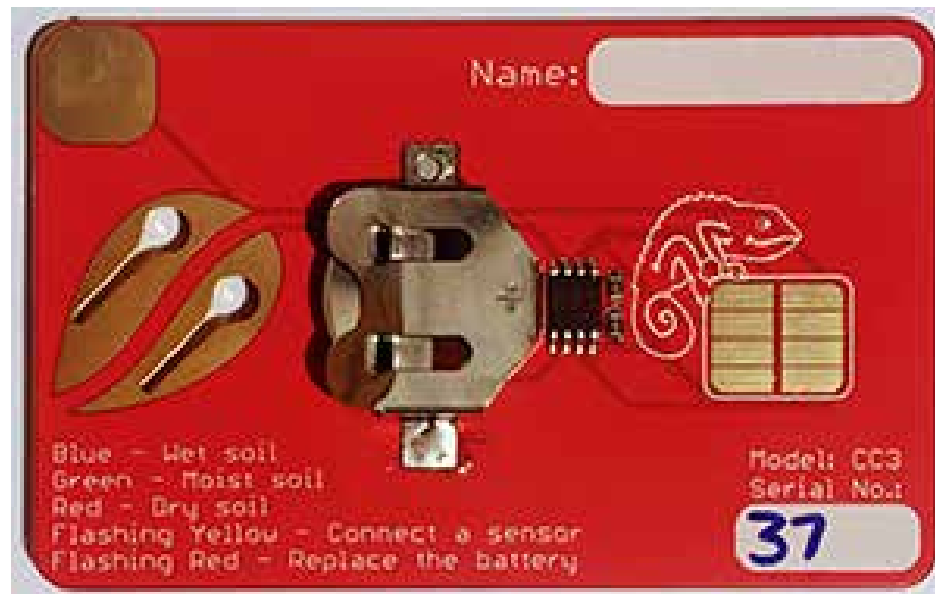

Back

To read the soil water status, a farmer needs to do the following.

1. Hold down the button.
2. Place the bare ends of the two wires of the sensor left above ground into the slots in the gold leaf.
3. The LED will display blue, green or red to show the soil water status.



Figure 10.7. Cameleon Card

#### Interpretation of the LED colours

The colour reflects how hard it is for a plant to extract water out of the soil. The colour shows farmers whether a particular soil depth is very wet (blue light – plants can easily attract water and potentially all pores are filled with water), too dry (red light - plants can hardly extract any water), or an adequate level (green light - plants can take up water) (Table 10.1 and Figure 10.6).



**Table 10.1. Interpretation of LED colours on Chameleon Card**

| LED colour      | Meaning                          |
|-----------------|----------------------------------|
| Blue            | Wet Soil                         |
| Green           | Moist soil                       |
| Red             | Dry soil                         |
| Flashing yellow | The sensor wire is not connected |
| Flashing red    | Battery needs replacement        |

The optimum time to irrigate most crops is when the Chameleon sensor reads green. When it reads blue, there is enough water in the soil unless the weather is extremely hot. When it reads red, the plant is already under some water stress. The simple rules above need to be interpreted for your particular situation. For example, you may not be able to get water whenever you need it, so you may decide to irrigate before the sensor turns green. Alternatively, the sensors may indicate red in the topsoil layer but blue in the middle and lower layers. If the roots are deep, irrigation can be delayed until more of the subsoil water has been used. Different crops are sensitive to water stress at different growth stages. For example, young maize plants can be slightly water-stressed at the early stages to ensure that the roots penetrate deep into the soil. However, the sensor must be blue during the pollination stage because the crop is now sensitive to water stress.

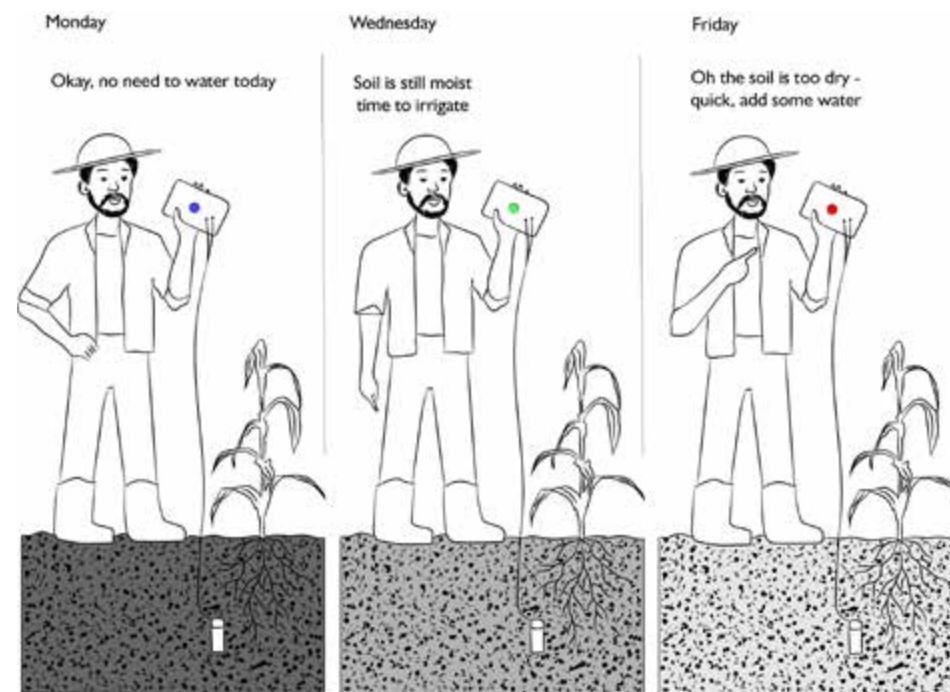

Figure 10.8. Interpretation of LED colours on Chameleon Card

#### Card maintenance

- Do not allow the Chameleon Card to get wet.
- If the sensor reads red with no wire connected, remove it from the cover, clean and dry the gold leaves with tissue on both sides.
- The battery should last for 1000 readings. When the LED flashes red, the battery needs to be replaced. Battery: Disposable CR2032 watch battery.

#### b. Chameleon Wi-Fi System

The Chameleon Wi-Fi System reads, stores and sends data to the VIA website platform. It is connected to a Chameleon sensor array. The sensor array consists of three soil water sensors placed in the top, middle and bottom of the root zone plus a temperature sensor which gives the array

a unique digital identifier. The Reader has three LEDs; one for each Chameleon sensor. The Chameleon Wi-Fi Reader can be permanently connected to a sensor array. In this case, it will log a reading every two hours. The Wi-Fi Reader can be paired to a Wi-Fi access point for continuous data delivery or a mobile phone for upload when visiting the crop. A Wi-Fi Reader can also be used to manually take and store data from many sensor arrays. This is an economical option when data is required less frequently (daily or weekly) from many different locations.

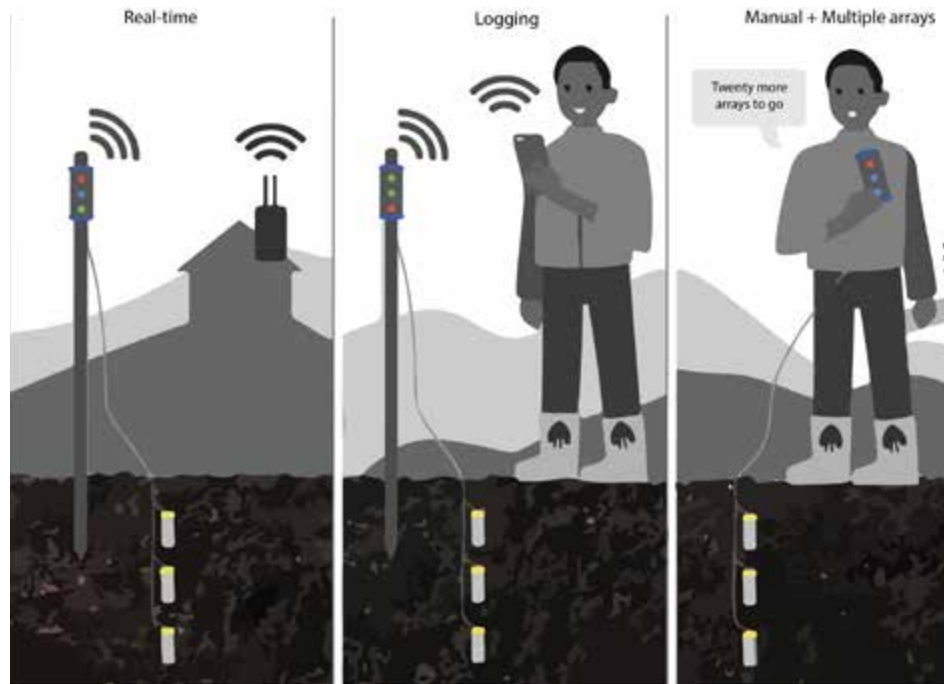

Figure 10.9. How the Chameleon Wi-Fi system communicates

### 10.8 Operation and Maintenance

Sensors give accurate readings for two to four years, depending on soil conditions. The lifespan can be shorter in very wet or salty conditions and where sensors are placed at shallow depth directly under drip emitters. This way, the calcium sulphate outer casing will dissolve more rapidly. If the sensor fails to turn blue after irrigation when it normally does, it's

time to replace it. The sensors slowly degrade over time with products harmless in soil. If the sensor is broken, avoid breathing dust from the sensing material from the inner core. The battery lasts for 1000 readings. When the LED flashes red, the battery needs to be replaced.

### 10.9 Link to Video on How The Chameleon Works

Chameleon uses in a garden

<https://www.youtube.com/watch?v=4470rERE87A>

Installation methods

[https://www.youtube.com/watch?v=6fn9VhA\\_pZc](https://www.youtube.com/watch?v=6fn9VhA_pZc)

Installing Chameleon Wi-Fi sensor array

<https://www.youtube.com/watch?v=qFR2rscCMs0>

Installing single Chameleon sensor

<https://www.youtube.com/watch?v=sNdw4-C-V7Q>

### 10.10 Link to Videos on Repair and Maintenance

<https://www.youtube.com/watch?v=F9oVp4TW85c>

### 10.11 Link to Videos of Success Stories

[https://www.youtube.com/watch?v=\\_CbIE6-R6fY](https://www.youtube.com/watch?v=_CbIE6-R6fY)

<https://www.youtube.com/watch?v=y91yh8d633M>

[https://www.youtube.com/watch?v=\\_nu3PS70pSM](https://www.youtube.com/watch?v=_nu3PS70pSM)

<https://www.youtube.com/watch?v=2LZVhG6X57w>

<https://www.youtube.com/watch?v=OlngqjMwdp4>

[https://www.youtube.com/watch?v=H6ENu\\_rrTw4](https://www.youtube.com/watch?v=H6ENu_rrTw4)

## Copyright

The Chameleon soil water sensor is a technology developed and owned by the Commonwealth Scientific and Industrial Research Organisation (CSIRO) Agriculture and Food and manufactured in South Africa by RIEng (Pty) Limited under licence from CSIRO Agriculture and Food.

## Disclaimer

Any decisions to change water use should be incremental and must be closely and regularly monitored to ascertain any negative impact on the crop. To the extent permitted by law, CSIRO accepts no liability arising directly or indirectly out of any misuse, negligent or incorrect use of the chameleon soil water sensor, any non-adherence to installation or reading instructions or any circumstances outside CSIRO's control.

## Acknowledgement

Unless otherwise specified, all the illustrations and photographs used in this manual are courtesy of the Virtual Irrigation Academy (VIA), managed by CSIRO Agriculture and Food based in Canberra, Australia.

The steps in the installation and reading of the chameleon soil water sensor were pulled from Virtual Irrigation Academy (VIA) (<https://via.farm/card/>).

## References

1. Chameleon Sensor and the Virtual Irrigation Academy. Climate-Smart Agriculture, Climate Smart Agriculture, 2019, <https://research.csiro.au/climatesmartagriculture/our-research/mitigation-and-adaptation/chameleon-sensor-and-the-virtual-irrigation-academy/>.

# MODULE 11

Contour Ridge Tillage / Farming



# Contour Ridge Tillage / Farming

## 11.1 Introduction

Contour ridge tillage/farming (CRT) is a holistic landscape levelling method for managing surface water in farmers' fields. Contour ridges are soil ridges constructed to run along the field contour to serve as barriers to the flow of runoff downslope (Figure 11.1). They slow down water flow to increase infiltration and trap sediments before they are washed away. One of the major challenges to the implementation of contour farming is the mapping or identification of the contours. The contour lines can be mapped out using topographic equipment such as automatic level, water level or an A-Frame. This module explains the basic use of Automatic Level and A-Frame for the mapping of contour lines and also itemizes the method of contour bund construction.

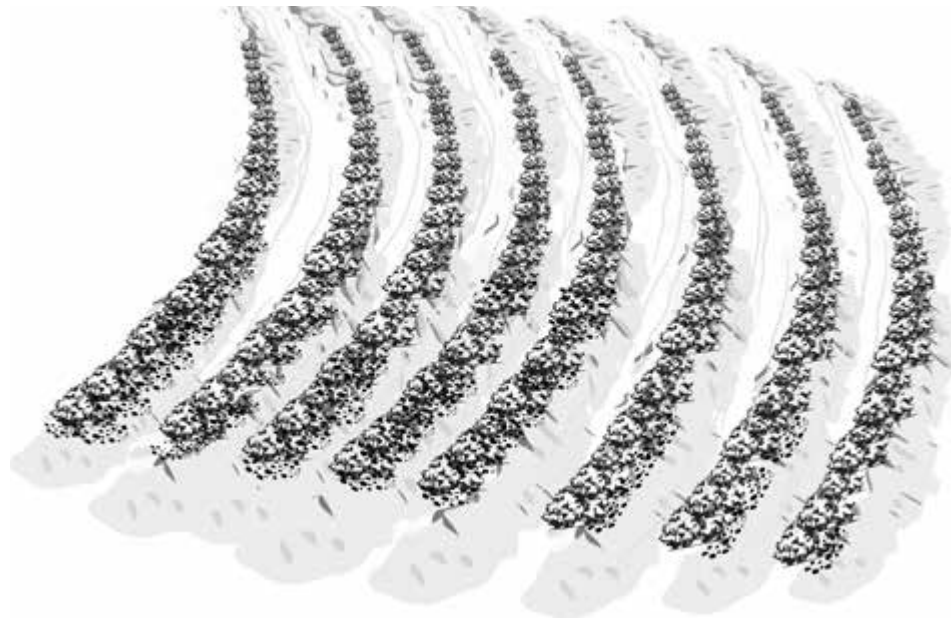

Figure 11.1: A contour ridge farm with permanent contour lines

A permanent contour ridge may be 100 cm wide and 20 to 50 cm high. Annual small ridges could be constructed along these permanent ridges. In certain areas, it may be necessary to add waterways to evacuate excess water off the fields (Conservation Agriculture Manual, 2005).

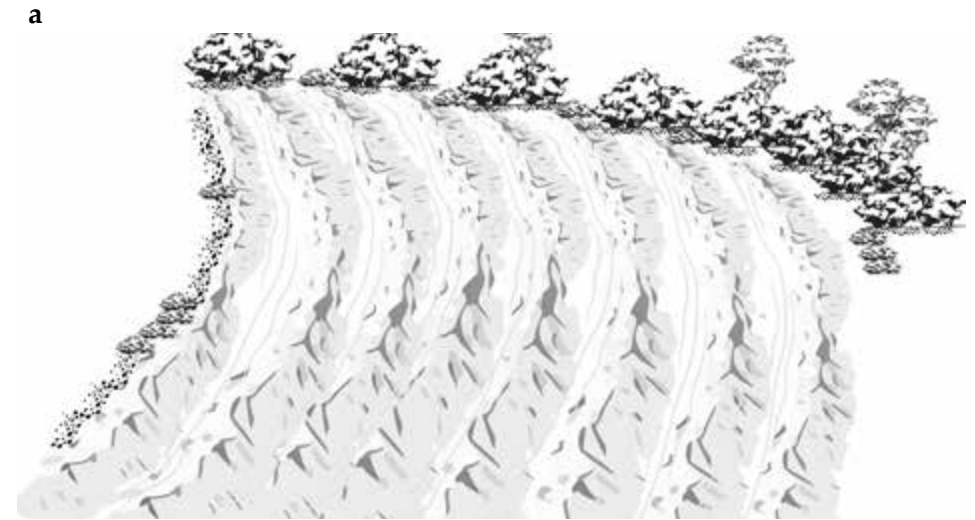

Figure 11.2: (a) Contour ridges (b) Contour ridges with crops growing on the ridges

### 11.2 Potential Benefits

Contour bunds/ridges are useful in retaining soil water and reducing erosion rates. This ensures that soil moisture is available for crop growth even in drylands (Figure 11.2). It is particularly beneficial in landscapes with high erosion potential. The use of contour bunds/ridges increases the grain and biomass yield of many crops (Traore et al., 2004; Traore et al., 2017; Traore & Birhanu, 2019; Birhanu et al., 2020). The effect of CRT on crop performances are visible from the first year of application of the technology. However, the effect on grain and biomass yield is dependent on the slope, crop type and agronomic practices. Results from a study conducted by Birhanu et al.(2020) on the effect of contour bunds/ridges on grain yield and biomass is presented in Table 11.1. Contour bunds/ridges can be combined with stone barriers to facilitate the spreading of runoff water.

**Table 11.1. Effect of contour bunds/ridges on grain yield and biomass**

| Crop      | Increase in grain yield | Increase in biomass |
|-----------|-------------------------|---------------------|
| Maize     | 63                      | 71                  |
| Sorghum   | 33                      | 42                  |
| Groundnut | 44                      | 42                  |
| Millet    | 78                      | 81                  |

Source: Birhanu et al. (2020)

### 11.3 Application Domains

Contour ridging is applicable in all farming landscapes. It is most useful in a dryland environment. It is widely used in the Sahelian and Sudanian ecology with rainfall varying from 250 to 1200 mm. For example, in Burkina Faso, Chad, Mali, Niger and Nigeria. The CRT is socially acceptable as a management strategy in fields where runoff may result in erosion.

### 11.4 Investment Costs

CRT involves the layout of contour lines with land levelling devices to identify points of equal elevation and the construction of contour lines with tractor or draught animals and human labour. The cost items are

the contour mapping devices (automatic level, water level or A-frame), measuring tapes, the hiring of tractor-mounted ridger or oxen-drawn plough, and human labour. Whereas automatic levels can be very expensive, an A-frame can easily be constructed with locally available materials. CRT may be more labour-intensive than under flatland cultivation. However, the initial high labour investment could be offset by labour savings later (for example through a decreased need for weeding).

### 11.5 Construction of Contour Ridges / Bunds

#### Tools needed

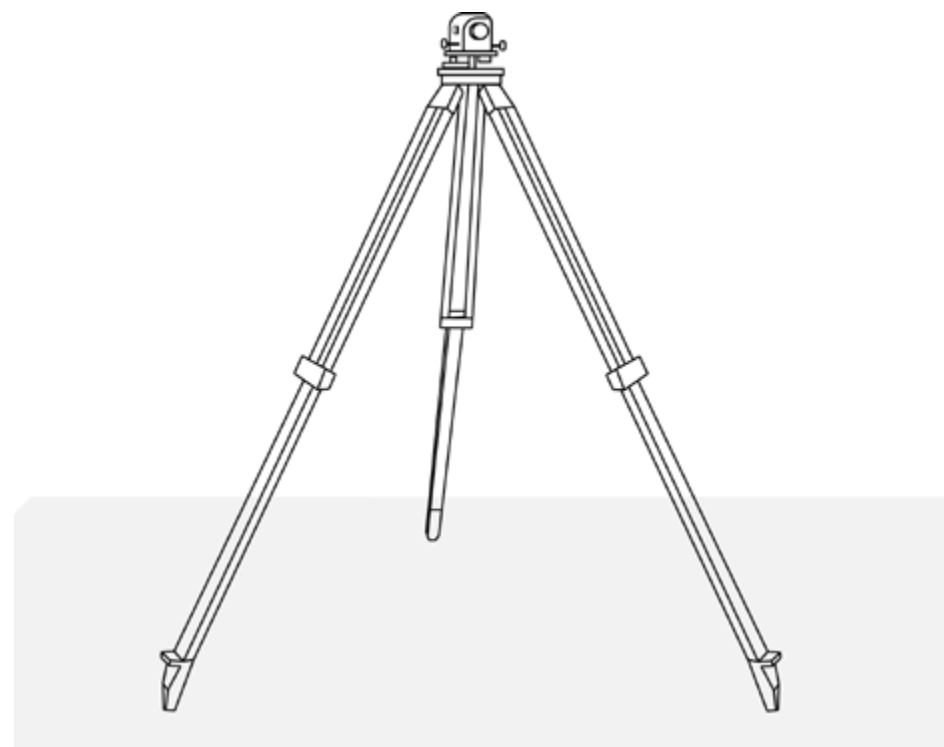

Automatic level

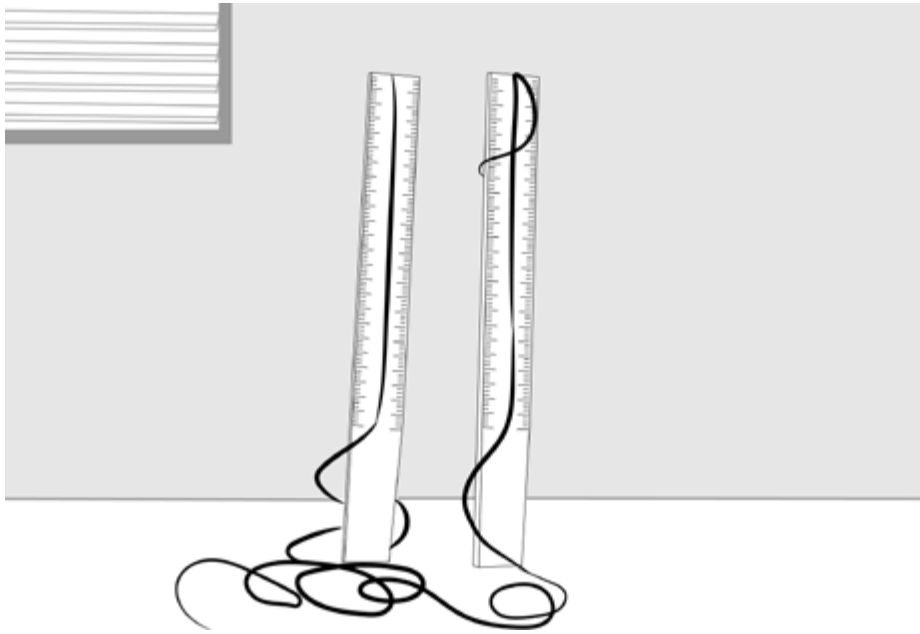

Water level

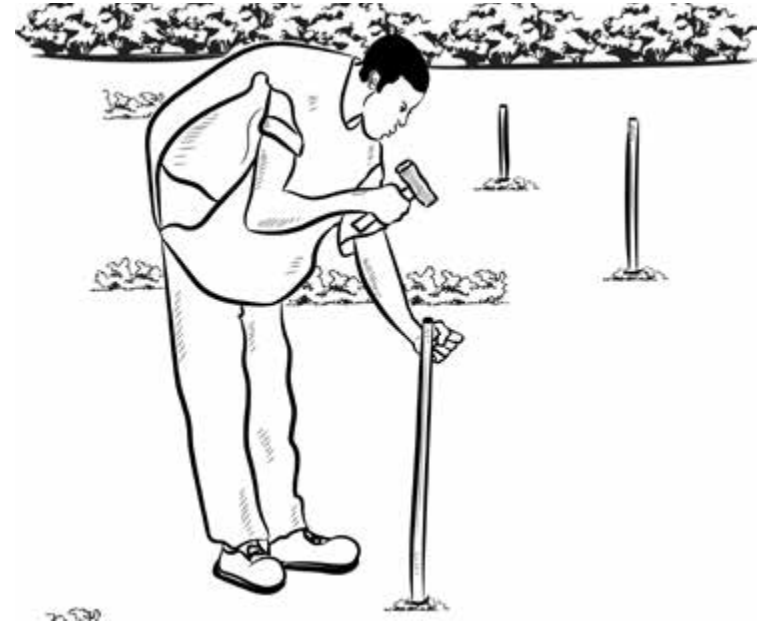

Pegs and hammer

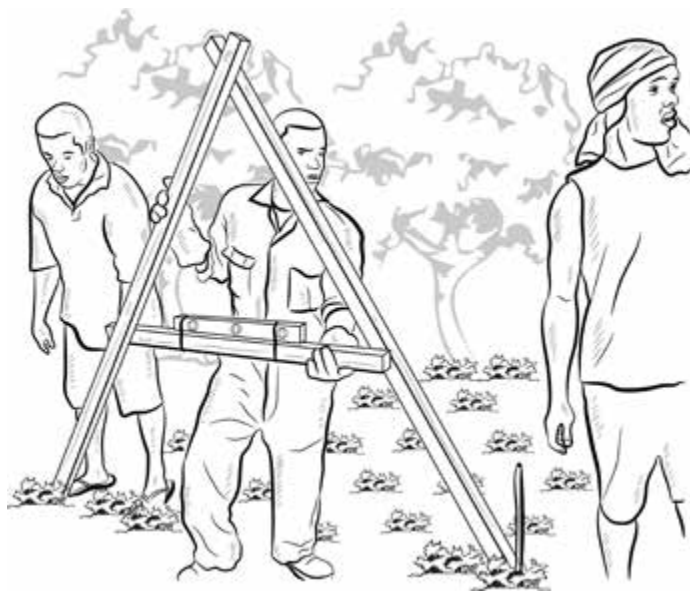

A-frame

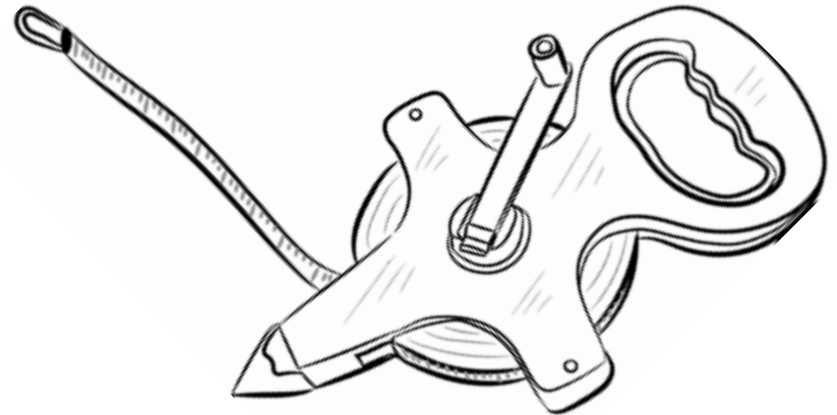

Measuring tape



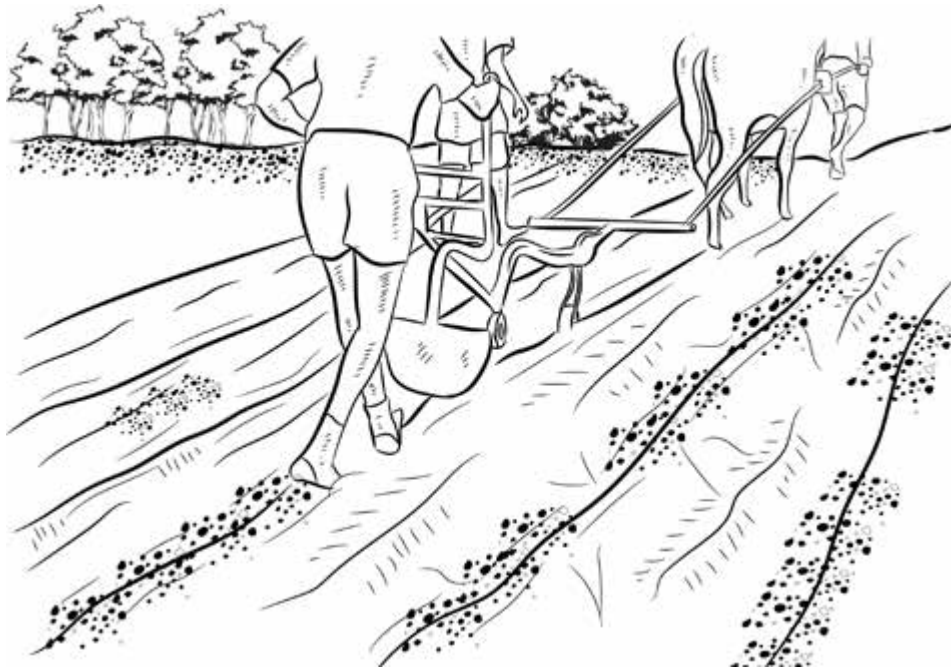

Plough or hoe

### Construction steps

#### Step 1: Field reconnaissance

- Explore the field to identify the extent of erosion, waterways, gullies, big trees, hills, etc. This can be accomplished through transect walks.

#### Step 2: Staking the contour ridge

- The contour ridge is determined using either an automatic level or A-Frame (Figure 11.4).
- Several sticks are driven into the ground using a hammer or piece of wood to map out the contour lines.
- Two methods of contour lines survey are usually used for the survey; Direct Method and Indirect Method.

#### i. Procedure for direct contour using automatic level

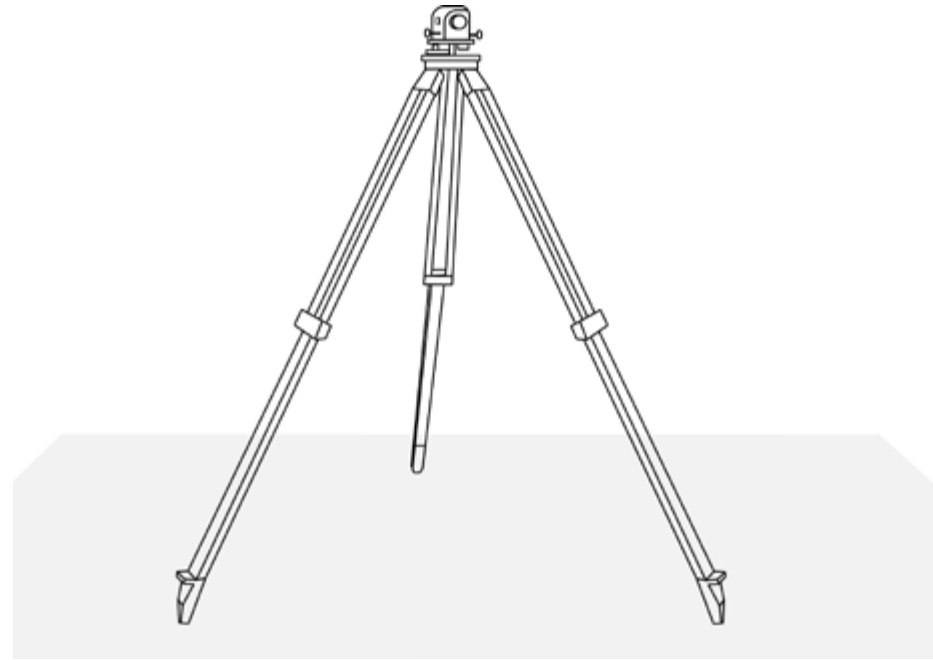

Figure 11.4: Automatic level positioned on a Bench Mark (BM)

- 1: Establish a temporary benchmark (B.M) in the area to be surveyed. With an automatic level, start the survey with reference to the permanent B.M by fly levelling.
- 2: The level is then positioned in a way that the maximum number of points can be commanded from the instrument station across the field.
- 3: The height of the instrument is determined by taking a back sight on the B.M. and adding it to the Reduced Level (R.L.) of the benchmark.
- 4: The staff reading required to fix points on the various contours is determined by subtracting the R.L. of each of the contours from the height of instrument.

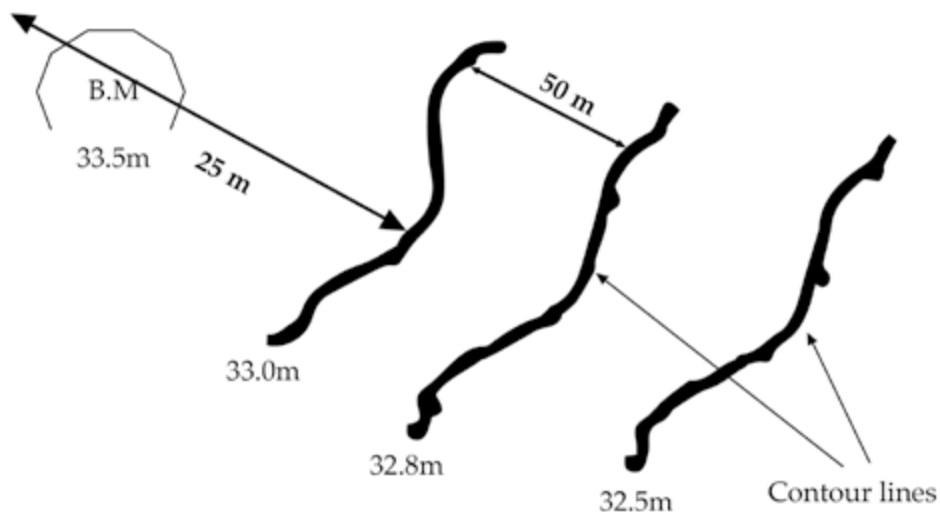

Figure 11.5: Using A-frame to map out contour lines

Example:

- With the instrument height of 33.5m at the BenchMark (BM), to locate contour lines 33.0m, 32.8m and 32.5m, the staff readings will be 0.50, 0.70 and 1.0m respectively.
- The positioning of survey staff is such that several other points can be located until the expected reading is obtained.
- The line joining all these points with the same reading gives the required contour.
- One contour is located at a time.
- Having fixed the contours within the range of the instrument, the level is shifted and set up in a new position.
- The contour lines are the path for the permanent ridges.
- The first contour line is usually implemented 25m from the limit of the field.

## ii. Procedure for direct contour using a-frame

1: Make an A-Frame.

- An A-frame consists of two wooden poles and a crossbar nailed together in the shape of a capital letter **A** with a base of about 90 cm. A carpenter's level is mounted on the crossbar (Figure 11.6).



Figure 11.6: Example of an A-Frame

2: Locate the contour lines using the A-Frame (Figure 11.6).

- One leg of the A-frame is put on the ground, then, the other leg is swung until the carpenter's level shows that both legs are touching the ground on the same level.
- A helper drives a peg beside the A-frame's rear (first) leg.

3: Continue to repeat the level-finding process

- The level finding process is repeated with stakes every 3m to 5m interval until one complete line is laid out, before starting another line.
- On steep slopes, the distance between adjacent permanent contour

lines should be about 3-5 m (Figure 11.7). However, this could be increased to up to about 50 m on very gentle slopes (1-2%).

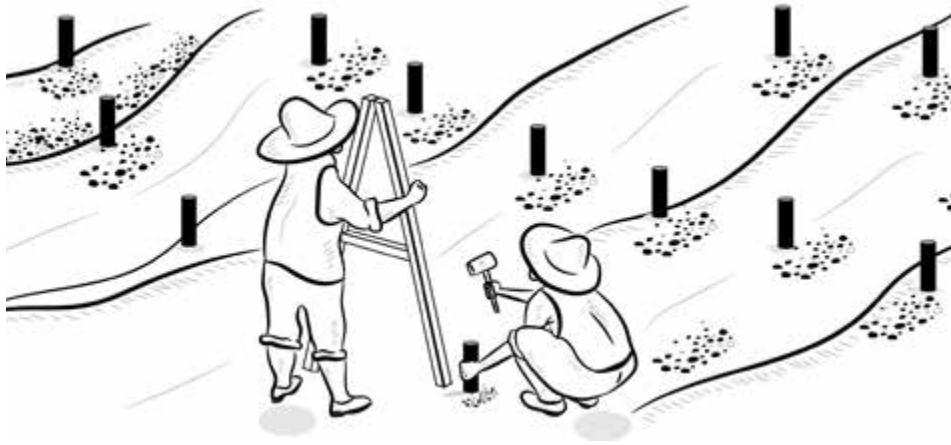

(Source: SWC, 1992)

Figure 11.7: Using A-frame to map out contour lines

### Step 3: Construction of the permanent contour ridge

- Make a ridge along the marked contour lines using a tractor-mounted ridger, oxen-drawn plough or hoe. The stakes will serve as a guide during the preparation of the ridges. The width of each ridge should be about one meter (Figure 11.8). The permanent ridge can be made bigger by 5-6 back and forth of an oxen plough.
- Make planting ridges in-between the permanent ridges.

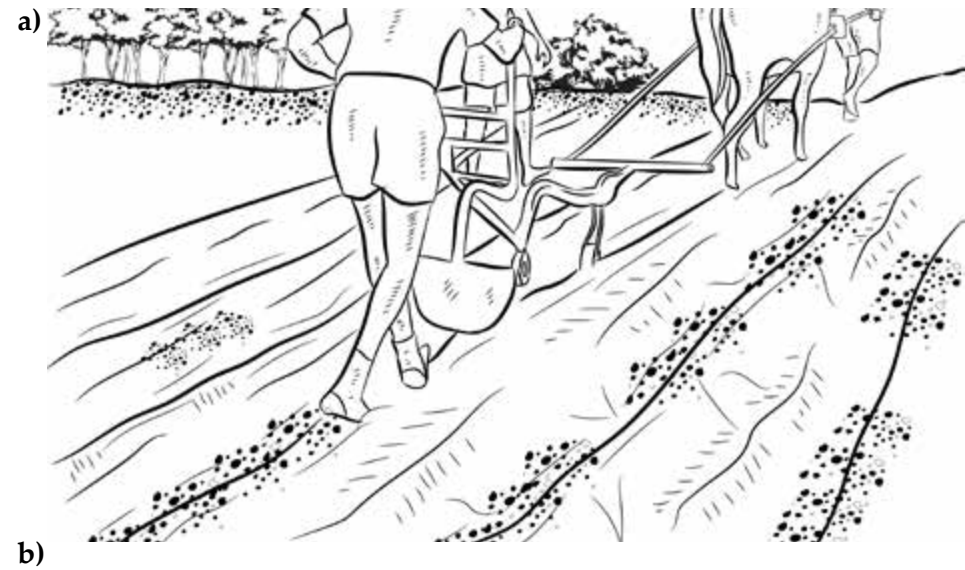

b)

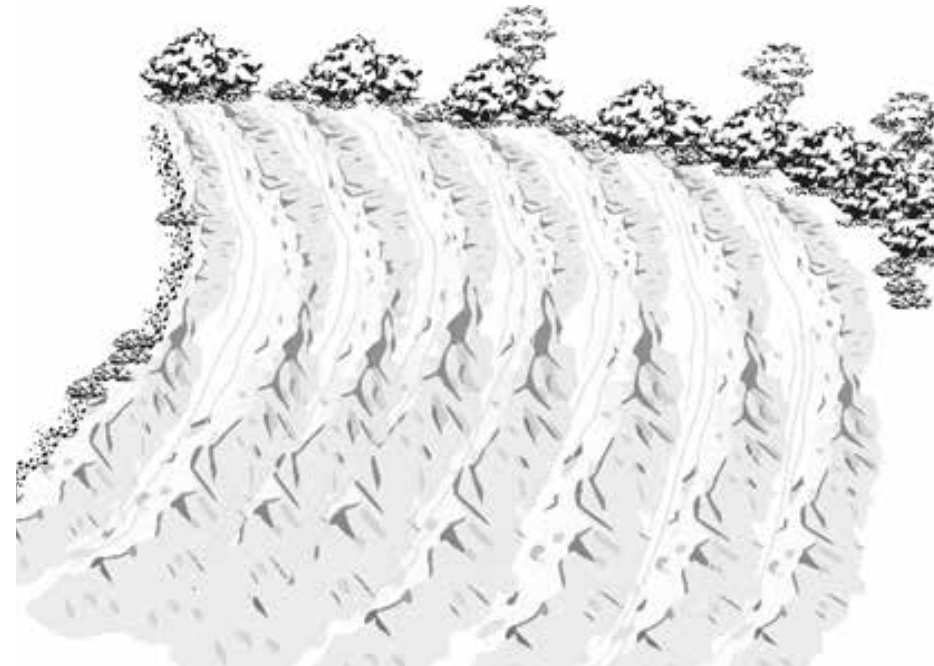

Figure 11.8. (a) Constructing a permanent ridge along the contour line (b) A field with contour ridges)

## 11.6 Maintenance of The Permanent Contour Ridge

Minimal maintenance is required if the ridges are properly constructed. Maintenance involves the reconstruction of any lines and ridges that might have collapsed due to heavy storms. Permanent ridges could be stabilized by planting grass or tree species on them. Once stabilized, the permanent ridges should not be cultivated (i.e., ploughed or tilled).

## Disclaimer

The mentioning of any equipment brand, illustrated or explained in this module is for the purpose of training. The IWMI does not promote any brand of equipment and will not take responsibility for the choice of any brand.

## Acknowledgement

All the illustrations used in this manual have been appropriately cited. Any omission is hereby highly regretted.

All the photographs used in this manual are courtesy of IWMI and Dr Khalifa Traore.

## Bibliography

Birhanu, B. Z., Traoré, K., Sanogo, K., Tabo, R., Fischer, G. & Whitbread, A. M. (2020). Contour bunding technology-evidence and experience in the semiarid region of southern Mali. *Renewable Agriculture and Food Systems*, 1–9. <https://doi.org/10.1017/S1742170519000450>

Conservation Agriculture Manual (2005). Conserving Soil and Water. *African Conservation Tillage Network*, 20. [www.act-africa.org](http://www.act-africa.org) (Accessed 10 January 2020)

Bekele, S. A., Lemperiere, P. & Tulu, T. (2009). *Training manual on agricultural water management*. IWMI (International Water Management Institute), Addis Ababa, Ethiopia, ILRI (International Livestock Research Institute), Nairobi, Kenya and Adama University, Adama, Ethiopia.

Soil and Water Conservation (SWC) 1992: Technologies and Agroforestry Systems. Agroforestry Technology Transfer (ATIK)

Traore, K. & Birhanu, B. Z. (2019). Soil Erosion Control and Moisture Conservation Using Contour Ridge Tillage in Bougouni and Koutiala, Southern Mali. *Journal of Environmental Protection*, 10, 1333-1360. DOI: 10.4236/jep.2019.1010079

Traore, K., Sidibe, D. K., Coulibaly, H. & Bayala, J. (2017). Optimizing yield of improved varieties of millet and sorghum under highly variable rainfall conditions using contour ridges in Cinzana, Mali. *Agriculture and Food Security*, 6:11. DOI 10.1186/s40066-016-0086-0.

Traoré, K. B., Gigou, J. S., Coulibaly, H. & Doumbia, M. D. (2004). Contoured ridge-tillage increases cereal yields and carbon sequestration - Conserving Soil and Water for Society: Sharing Solutions. *The 13th International Soil Conservation Organization Conference – Brisbane, July 2004* Paper No. 126 pages 1 – 6.

# MODULE 12

Laser Levelling – Engineered  
Surface for Irrigation



# Laser Levelling – Engineered Surface for Irrigation

## 12.1 Laser Levelling for Improving Surface Irrigation Efficiency

The unevenness of the soil surface can affect soil moisture distribution pattern, water-nutrient and crop root interactions which could affect crop germination, growth and yield. Land levelling is a precursor to good agronomic, soil and crop management practices. Resource conserving technologies perform better on well-levelled and laid-out fields. The problem of uneven field is more pronounced in the surface irrigation practices than in other irrigation systems which affect irrigation efficiency significantly. Farmers recognize this and, therefore, devote considerable attention and resources to levelling their fields properly. However, traditional methods of levelling land are not only cumbersome and time-consuming but more expensive with poor results – when the low output/tradition levelling cost is compared to high output/laser levelling cost.

In traditional practices, to ensure the best water level in the field, a considerable amount of water is wasted. It is common knowledge that most of the farmers apply irrigation water until all the parcels are fully wetted and covered with a thin sheet of water. The unevenness of fields leads to inefficient use of irrigation water and also delays tillage and crop establishment. Fields that are not level have uneven crop stands, increased weed burdens and uneven maturing of crops. All these factors tend to contribute to reducing yield and yield quality which reduce the potential income. Effective land levelling is meant to improve water-use efficiency and crop establishment, and reduce the irrigation time and effort required to manage crop growth and development.

This module is designed to explain the benefits of engineered land levelling in fields, particularly in surface irrigation and help develop the skills of service providers, farmers and operators in using laser technology to achieve a level field surface. It is also intended to enable the users to identify and understand the operations of the various components of a laser-controlled levelling system and how to conduct basic troubleshooting.

## 12.2 Benefits of Land Levelling

Studies have indicated that a significant (20-25%) amount of irrigation water is lost during its application at the farm due to poor farm designing and unevenness of the fields (Shiv et al. 2014). This problem is more pronounced in the case of rice fields. Effective land levelling reduces the workload in crop establishment and crop management and increases the yield and quality. Level land improves:

- Crop establishment
- Reduces weed problems
- Improves uniformity of crop maturity
- Decreases the time to complete other operations
- Reduces the amount of water required for crops

Research has shown a large increase in crop yield due to good field levelling.

**Table 12.1: Results of land levelling experiments conducted by CIAP in Cambodia between 1996 and 1999.**

| Year    | Rice yield (t/ha) |                   |
|---------|-------------------|-------------------|
|         | Levelled fields   | Unlevelled fields |
| 1996    | 3.40              | 2.67              |
| 1997    | 2.27              | 1.46              |
| 1998    | 2.72              | 2.36              |
| 1999    | 2.34              | 2.00              |
| Average | 2.72              | 2.19              |

(Source: CIAP, 2000)

### Observed advantages of land levelling in surface irrigation

- Land levelling increases yield. A large part of this increase is due to improved weed control. Improved field water coverage from better land levelling reduces weeds by up to 40%.
- Land levelling makes possible the use of larger fields. Larger fields



increase the farming area and consequently, improve operational efficiency.

- Levelling reduces the duration for planting, transplanting and direct seeding for other crops like rice. For instance, a possible reduction in labour by changing from transplanting to direct seeding in rice is approximately 30 person-days per hectare.
- It reduces the total water required to grow crops by at least 10%.

### Investment in land levelling

The initial cost of land levelling using contractors and machinery is high. The costs vary according to the topography, the shape of the field and the equipment used. Nevertheless, the overall benefits are many.

Studies over many sites have shown that the actual cost ranges from \$3 to \$5 per 10mm of soil moved per hectare (Owen, 2012). However:

- The initial cost of equipment may be high for smallholder farmers. There are contractors and service providers who undertake land levelling at cost/mm of the earth material moved.
- Contractors charge between \$30 and \$100 per hectare depending on the soil type and physical peculiarities of the field. However, as the sophistication of the equipment increases, so does the cost/hectare.
- A 2-meter drag bucket costs \$1,000 to manufacture locally. A laser-controlled system will cost between \$10,000 and \$43,500. However, using more sophisticated equipment increases the area that can be levelled each day.

Tables 12.2 and 12.3 show a cost comparison for land levelling per hectare using different equipment and the comparison of levelling with other land preparation as input in crop production.

**Table 12.2: The time and cost comparison for land levelling in Cambodia**

|                               | Animal levelling board | 2-wheel tractor blade | 4-wheel tractor |
|-------------------------------|------------------------|-----------------------|-----------------|
| Purchase price (\$)           | 500                    | 1000                  | 12000           |
| Time (days)                   | 12                     | 7                     | 0.5             |
| <b>Operating cost (\$/ha)</b> |                        |                       |                 |
| Labor                         | 15.0                   | 9.0                   | 2.5             |
| Fuel & Oil                    |                        | 22.00                 | 32.50           |
| Repairs                       |                        | 5.00                  | 7.50            |
| Pumping cost                  | 6.00                   | 6.00                  |                 |
| <b>Fixed cost (\$/ha)</b>     |                        |                       |                 |
| Depreciation cost             | 12.00                  | 4.00                  | 7.50            |
| Total cost                    | 33.00                  | 46.00                 | 50.00           |

(Source: Owen 2012)

**Table 12.3: The additional cost and financial benefit from land levelling**

| Year                             | 1   | 2  | 3  | 4   | 5   | 6   | 7   | 8   |
|----------------------------------|-----|----|----|-----|-----|-----|-----|-----|
| <b>Additional cost (\$/ha)</b>   |     |    |    |     |     |     |     |     |
| Levelling                        | 50  | 10 | 0  | 0   | 0   | 0   | 0   | 0   |
| Ploughing                        | 15  | 0  | 0  | 0   | 0   | 0   | 0   | 0   |
| Fertilizer                       | 13  | 6  | 0  | 0   | 0   | 0   | 0   | 0   |
| <b>Financial benefit (\$/ha)</b> |     |    |    |     |     |     |     |     |
| Grain yield                      | 53  | 53 | 53 | 53  | 53  | 53  | 53  | 53  |
| Reduction in weeding             | 8   | 8  | 8  | 8   | 8   | 8   | 8   | 8   |
| Cumulative cash flow             | -17 | 38 | 99 | 160 | 221 | 282 | 343 | 404 |

(Source: Owen 2012)

Although the initial cost of land levelling is an extra expense, a cash flow over years shows that financial benefits do result from land levelling.

A well-levelled land has an advantage for many years. If appropriate ploughing techniques are used, releveling the whole field should not be necessary for at least eight to ten years. Farmers are encouraged to plough from the centre of the field out rather than continuing to use the traditional technique of ploughing from the outside of the field into the centre. Measurements are taken in fields in the second and third years after the levelling has shown very little variation in surface topography. The levelness of the field is maintained after two crop seasons.

### 12.3 Basic Features of A Laser-Controlled Land Levelling System

The laser-controlled system requires a laser transmitter, a laser receiver, an electronic control panel and a twin solenoid hydraulic control valve. The laser transmitter transmits a laser beam, which is intercepted by the laser receiver mounted on the levelling bucket. The control panel mounted on the tractor interprets the signal from the receiver and opens or closes the hydraulic control valve, which will raise or lower the bucket.

#### 12.3.1 Laser Transmitter

- It is a self-adjusting device; it works with DC from a rechargeable battery (3.7 volts) or an external battery (12 volts).
- This device is tightly closed to protect the internal components (optical, electrical, mechanical etc.) from water, dust and other weather elements.
- The laser transmitter mounts on a tripod which allows the laser beam to sweep above the tractor unobstructed.
- With the plane of light above the field, several tractors can work from one transmitter.

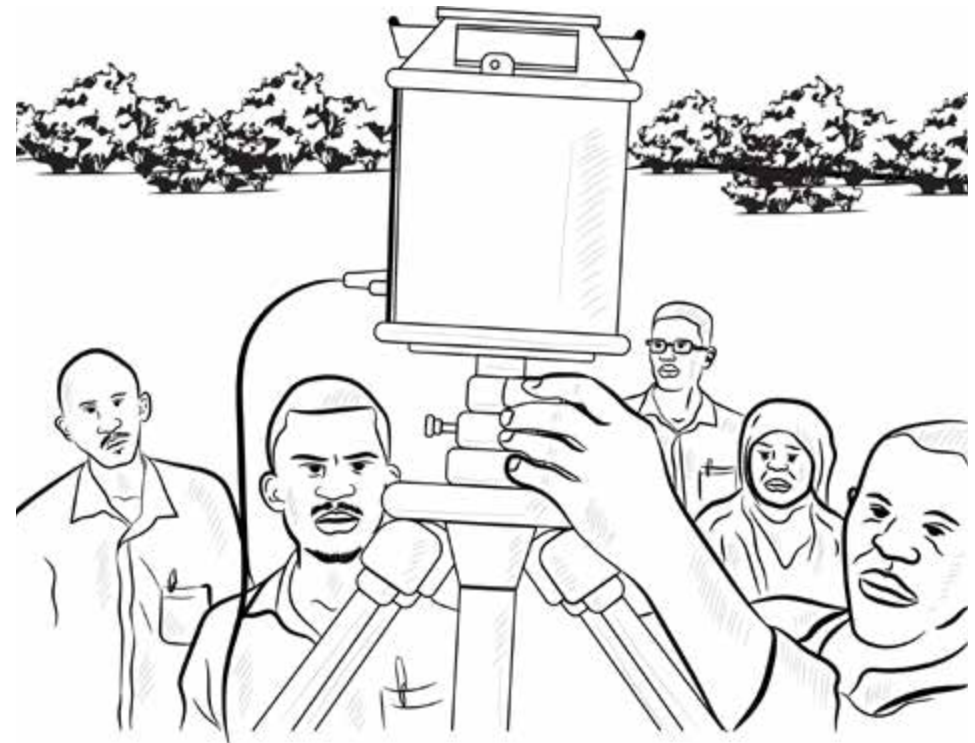

*Laser transmitter*

#### 12.3.2 Laser Receiver

- The laser receiver is an omnidirectional receiver that detects the position of the laser reference plane and transmits these signals to the control box.
- The receiver is mounted on a manual or electric mast attached to the drag bucket.

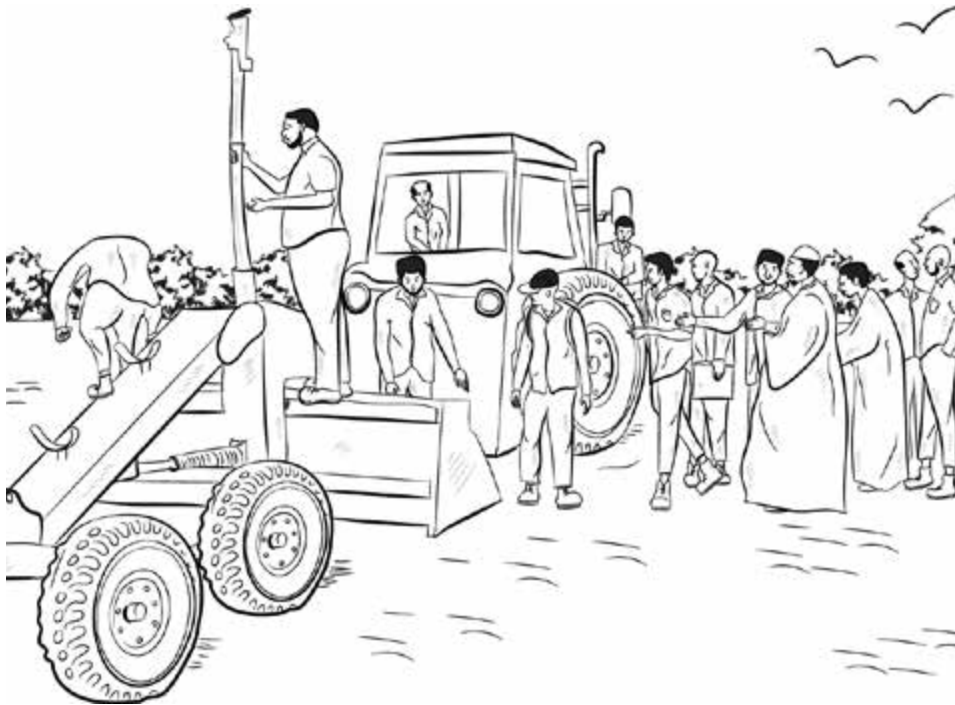

*Laser receiver*

### 12.3.3 Control Box

- The control box accepts and processes signals from the machine mounted receiver.
- It displays these signals to indicate the drag bucket's position relative to the finished grade.
- When the control box is set to automatic, it provides electrical output for driving the hydraulic valve.
- The control box mounts on the tractor within easy reach of the operator.
- The three control box switches are on/off, Auto/Manual, and Manual Raise/Lower (which allows the operator to manual raise or lower the drag bucket).

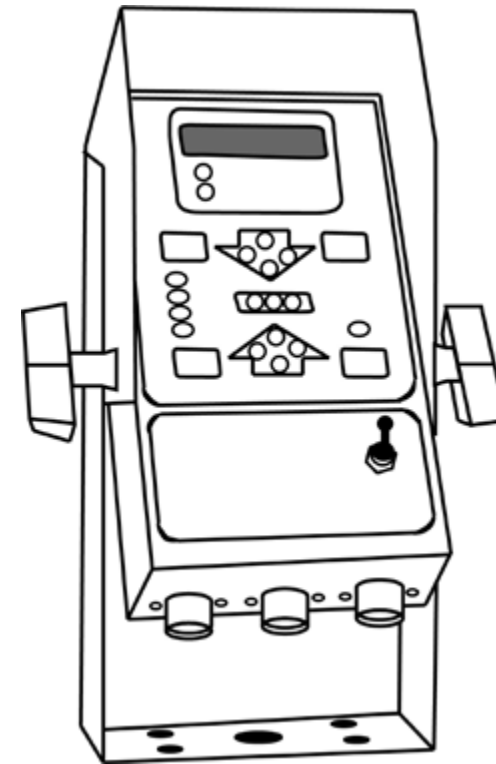

*A view of the control panel*  
(Source: <https://www.meilaser.com/Laser-Machine-Control-Products>)

### 12.3.4 Hydraulic Control System

The hydraulic system of the tractor is used to supply oil to raise and lower the levelling bucket. The oil supplied by the tractor's hydraulic pump is normally delivered at 2000-3000psi pressure. As the hydraulic pump is a positive displacement pump and always pumping more oil than required, a pressure relief valve is needed in the system to return the excess oil to the tractor reservoir. If this relief valve is not large enough or malfunctions, damage can be caused to the tractor hydraulic pump.

- Wherever possible it is advisable to use the external remote hydraulic system of the tractor as this system has a built-in relief valve that must

be fitted before the control valve. The solenoid control valve, when supplied by the laser manufacturers has a built-in relief valve.

- The solenoid control valve controls the flow of oil to the hydraulic ram which raises and lowers the bucket.
- The hydraulic ram can be connected as a single-acting ram; only one oil line is connected to the ram.
- An air breather is placed in the other connection of the ram to avoid dust contamination on the non-working side of the ram. In this configuration, the weight of the bucket is used for lowering.
- The desired rate at which the bucket raises and lowers will depend on the operating speed. The faster the ground speed, the faster the bucket will need to adjust.
- The rate at which the bucket will raise and lower is dependent on the amount of oil supplied to the delivery line. Where a remote relief valve is used before the control valve, the pressure setting on this valve will change the raise/lower speed.
- Laser manufacturer supplied control valves have pressure control adjustment on both the bypass relief valve and the raise and lower valves.
- When using a hydraulic ram, the ram should be positioned so that the ram body is connected in such a way as to push from the bucket frame rather than the depth control wheels.



*Hydraulic control system*

### **12.3.5 Laser-Level Land Requirements**

Laser levelling ensures that soil is shifted from the high points to the low points in the most cost-effective way. In most situations, fields will need to be ploughed and a topographic survey has to be undertaken before levelling commences.

### **12.3.6 Ploughing The Field**

Plough the field preferably from the centre of the field outwards. It is preferable to plough the field when the soil is moist because if the soil is ploughed dry, a significant increase in tractor power is required and large clod sizes may result. If the soil is very dry primary and secondary tillage operations are required, all surface residues need to be cut up or removed to aid soil flow from the bucket.

### **12.3.7 Topographic Survey**

Once the field is ploughed, you should conduct a topographic survey to record the high and low spots in the field. Other steps to follow:

- From the surveyed readings, you can then establish the mean height

of the field by taking the sum of all the readings and dividing by the number of readings taken.

- Then, using a field diagram and the mean height of the field, you can determine a strategy to effectively move soil from the high to low areas.
- Lasers are now widely used to accomplish a topographic survey.
- They are very accurate, simple to use and readily available in most countries. Recordings can be taken up to a radius of 300m from the transmitter.
- The laser surveying system is made up of a laser transmitter, a tripod, a measuring rod and a small laser receiver.
- A major advantage of laser surveying is the accuracy, simplicity of use and only one person is needed.

### 12.3.8 Other Equipment Required

Other equipment and materials needed when conducting a laser system for topographic surveying include:

- **Tape:** One 100-meter tape. White metal tapes are more accurate, fiberglass tapes are generally more robust.
- **Staff:** If a measuring rod is not available. The staff preferred a metric, upright with an E-type, pattern. Check the accuracy of the scale on the staff using steel tape because some staff faces may be out by one or more centimetres.
- **Compass:** If directions and bearings are to be recorded, a compass will be required. The compass can be used to set magnetic north on the level and allow recordings to be taken from it.
- **Pegs/hammer:** Pegs, preferably painted white, are required especially for marking out a grid survey or temporary marks.
- **Book:** A notebook is required to record all measurements and other information needed to make sense of the survey work completed in the field. Enough detail should be recorded so that the levels could be rechecked if necessary.

### Steps in laser topographic survey

- Open the tripod legs and adjust the individual positioning of the legs until the base plate is relatively level. Use the horizon as a visual guide to get the base plate level.
- Attach the laser transmitter to the base plate. If the laser is not self-levelling, adjust the individual screws on the base of the transmitter to get the bubble into the centre of both circles.
- Most lasers will not rotate unless the transmitter is level.
- Once the transmitter is level, attach the receiver to the staff and activate the sound monitor. The laser is now ready to commence recording heights.

### 12.4 Application Domain and Limitation

#### Land size

Laser levelling is more efficient for regular size and shaped fields.

#### Operation cost

The initial cost of land levelling using contractors and machinery is high. The costs vary according to the topography, the shape of the field and the equipment used. Once a field has been levelled, ploughing techniques must be changed to keep it level. Although the initial cost of land levelling is an extra expense, a cash flow over years shows that financial benefits do result from land levelling.

#### Training (e.g. farmers and operators)

Skilled operators are needed to set/adjust laser settings and operate the tractor. Therefore, training for farmers, contractors and government officials, demonstrations, field days and workshops for all the stakeholders should be organized.

### 12.5 Steps Required for Levelling The Field

Levelling a field involves the following steps:

1. The laser-controlled bucket should be positioned at a point that represents the mean height of the field.
2. The cutting blade should be set slightly above ground level.
3. The tractor should then be driven in a circular direction from the high

- areas to the lower areas in the field.
4. To maximize working efficiency, as soon as the bucket is near filled with soil, the operator should turn and drive towards the lower area. Similarly, as soon as the bucket is near empty, the tractor should be turned and driven back to the higher areas.
  5. When the whole field has been covered in this circular manner, the tractor and bucket should then do a final levelling pass in long runs from the high end of the field to the lower end.
  6. The field should then be re-surveyed to make sure that the desired level of precision has been attained.
  7. In wet areas where there is poor traction or a chance of bogging the tractor, care needs to be taken to fill the wet areas from the affected edge in a circular motion.
  8. If the fields are ploughed in lands and levelling undertaken in the areas of soil settlement in the second year, the fields should not require further major levelling works for at least 8 years.

### 12.5.1 Estimating Time Required for Cutting and Filling

The length of time taken to level the field can be calculated by knowing the average depth of cut from the cut/fill map, the dimensions of the field, the volume of soil that can be moved by the bucket and the tractor operating speed. The following example shows how to estimate the time required for cutting and filling.

#### Example 1: Estimating time length

| Variable                     | Calculation | Example      |
|------------------------------|-------------|--------------|
| Field dimensions (m)         | None        | 100m x 50m   |
| Average depth to be cut (cm) | None        | 25cm         |
| Levelling bucket dimensions  | None        | 2m x 1m x 1m |
| Bucket fill                  | None        | 50%          |

| Variable  | Calculation  | Example  |
|---|--|--|
| Tractor speed (average of speed when the bucket is full and empty in km/hr) | Calculated average   | 8km/hr or 8000m/hr                               |
| Volume of soil to be moved  | Field area/2 x average depth cut in meters (m)               | $100 \times 50 / 2 \times 0.25 = 625\text{m}^2$  |
| Volume of soil in the bucket ( $\text{m}^3$ )                               | Bucket dimensions x bucket fill                              | $2 \times 1 \times 1 \times 0.5 = 1\text{m}^3$   |
| Number of trips required  | Volume of soil to be moved x no. of trips                    | $625 / 1 \times 2$ (full and empty) = 1250 trips |
| Average trip length   | 50% of the field   | $100 / 2 \text{ m} = 50\text{m}$                 |
| Total distance travelled (m)  | No. of trips x average trip length distance (m)/speed (m/hr) | $1250 \times 50 = 62500\text{m}$                 |
|   | $62500 / 8000 = 7.77$ hours                                  |  |

In Example 1, approximately **8 hours** are required to level this field. This is an estimate which will vary according to the skill of the operator, the soil type and operating conditions.

### 12.5.2 Troubleshooting

| Problem   | Cause/Solution   |
|---|--|
| Bucket will not raise or lower                        | <ul style="list-style-type: none"> <li>▪ Check if the transmitter is working</li> <li>▪ Check hydraulic connections</li> <li>▪ Check electric connections on the solenoid</li> <li>▪ Check pressure relief valve setting on the control valve</li> <li>▪ Check for contamination in oil lines</li> </ul> |
| Bucket does not respond in certain parts of the field | <ul style="list-style-type: none"> <li>▪ Line of vision between transmitter and receiver blocked</li> <li>▪ Receiver as the same height as tractor cabin</li> <li>▪ Laser beam above or below the receiver height</li> </ul>   |
| The bucket will only move in one direction            | <ul style="list-style-type: none"> <li>▪ Check hydraulic connections</li> <li>▪ Check electric connections on the solenoid</li> <li>▪ Check pressure relief valve setting on the control valve</li> <li>▪ Check for contamination in oil lines</li> </ul>  |
| Bucket shudders when first started                    | <ul style="list-style-type: none"> <li>▪ Oil cold or no load in the bucket</li> <li>▪ Check pressure relief valve set</li> </ul>   |
| Bucket raises and falls automatically                 | <ul style="list-style-type: none"> <li>▪ Check line of vision</li> <li>▪ Check electronic connections on the solenoid</li> <li>▪ Check oil level in tractor hydraulic system</li> </ul>  |
| Field uneven  | <ul style="list-style-type: none"> <li>▪ Travelling too quickly</li> <li>▪ Raise and fall speed too slow</li> </ul>  |
| Field, not level or slopes the wrong way              | <ul style="list-style-type: none"> <li>▪ Check the levelness/calibration of the transmitter</li> <li>▪ Soil too compacted for the bucket to cut</li> </ul>   |
| Soil not flowing out of the bucket                    | <ul style="list-style-type: none"> <li>▪ Soil too wet</li> <li>▪ Too much foreign matter in the soil</li> </ul>  |
| Soil not flowing into the bucket                      | <ul style="list-style-type: none"> <li>▪ Too much crop/weed residue on the surface</li> <li>▪ Soil too compacted</li> </ul>  |

### More Information From

Laser Land Levelling animation (IRRI): Soil is Life YouTube channel: <https://www.youtube.com/watch?v=kRAwyr6oK7Q>(Accessed December 5, 2020)

### Disclaimer

The mentioning of any equipment brand, illustrated or explained in this module is for the purpose of training. The IWMI does not promote any brand of equipment and will not take responsibility for the choice of any brand.

### Acknowledgement

All the illustrations used in this manual have been appropriately cited. Any omission is hereby highly regretted.

The Laser Land Levelling Animation Video is from the International Rice Research Institute. The Soil is Life YouTube channel is acknowledged.

All the photographs used in this manual are courtesy Dr. Bashir Ahmed.

### Bibliography

Shiv, K. L., Harminder, S. S. & Manpreet, S. (2014). *Laser-Guided Land Leveling and Grading for Precision Farming*, Punjab Agricultural University, Ludhiana.

CIAP (2000). Annual Research Report, 1999. Cambodia-IRRI-Australia Project, Phnom Penh.

Owen, W. (2012). *Land Leveling – Techniques and Benefit*. Proceedings: Asian Irrigation Forum, 11-13 April 2012, Manila, Philippines.

# MODULE 13

Soil Moisture Conservation Techniques





# Soil Moisture Conservation Techniques

## 13.1 In-Situ Water Harvesting for Soil Moisture Conservation

Plants need adequate soil moisture throughout the active growing period since soil moisture is critical for plant physiological development and nutrient uptake. In rainfed cropping systems, there are periods when soil moisture becomes inadequate either because there is a drought - when rain is not adequate to meet the plant water need - or there is an unexpected cessation of rain much earlier than usual. This is a major challenge in dry ecologies. Even within these ecologies, where average annual rainfall is less than 900mm, a sizeable percentage of the rain is also lost through runoff. With water conservation techniques, more water could be made available for crop development. Many in-situ water harvesting techniques are effective in improving soil moisture. These techniques, when properly implemented, reduce runoff within the upland area. They are efficient in improving water retention, infiltration and thereby increasing available soil moisture for crop development. Although many of these techniques could be used in different terrains, they must be selected based on the peculiarities of the specific field. This module discusses few of these in-situ soil moisture conservation techniques. It also outlines the basics of how they can be implemented in the field.

## 13.2 Soil Moisture Conservation Techniques

In-situ water conservation techniques essentially are about creating a means by which rainwater is retained to increase available time for water infiltration. This enables the filling of soil pores making water available for crop beyond the period when there is rain. These techniques also reduce soil erosion since they curtail the erosive power of runoff in the field. Especially, in places with mild to steep slope, soil water conservation techniques can significantly help to reduce soil loss. There are many of such techniques. These include:

- Contour bunds or ridging
- Tied ridge and furrows

- Stone lines
- Half-moon micro-catchment
- Planting pits (Zai)

These technologies can also be combined to improve their effectiveness. For instance, half-moon micro-catchments or planting pits can be made within an established contour bund.

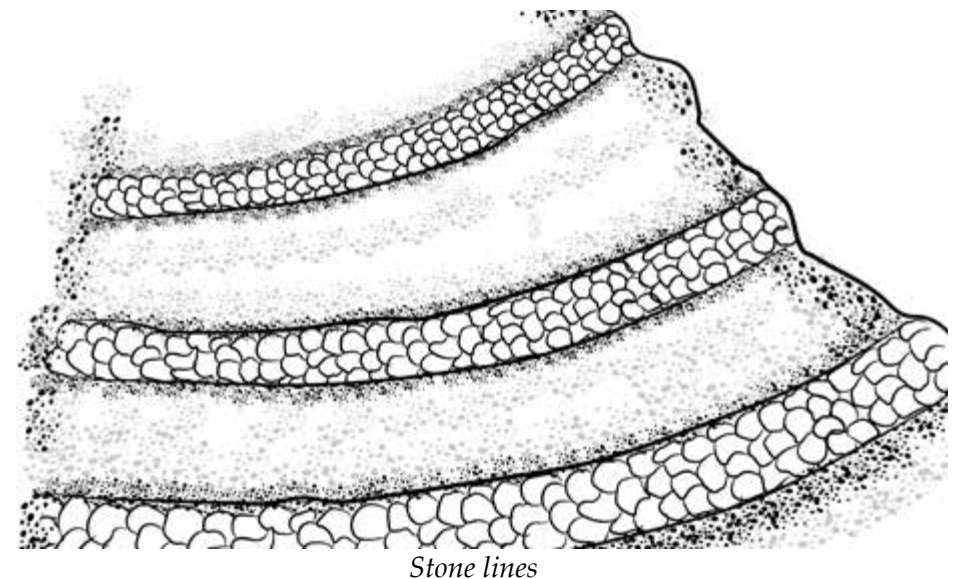
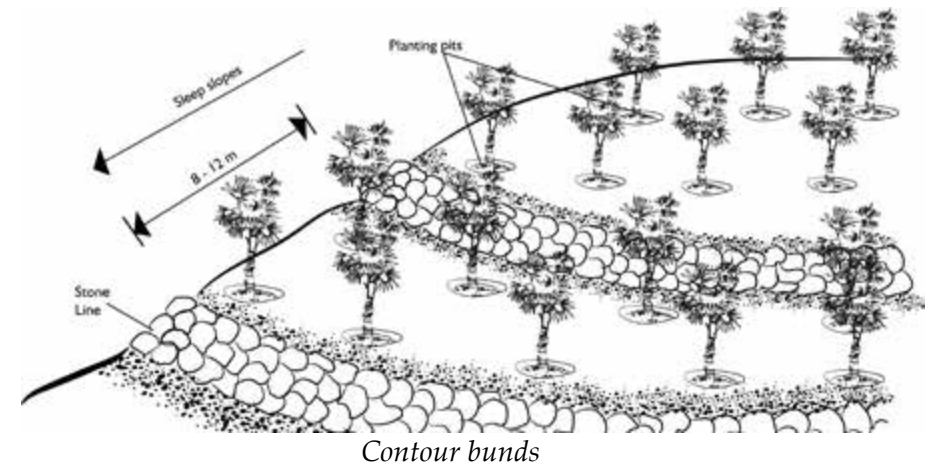



*Zai – Planting pits with millets*

### 13.3 Potential Benefits

The in-situ water harvesting and soil moisture conservation techniques have many benefits within the production landscape. The bund or stone line barriers created across the slopes along the contour lines directly limit the runoff flow. These measures have been known to reduce the erosive power of runoff and limit the volume of soil that can be transported from the soil surface. This is most beneficial in terrains with a steep slope and intense rainfall. When detached soil is trapped within the basins/barriers created by the bunds, tied ridges or pits, less nutrient is removed from the field. Most of the measures ensure that rainwater is retained for a longer period within the created barrier or enclosures. This allows water to infiltrate for a longer period. The filling of soil pores becomes a type of storage for plant roots. Some soil moisture conservation measures like mulching significantly reduce soil evaporation. This reduces the rate of soil dryness even in a dry environment. A combination of these measures may increase the benefits.

### 13.4 Descriptions and Application Domain

The in-situ water conservation techniques are applicable in most ecologies. This manual describes four (4) major types. These water conservation techniques take advantage of the contour of the field. The water flow along the major slope is retained by either of these techniques when implemented across the slope. The effectiveness depends on the physical characteristics in the field. These characteristics are described as necessary conditions as highlighted below. The African Conservation Tillage Network and International Water Management Institute's manuals – Conservation Agriculture (2005) and Seleshi et al. (2009) respectively – are good references for these practices.

#### 1. Contour bunds and ridges

Following the major slope in a field, the contour lines are mapped out (See Module 9) and earthen bunds spaced at intervals are created across the slope. Contour bunds can be implemented on a large scale with the bunds constructed using machinery. The space between two bunds may include a catchment strip where water is allowed to gently flow down to the planted area.

It is suitable for the cultivation of different crops, fodder, cereals and trees. As with other forms of micro-catchments water harvesting techniques, when properly constructed where the runoff is high, the system reduces runoff and erosion within the catchment. Where the slope is steep and rainfall intense, the possibility of failure increases. However, this can be managed by diverting flux of incoming water from the field by constructing major drainage channels.

#### Conditions

- Rainfall: 200–750 mm; from semi-arid to arid areas.
- Soils: Agricultural soils
- Slopes: From flat up to 5.0%.
- Topography: Must be even, without gullies or rills.

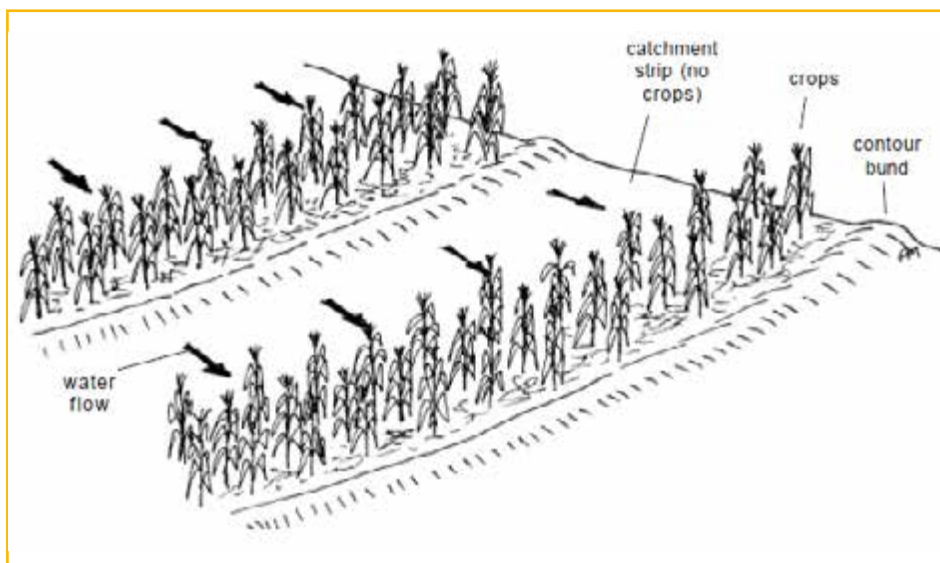

Source: CA manual (2005)

Stone lines: Where stone boulders are available in abundance, the bunds can also be made with stones and built up with earthen materials. This will reinforce the strength of the bund

- Rainfall: 200 mm–750 mm; from arid to semi-arid areas.
- Soils: agricultural soils, pastoral lands
- Slopes: Preferably below 2%.
- Topography: Need not be completely even.
- Stone Availability: Good local supply of stone preferably on site.

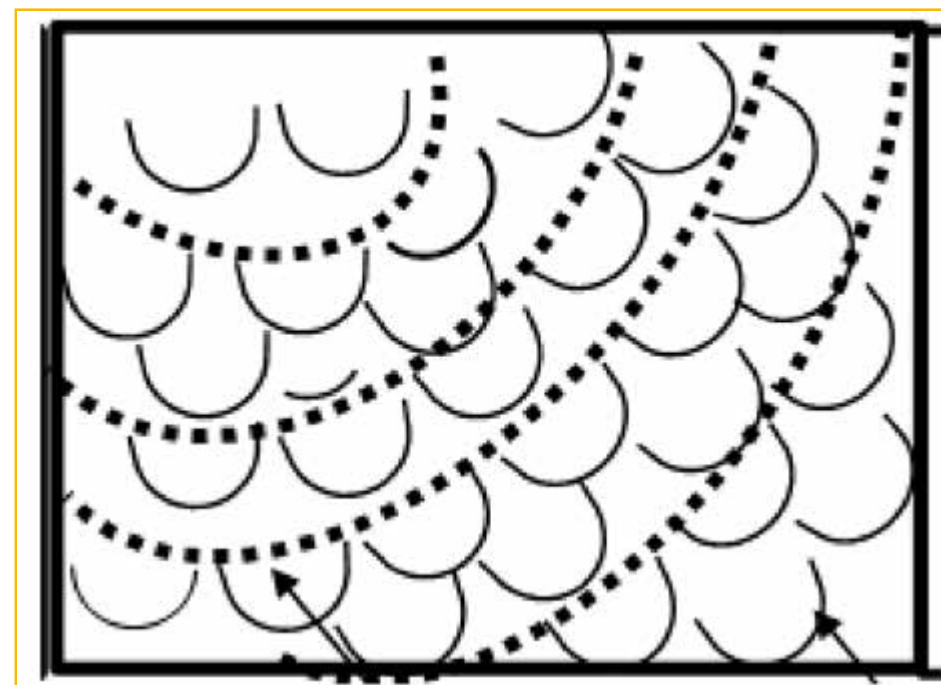

## 2. Half-moon micro-catchments:

These are small, semicircular earth bunds. They are quite common on the desert margins of the Sahel, where they are called “demi-lunes”. The half-moons catch water flowing down a slope. Crops such as sorghum, millet and cowpeas can be planted in the lower portion of the half-moons using conservation agriculture techniques. Half-moons are helpful to rehabilitate degraded land.

### Conditions

- Rainfall: 200–750 mm: from arid to semi-arid areas.
- Soils: All soils which are not too shallow or saline.
- Slopes: Below 2%, but with modified bund designs up to 5%.

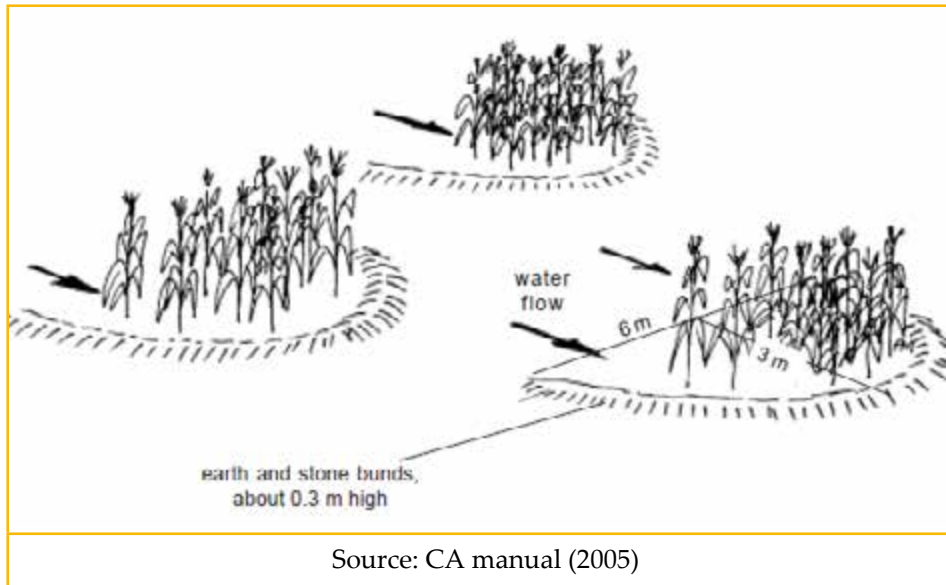

Source: CA manual (2005)

### 3. Planting Pits

Planting pits are very simple hand or mechanically dug circular holes or pits to collect water (runoff) and, thereby, allowing time for increased infiltration. Crops are planted directly in the pit and manures are applied as well to improve soil nutrient for plant development. It is known as *Zai* in Burkina Faso or *Tassa* in Niger. It is a common practice but can make a lot of difference when there is drought at the late stage of crop development.

Each pit is about 20 to 40cm across and 15 - 20 cm deep. Planting pits require a lot of labour, especially when the soil is dry. However, the pits can be used for many seasons after they have been made. They are known to produce good yields in areas where otherwise crops might die because of a lack of water or sudden drought. *Zai* is not recommended on sandy soils and in lowlands. This is because, on sandy soil, the holes are not stable and, in the lowlands, *Zai* risk being permanently flooded.

#### Conditions:

**Rainfall:** 350– 800 mm/year

Slope = < 5%

Dimensions:

- depth 15–20 cm
- diameter 10–40 cm
- spacing 50–100 cm



Source: CA manual (2005)



#### 4. Tied Ridge or Furrow

Ridges are made to create a better bed for plant growth. They are also useful to harness soil nutrient in marginal soils. The furrow created between two ridges can become a waterway for runoff. Tied ridge or furrow in-situ water conservation techniques turn the furrow between the ridges into a temporary water storage pond by blocking the furrow at intervals. Water that is retained in this many 'ponds' within the furrow can infiltrate filling the soil pores. This improves the soil moisture availability for crop development.

##### Conditions:

**Rainfall:** 350– 500 mm/year

Slope = <3%

Dimensions:

- depth: follows the furrow depth (up to 30 cm)
- spacing 50–100 cm

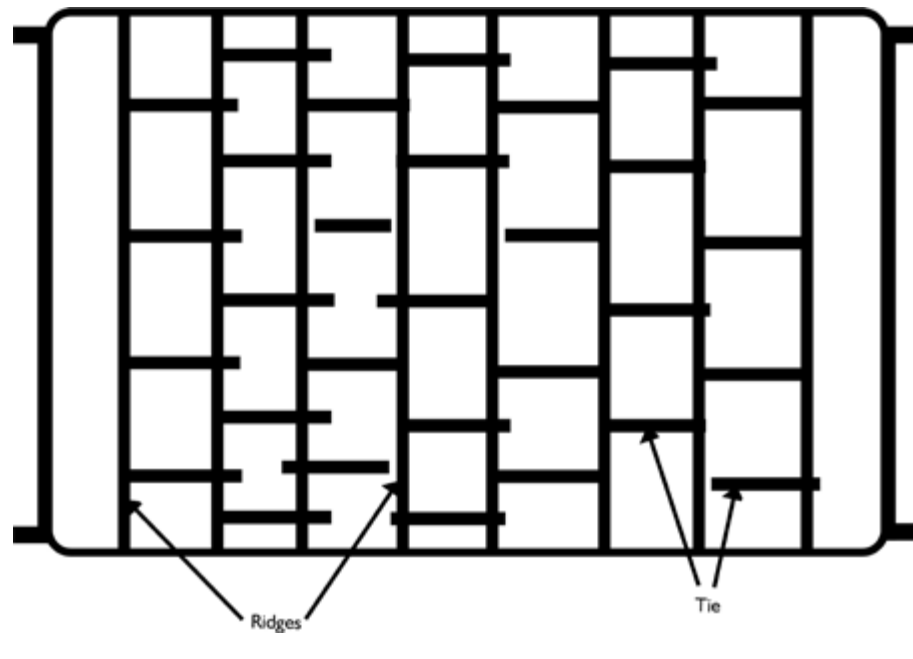

### 13.5 Implementation of In-Situ Water Conservation Techniques

#### i. Contour bunds and contour ridges

- The mapping and construction of contour bunds for contour farming are discussed in Module 9.
- After the construction of the contour bunds, all other farm operations continue following best practices. Tillage, planting, and other agronomic practices for whatever crops to obtain the best yield possible should be adhered to.

#### ii. Micro-catchment: Half-moon

*Layout and construction of semi-circular bunds*

##### Step One

- Stakeout contour by line level (See Module 10)

##### Step Two

- Use a tape measure to mark the tips of the bunds on the contour.
- Mark the centre point between the tips with a peg.
- Fix a piece of string of the length of the radius at the centre peg.
- Swing the end of the strip from one tip to the other.
- Mark the line of the swing with pegs or small stones.

##### Step Three

- Stakeout and construct the bunds in the second and all other.
- Rows are in the same way but staggered rows.

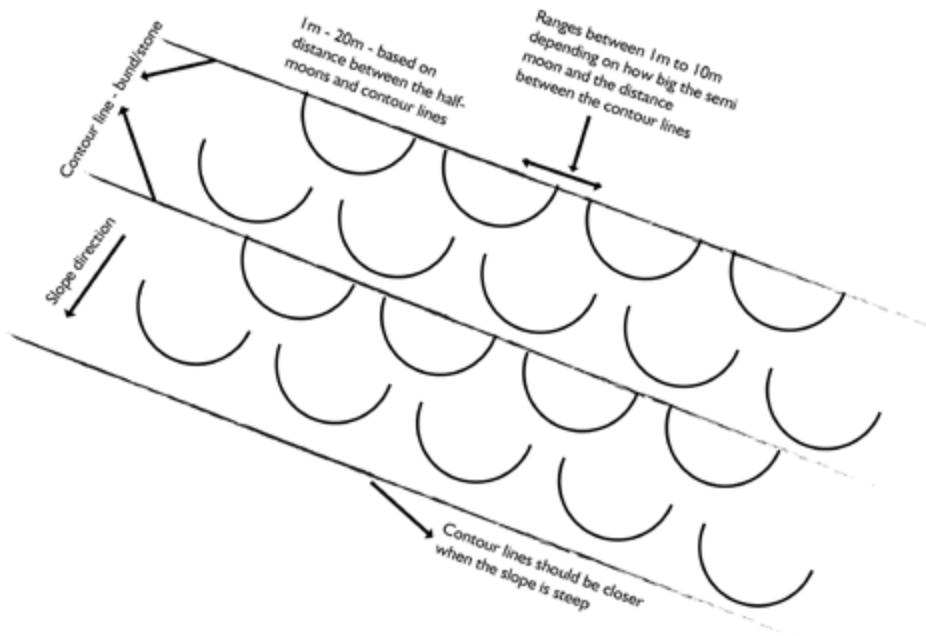

Adapted from Seleshi et al, 2009

**iii. Planting pits**

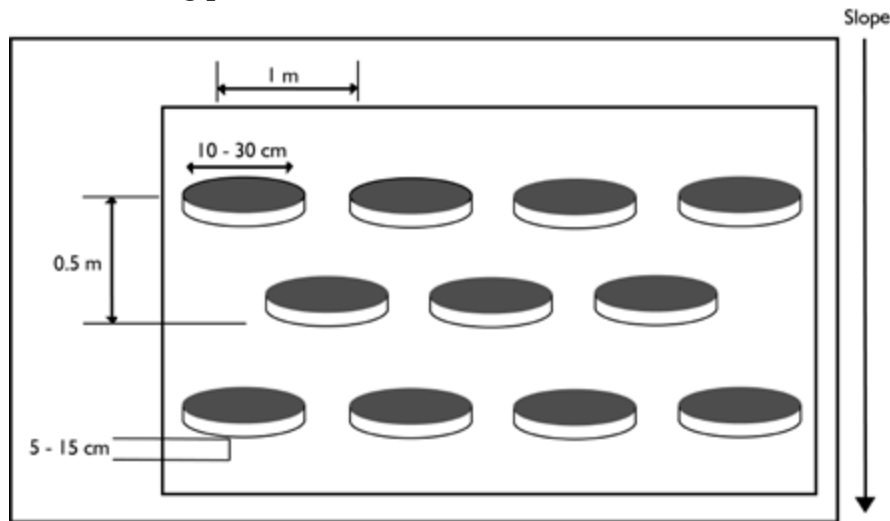

(Source: Seleshi et al, 2009)

**Steps:**

With shovel and hoe,

- Dig each hole/pit with –
- Diameter 10 – 30cm
- Depth - between 5cm to  $\geq 15$ cm (but not exceeding 30cm)
- Spacing 50cm (following crop spacing)

**iv. Tied Ridge/furrow**

**Steps**

- i. After the tillage of your field, make your ridges and furrow as may be required for your crop.

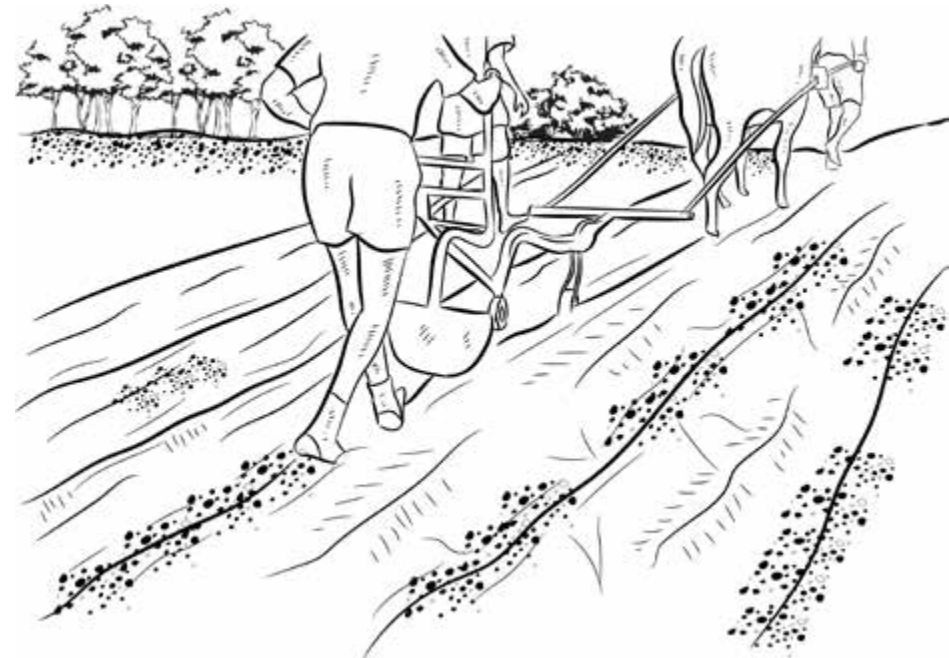

Ridging using animal drawn implement and tractor mounted ridger

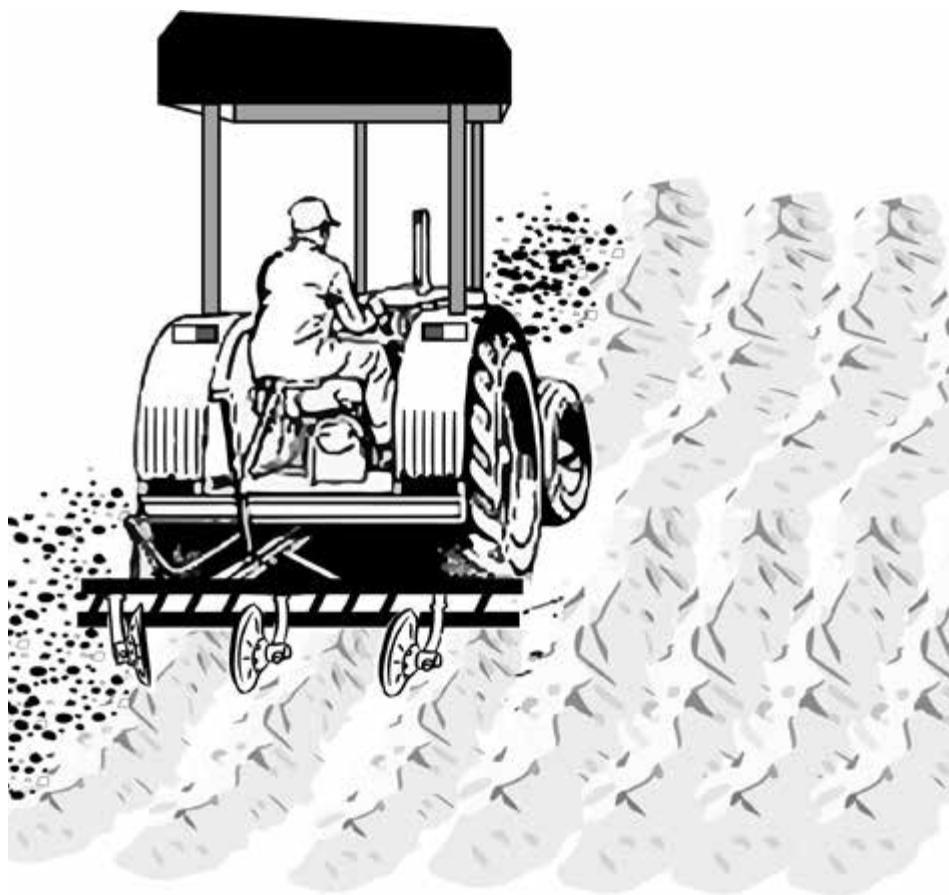

(Source: FAO, 2003)

- ii. With the aid of a hoe/shovel, make bunds (Tie) across each furrow at an interval of 50 – 100cm. This means that several bunds/ties in a furrow. The depression/ponds created between the two bunds serve to retain water and for increase infiltration.

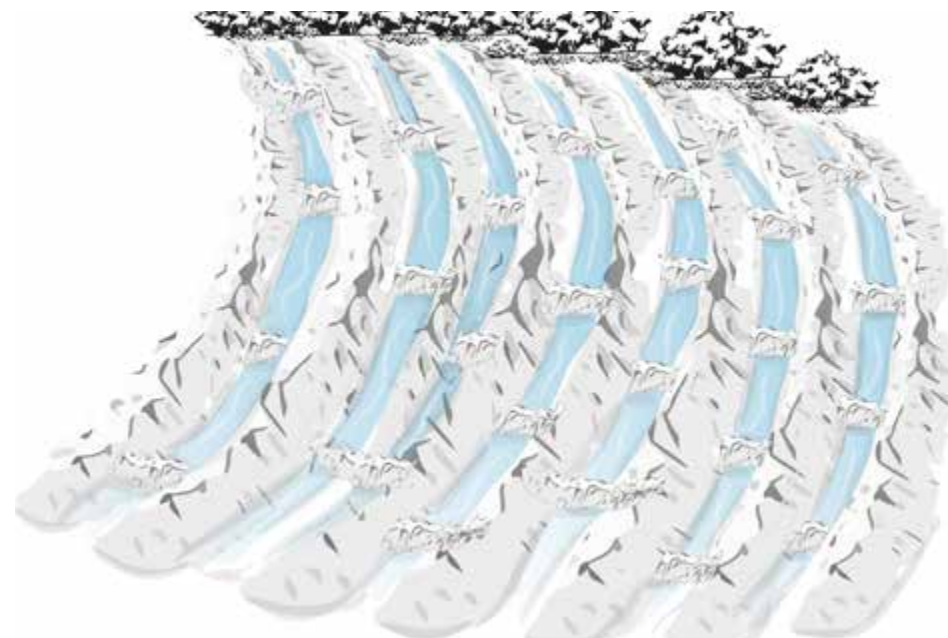

Tied Ridge (Source: Destal, 2005)

- iii. If the soil is heavy (clayey), the interval between the bunds can be farther apart, if the soil is loose and sandy, it should be closer.

### 13.6 Field Maintenance

Some soil water conservation measures are permanent structures while others are installed as part of the land preparation. The permanent structures such as terracing and contour bunds are constantly maintained.

- Avoid indiscriminate tillage.
- Avoid grazing and working over the permanent structures – ridges.
- Ensure that the structure is grassed always and protected from direct rainfall to limit the possibility of erosion.



Other conservation measures such as a tied ridge, planting pits and half-moon are re-constructed as part of land preparation for crop production. Although some of these measures when constructed can be used for more than one season, they often will need some redressing before the next planting time.

### Disclaimer

The mentioning of any equipment brand, illustrated or explained in this module is for the purpose of training. The IWMI does not promote any brand of equipment and will not take responsibility for the choice of any brand.

### Acknowledgement

All the illustrations used in this manual have been appropriately cited. Any omission is hereby highly regretted.

Other photographs used in this manual are courtesy Dr. Aisatta Delphine

### Bibliography

Conservation Agriculture Manual. (2005). Conserving Soil and Water. African Conservation Tillage Network, 20. [www.act-africa.org](http://www.act-africa.org) (Accessed 10 January 2020).

Desta, L. et al. (2005): Part 1: Community Based Participatory Watershed Development: A Guideline. Addis Ababa: Ministry of Agriculture and Rural Development.

Food and Agricultural Organization. (2003). Optimizing Soil Moisture for Plant Production The significance of soil porosity FAO SOILS BULLETIN 79. FAO Rome.

Awulachew, S. B. Lemperiere, P & Tulu, T. (2009). *Training manual on agricultural water management*. IWMI (International Water Management Institute), Addis Ababa, Ethiopia, ILRI (International Livestock Research Institute), Nairobi, Kenya and Adama University, Adama, Ethiopia.







**International Water  
Management Institute (IWMI)**

**Headquarters**

127 Sunil Mawatha, Pelawatte,  
Battaramulla, Sri Lanka

Mailing address:

P. O. Box 2075, Colombo, Sri Lanka

Tel: +94 11 2880000

Fax: +94 11 2786854

Email: [iwmi@cgiar.org](mailto:iwmi@cgiar.org)

[www.iwmi.org](http://www.iwmi.org)

