



AgEcon SEARCH
RESEARCH IN AGRICULTURAL & APPLIED ECONOMICS

The World's Largest Open Access Agricultural & Applied Economics Digital Library

This document is discoverable and free to researchers across the globe due to the work of AgEcon Search.

Help ensure our sustainability.

Give to AgEcon Search

AgEcon Search
<http://ageconsearch.umn.edu>
aesearch@umn.edu

*Papers downloaded from **AgEcon Search** may be used for non-commercial purposes and personal study only. No other use, including posting to another Internet site, is permitted without permission from the copyright owner (not AgEcon Search), or as allowed under the provisions of Fair Use, U.S. Copyright Act, Title 17 U.S.C.*

ANNUAL SHELF

NOT FOR QUOTATION

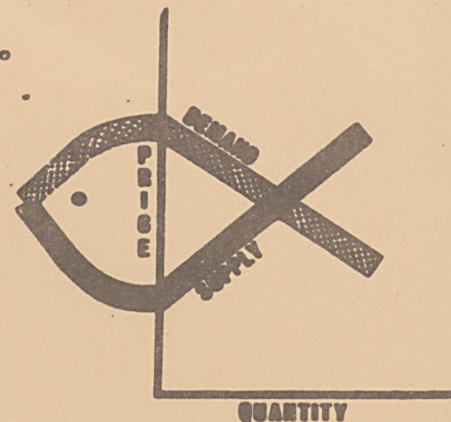

GIANNINI FOUNDATION OF
AGRICULTURAL ECONOMICS
LIBRARY

OCT 8 1975

Study on the Economic Effect of the Investment
for Modernistic Equipment in Japanese Far Sea

Tuna Industries

by

Tosuke Shoji

March 1972

File Manuscript No. 168

U.S. NATIONAL MARINE FISHERIES SERVICE
ECONOMIC RESEARCH DIVISION

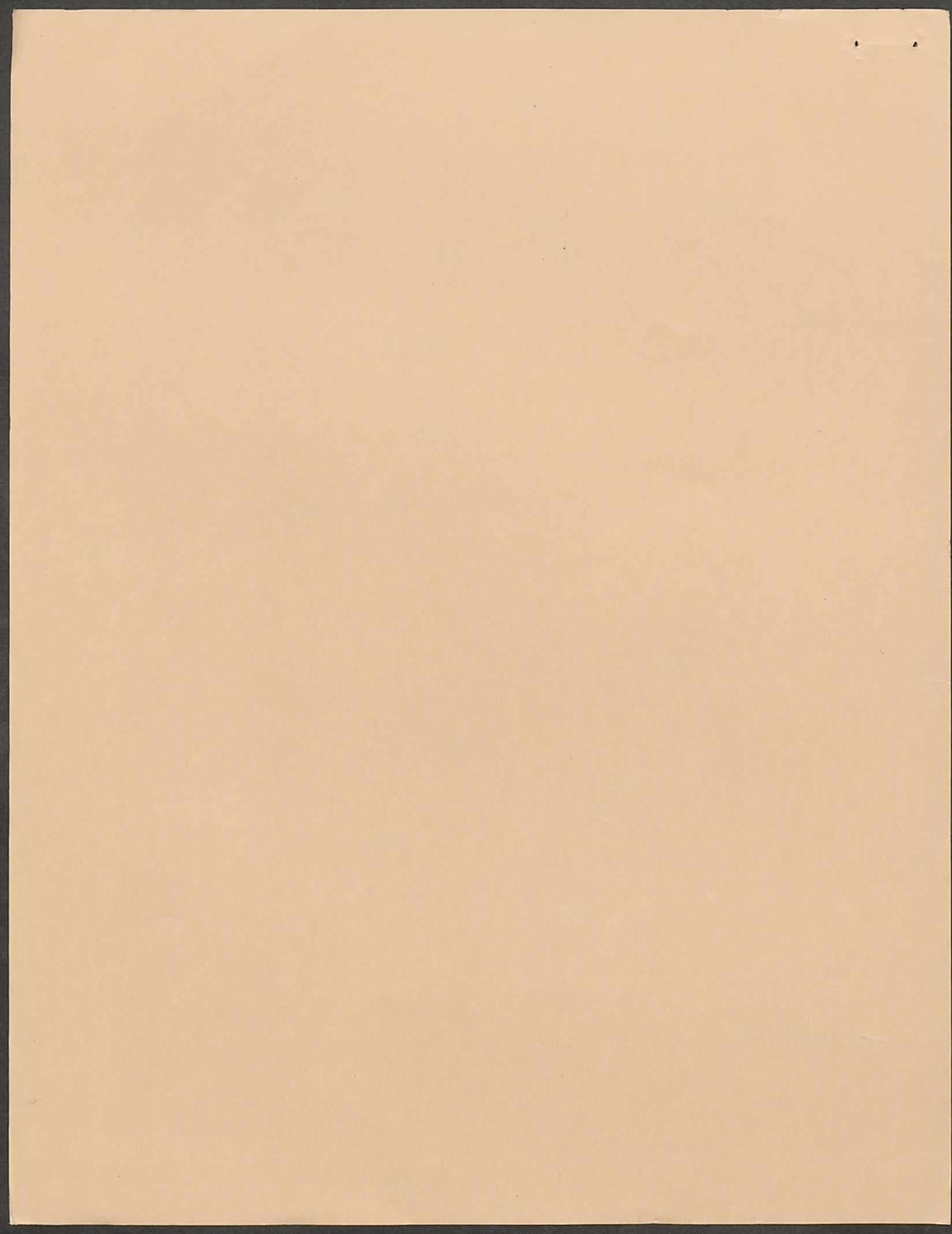

Foreign Fisheries (Translations)
International Activities Staff
National Marine Fisheries Service, NOAA
U. S. Department of Commerce
Page Building, 3300 Whitehaven St., N. W.
Washington, D. C. 20235

STUDY ON THE ECONOMIC EFFECT OF THE INVESTMENT FOR
MODERNISTIC EQUIPMENT IN JAPANESE
FAR SEA TUNA INDUSTRIES

[Paper by Tosuke Shoji; Japan, Tohoku Suiken Kenkyu Hokoku
(Bulletin of Tohoku Regional Fisheries Research Laboratory),
Japanese, No 32, March 1972, pp 95-135]

Table of Contents

1. Prologue to the Modernization of Japanese Fisheries
2. The Post-War tendency toward Specialization in the Tuna Fisheries and the Expansion of the Fishing Grounds
3. Changes in the Export Tuna Market and Changes in the Domestic Market Sales Organization
4. The Modernization of the Tuna Fisheries and the Establishment of a Finance System
5. Management Analysis of the Effects of Modernization Funds on the Specialized Tuna Vessels of Mie Prefecture

1. Prologue to the Modernization
of Japanese Fisheries

It is thought that the starting point in [studying] economic development based on modernization of the material base occurring within society is the concrete manner in which handicraft technology lays the foundation, the feudal mode of production is overthrown, and the self-regulating character of capital

is realized. In Japan, the most classic example is the developmental process of the capitalist mode of production in the bonito-tuna fishing industry and, in conjunction, in the trawling industry.

Under the simple cooperative or manufacturing production systems which formed the starting point of the capitalist mode of production, merchant capital, while itself changing to industrial capital, left the petty producers to their own self-management. Pole and line fishing vessels of the eight-cho scull and mat sailboat era were given power in the mid-Taisho era, and as they gradually extended the area they covered from offshore to deep seas the bonito and tuna fisheries amassed capital as one type of industry, and, from the south-west sea regions to the northeast sea regions, the fishing villages in each area influenced by the Kuroshio warm current system formed so-called medium and small fishing industry capital; one can see the classical pattern in this process. Thus, one must doubtless seek the starting point of modernization in the bonito and tuna fishing industries first in the empowering and enlarging of the fishing vessels and in the tendency toward iron vessels. The empowering of the fishing vessels began with the process of putting about 20 horsepower hot-bulb semidiesel engines in late Meiji, wooden Japanese-style ships enlarged to the 15 ton class. However, the empowering of each area's bonito fishing vessels became

the general practice in the mid-Taisho era after the conclusion of World War I. The state this kind of development in the bonito and tuna fisheries reached differs according to the location of the fishing ports or fishing villages, but at that time, tuna were generally the catch objectives of the large-scale fixed shore net industry and the drift net industry. The bonito pole and line fishing vessels of the empowered wooden Japanese style went from the adjacent seas to offshore, from offshore to the far seas, extending their fishing grounds as the boats gradually became larger.

The bonito fishing vessels thus empowered and enlarged entered the warm current system of the Kuroshio and came to catch seasonally, in addition to bonito, bluefin tuna, yellowfin tuna, and albacore on their way north, either in a mixed catch using the pole and line method or by long line method. Thus bonito fisheries generally came to be called bonito and tuna fisheries. However, the main body of the bonito and tuna fisheries in the late Taisho era remained bonito fisheries to the end. Their boats also were at most 50-ton wooden vessels. Moreover, at this time, during the realization of self-regulation of capital, a violent class division occurred within the class of traditional Japanese style boat owners, and gradually a class of modern medium and small bonito and tuna boat owners was formed in each area. In 1922, first, the Mie Prefecture bonito fishing fleet entered the Kuroshio to pursue the northern going bonito, went north as far as Kamaishi and offshore Miyako in the Tohoku

region, and at that time mostly landed at the ports of Miyako and Kamaishi. The September 1924 Kanto earthquake, however, provided an opportunity for these Mie Prefecture fleets to begin to call at the ports of Ishimaki and Shiogama. Then, bonito fishing vessels from Wakayama and Shizuoka traveled extensively as far north as offshore Mie, and came to accumulate the bonito in each fishing port in the Tohoku region. This gave one sort of stimulus to the development of the bonito fisheries of Fukushima, Miyagi, and Iwate, and the modernization of the bonito fisheries of the Tohoku region gradually became regularized. Thus, the enlarged, empowered bonito fishing vessels of the Tohoku region now, in contrast to this, began to go out to fish as far as offshore Kishu and Satsunan, to go south to these areas immediately after New Year, and also, while returning north, in the Kuroshio to engage in bonito fishing. Lately, Yaizu and Misaki Harbors, which have serviced the enormous fresh fish market of Tokyo, have gradually developed as landing ports for bonito and tuna, but while refrigeration and freezing facilities were poor and the means of transporting the fresh fish were insufficiently developed, this caused the development of the dried bonito manufacturing industries rather than fresh fish transport [in each landing port of the Satsunan region, offshore Tosa, and offshore Sanriku.] However, at this time, the nature of the capital essential to the modernization of the bonito fisheries retained many features from the previous era, and because

the laying in of merchant capital and of capital for ship construction largely depended upon individual loans from relatives, even the enlarging of the bonito fishing vessels was for long unable to escape the limitations of the 50-ton class wooden vessels. Market conditions, too, for some time blocked the road to further development. The fishing industry itself depended, as before, on a system of manual labor which used the fishermen severely. The bonito resources researchers distinguish 5 groups of bonito fishing grounds in the seas adjacent to Japan: (1) the Goto Island area from summer to autumn, (2) the Seinan Island area, (3) the Izu and Bonin Island area, (4) the northeast adjacent waters (30° N and north and 141° E and east) and in some years, (5) offshore of the northeast adjacent waters, (Fisheries Research Collection 8-2, Kawasaki-Ken, "Bonito Ecology and Resources, II," p 53). In addition to these five areas, the fishing grounds near the Hawaiian Islands had begun to be exploited along with the development of capitalist production. At first, mechanical power was introduced into traditional, Japanese style boats (such as eight-cho scull and mat sailboats); then large-size boats (larger than 50 tons) were built as the first step in the modernization of the bonito-tuna fisheries. The next steps toward modernization were a further increase in the size of fishing boats to over 100 tons, from wooden to steel boats, and at the same time the introduction of radio navigation. This began around 1933. In those days, however, bonito-tuna

fisheries had to depend upon subsidies from the national and local governments to pursue modernization in fisheries management. In other words, the first stage of modernization was brought about by private capital and new fishing techniques, but the second stage had to be carried on under protective policies. Then came the period leading up to the Greater East Asia War Era; improved seaworthiness and durability and the introduction of radio navigation onto the 100-ton class boats of all the bonito-tuna fisheries in the northern Pacific was necessary for government policies, i.e., for the military administration. The modernized fishing boats could sometimes function as patrol boats in the northern Pacific Ocean. With the exigencies of the times as a background, the bonito-tuna fishing industries vessels were gradually replaced by steel ships, which were enlarged to the 100-ton class and in the process of this modernization, the trolling industry was developed specializing in the South Seas tuna, with an eye to year-round fishing. For bonito fishing, live anchovy are indispensable. Anchovy caught with stationary nets are kept in sea water for a week and fed, then taken to the fishing ground and kept in a storage pot when the boats go out. When a school of bonito is found, the anchovy are released and a water sprinkler turned on to give an impression of vigorously swimming anchovy. When excited, bonito start to chase the live bait, and pole and line fishing with artificial bait becomes possible. Thus, it is very important to keep the anchovy as lively

as possible and to have a large number of poles, that is, fishermen, in order to get higher angling capacities. However, "pole and line fishing" has critical limitations to its modernization of capital and management. In the first place, anchovy are relatively expensive, and it is not easy to keep them lively on a long trip [to the fishing grounds]. It is lucky enough to keep the anchovy alive, for sometimes not a single anchovy survives a long trip. Secondly, pole and line fishing is a technique that requires fishing efforts concentrated in a short time-period and as many fishermen as possible in the limited capacity of a fishing boat. In those days, a 50-ton wooden boat, for example, would carry 50-60 fishermen. Lastly, the demand for bonito was mainly domestic and prices of canned bonito exported to Southeast Asian countries could not be very high. Consequently, the bonito fishing industry was somewhat unsteady, following schools of bonito over their seasonal drift, and not suitable for rationalization of its management. On the other hand, the tuná fishing industry was more effective; frozen squid or saury pike could be used as bait, in which case a long period of travel [to the fishing grounds] became feasible, as long a period as the boats' refrigerating capacities permit. In contrast to pole and line fishing in the bonito fishing industry, tuna fisheries could use a large number of lines with bait and leave them in a school of tuna for a certain length of time. Even in those

days, when most of the work depended upon physical labor, the crew on a tuna fishing boat was about half the size of that on a bonito fishing boat. The major catch of the tuna fisheries in pre-war days was the yellowfin tuna, and canned yellowfin tuna was exported to America at much better prices than the bonito exported to Southeast Asia. Moreover, it was much easier to assure the modernized canning industry of constant supply by exploiting larger fishing grounds and maintaining a year-round operation. In the process of developing the bonito-tuna industry from the bonito industry, some tuna fishery specialists had already appeared with the modernization of the fishing boats and started exploiting new fishing grounds. That is, from 1938 to 1940-1941, fishing grounds expanded into large areas around the equator: as far as the northern Hawaiian waters in the east; the South China Sea, Sulu Sea, and Celebes Sea in the west; and to 2-3 degrees south latitude. Sailing distance ran up to 5,000 nautical miles over 50 days. (A Look at Bonito, Tuna p 122).

However, until around 1941, the total tuna catch in weight was considerably lower than with the bonito catch as shown in Chart 1. The catch ratio of bonito to tuna in pre-war days was about 7 to 3; it was the post-war era in which the tuna industry became stronger and ultimately surpassed the bonito industry. Discussion of these processes will be found in the next section.

Chart 1. Catch by Japanese Boats
 (Fisheries Research Collection 10-2,
 Kōji Nakamura, "World Tuna Resources II,"
 p 45 Chart 25)

Year	1931	1941	1951	1961
Bonito (ton)	80,346	91,628	104,326	144,327
Tuna (ton)	65,133	46,127	90,332	426,866

Figure 1. The Post-war Process of the Expansion of Fishing Areas
 (Nobuo Okamoto, The History of the Development of the Modern Fishing Industry, p 546)

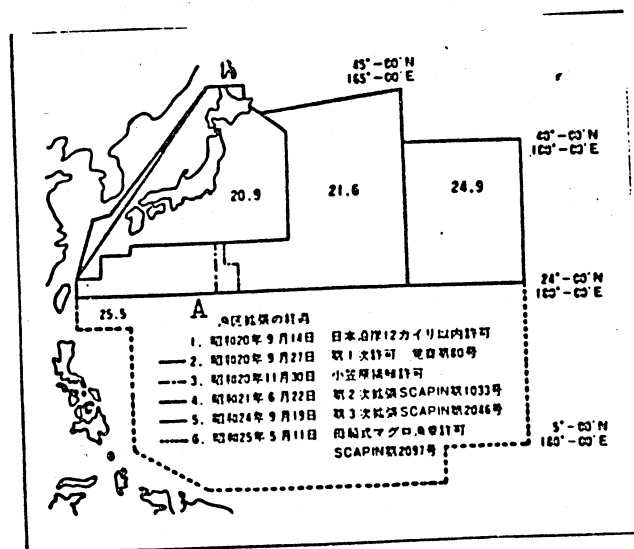

Key:

- Process of the expansion of fishing areas
- 14 September 1945: Permit for within 12 nautical miles off Japan Coast
- 27 September 1945: Permit No 1, Memo No 80
- 30 November 1945: Ogasawara whaling permit
- 22 June 1946: No 2 expansion SCAPIN No 1033
- 19 September 1949: No 3 expansion SCAPIN No 2046
- 11 May 1950: Mothership-type tuna industry permit SCAPIN No 2097

2. The Post-War Tendency toward Specialization
in the Tuna Fisheries and the Expansion
of the Fishing Grounds

There is no doubt that the tuna fisheries were nearly wiped out at the end of World War II. It was quite urgent to reconstruct the fisheries in order to ease the serious dearth of food after the War. The process of expansion of fishing grounds permitted by the Occupation Administration is shown in Figure 1. Mothership-type tuna fishing was permitted in fishing grounds expanded as far as the equator on 11 May, 1950 and fishing ground limitations were abolished by the peace treaty in April 1951. As the bonito and tuna fishing industries, considered typical medium and small capital enterprises since pre-war days, reconstructed themselves, the salmon-trout fisheries, crab fisheries, and trawling fisheries which had lost their fishing grounds as a result of the War and reconverted capital rushed into the bonito-tuna industry. As a consequence, over-fishing was inevitable in the adjacent waters; the bonito-tuna industry

became sluggish as early as 1949. The bonito fisheries around offshore Sanriku were the most hurt by the over-fishing, and the bonito-tuna fisheries started to shift to specialized tuna fisheries. Fishing establishments based at such ports as Misaki and Yaizu got the opportunity to build larger and better mechanized boats for pelagic fishing in the South Seas. The situation was a little different in Mie Prefecture, where the bonito industry was traditionally strong. (This will be discussed in another section.)

"The exploitation for pelagic fishing of the tuna fishing grounds in the Indian Ocean, including the Banda Sea and the Flores Sea, began around 1930-1933. It was begun on the training ship Hakutaka-Marui of the Fisheries Guidance Station, the research vessel Haruna-Marui of the Research Division of the Fisheries Agency, the research vessel Shonan-Marui of the Fisheries Experimental Station of the Government-General of Formosa, and so on. These fisheries investigation vessels covered large areas in the Greater Indian Ocean; namely, the Bay of Bengal, offshore waters of the Andaman and Nicobar Islands, and offshore waters of the West Coast of Australia. They found all of these areas very promising More extensive investigation was resumed around 1953. Exploitation of tuna fishing grounds in the Atlantic Ocean began with the Sagami-Marui of the Fisheries Experimental Station of Kanagawa Prefecture in 1956 and fishing boats began

operations the next year. In 1960, about 80 large-size boats sailed out fishing and caught about 70,000 tons. Since then, our tuna fisheries have established fishing grounds around the equator all over the world." (c.f. A Look at Bonito and Tuna pp 122-3.) A classification of tuna with their characteristics and fishing grounds will be given in the following section. (c.f. Ibid, pp 75-150.).

Tuna Types and their Characteristics

(1) Bluefin Tuna

Bluefin tuna are the largest of the tuna family, reaching up to 3 meters in length and 375 kilogram in weight. The body is cone-shaped and the meat is a little blackish, firm, and relatively rich in fat. The oily meat around the abdomen is the so-called "toro." Winter tuna is particularly delicious; summer tuna is neither as rich in fat nor as tasty because of spawning. Their distribution in the coastal and offshore waters of Japan spreads through the Equatorial Counter-Current and the Northern Equatorial Current to the south, and through the Kuroshio and the northern Pacific Current reaching the Arctic Circle to the north. They are most abundant in the coastal waters along the Kuroshio and its branch currents. Bluefin tuna are most favored in the Kanto and Tohoku areas but not in the Kansai and Kyushu areas.

(2) Albacore

Albacore is a relatively small member of the tuna family; around 1 meter in length and about 30 kilograms in weight at most. The body is long and cone-shaped, with relatively large head and eyes. The Albacore has a long sword-shaped pectoral fin. A Japanese name for Albacore, "binnaga" (long fin), came from this characteristic fin. The meat of the Albacore is pale pink. Since the meat is soft it is not good for sashimi. Oiled meat of Albacore ("sea-chicken") is favored in the United States of America. A large amount of Albacore canned with oil was exported to the United States before the War; however, frozen Albacore exceeded oiled after the War. The distribution of Albacore population spreads from 45 degrees south latitude to 45 degrees north latitude all over the world. The most abundant areas are in the Kuroshio, connected with the northern Pacific Current, and in the California Current. The population density decreases rapidly as these currents run beyond the sub-tropical zone into the Northern Equatorial Current. Albacore stay mostly offshore and seldom reach coastal areas. They migrate in clear, warm currents (temperatures 10-30° C). In Japanese offshore waters, the majority are caught in areas around 20° C. They are caught by pole and line fishing in the summer and drift lines in the winter.

(3) Bigeye

Bigeye grow to be the second largest fish in the tuna family, after the bluefin; they reach around 1.5 meters in length and 20-90 kilograms in weight. They have round, cone-shaped, corpulent bodies. Their meat is relatively soft and pink colored. Therefore, bigeye is inferior to bluefin for sashimi, but still a very popular substitute for bluefin. The meat of bigeye is so-called dark meat, and it is considered low-grade fish meat in the United States and Europe. The distribution of the bigeye population stretches over quite large areas in the Indian Ocean and the Atlantic Ocean, extending east and west all the way with 12-13 degrees width in latitude from south to north, and, in the northern Pacific Ocean, where the distribution is similar to that of Albacore. Consequently, the distribution of bigeye population covers much larger areas from east to west, and the bigeye schools seem to be localized. The most important fishing grounds are in the northern Pacific area and the subtropical zone; the former is an important ground for small and medium size boats from autumn to winter, and the latter is important for medium and large boats from October to spring. Bigeye migrate in the deepest [water] layer of any member of the tuna family, and they change depth noctidurnally. At night, they rise to the surface, and it is possible to fish with drift nets.

(4) Yellowfin

Yellowfin tuna are smaller than bigeye; around 103 meters in length and 25-30 kilograms in weight. The body is cone-shaped, with a small head and a long tail. Usually they stay near the surface. The meat is brilliant pink and good for sashimi and sushi in Japan. This so-called light meat tuna is exported to the United States and Europe as a frozen or canned product. The distribution of the yellowfin tuna population spreads over quite a large area. Yellowfin tuna migrate in the areas of lowest latitude of any member of the tuna family, namely, between 10 degrees south and 5 degrees north, stretching east and west in the Pacific, the Indian, and the Atlantic Oceans. The distribution is considered to be significantly localized and different groups of yellowfin schools migrate in an area which is more or less independent from others. There are some overlappings of these migration areas, but little possibility of affecting the yellowfin tuna population within an area. The distribution in the Pacific Ocean inclines towards the Southern Pacific Ocean, though the center would be around the equator.

(5) Minami Tuna

This was once called Indian tuna or Goshu tuna, but has now been standardized as Minami tuna. Minami tuna has become very popular because the texture of the meat is similar to that of bluefin tuna. The distribution of the Minami tuna population stretches in latitude from 10 to 40

degrees south and in longitude from 110 degrees east to 170 degrees west. There are two types of Minami tuna; one is a large-sized tuna which is caught in coastal areas of latitude 10 to 15 degrees south and longitude 110 to 120 degrees east from September to March, and the other is a smaller type which is found in offshore areas of latitude 20 to 30 degrees south and longitude 100 to 110 degrees east from October to April and of latitude 30 to 40 degrees south and longitude 175 degrees east to 170 degrees west. Recent investigation revealed that the coastal tuna was spawning migrational schools and the offshore tuna was from a mixture of spawning and feeding migrational schools. These three formerly differently named types of tuna, were judged to belong to the same stock, and were differentiated only by their growing ages; then the name was standardized as Minami tuna. The texture of Minami tuna meat is very close to that of bluefin tuna, and it is hard to distinguish the two if Minami tuna is shipped under rapid freezing (below -50°C). This frozen tuna has been sold at nearly the same price as coastal bluefin tuna; therefore, this stock is considered very promising, considering the relative decline in the abundance of the tuna population.

(6) Koshinaga

The Koshinaga is the smallest member of the tuna family. They occasionally attain up to 70 centimeters in length and 7-8 kilograms in weight. The appearance of the

Koshinaga is very similar to that of yellowfin tuna, and it is difficult to distinguish one from the other. The meat is quite pale white compared with that of the yellowfin, and the texture is relatively soft. Summer Koshinaga is particularly delicious and the appearance as sashimi is outstanding.

Koshinaga is a rather rare kind of tuna to the Japanese. In the winter, they are caught with haul seines in southern Kyushu. The distribution of the Koshinaga population reaches southern Kyushu and southern Korea; the fish is much more popular down south. Koshinaga migrate mainly in the coastal areas particularly around islands in the tropical and subtropical zones. The majority of the Taiwanese catch is taken between February and March and in August

Marlin Types and their Characteristics

The Marlin genus is also an important resource for the tuna drift line industry. Every member of the Marlin genus is relatively large. The genus is composed of the striped Marlin family and the Swordfish family; the former is a little flat but the latter is not. Marlin, in general, migrate over large areas, but are not likely to be found in schools as are tuna. The distribution of Marlin spreads widely throughout tropical waters. The Marlin genus tends to migrate in relatively warmer water than does tuna (mostly about 20-28°C).

(1) Striped Marlin

Striped Marlin is relatively small, usually 40-60 kilograms in weight. The meat is white and firm, and favored to the American and European taste as well as being suitable for sashimi. The distribution of the striped Marlin population spreads throughout warm waters, specifically the tropical areas in the Pacific Ocean and the Indian Ocean. In the Pacific Ocean, they migrate as far as 40 degrees north latitude. Some striped Marlin migrate into the Japan Sea but go south around September when the temperature of the water drops. In the South Seas, an area from 15 to 30 degrees south latitude extended east and west becomes a fishing ground from September to January. The major fishing ground in the Indian Ocean is the Bay of Bengal, from March to May.

(2) Black Marlin

The body of the Black Marlin is corpulent and relatively symmetrical when compared with other Marlin. Black Marlin are the largest after the White Marlin, growing up to 3 meters in length and 500 kilograms in weight. There is a great difference in size between male and female. The male grows only up to 100-120 kilograms and the female is the larger one. The color of the meat of the Black Marlin is similar to that of the striped Marlin and the White Marlin. The meat is rich in fat, and the taste is said to be poorer

than that of the Black Marlin; however, this depends upon the season and area. Meat of those caught in April or May is considered delicious. Black Marlin are spread widely throughout warm waters; namely, the northern equatorial zone and also the Indian Ocean. Black Marlin migrate northwards from May to September; at that time, the area 18-28 degrees north latitude becomes a good fishing ground. Fishing season is delayed one month each as the fishing grounds shift eastwards, and the population increases as grounds move eastward, as well as average size, which started around 45-60 kilograms. On the other hand, in the Southern Hemisphere, the catch rate is higher from October to March and lower from April to September in areas 10 or more degrees south latitude. There are no fishing grounds in particular in the Indian Ocean, although it may be possible to catch this type anywhere in the Ocean.

(3) White Marlin

White Marlin grows to be the largest of the tuna and Marlin genuses, up to around 4 meters in length and 570 kilograms in weight. The body is long and markedly flat forward of the anus. The meat is so-called Marlin color, a little paler than that of striped Marlin. The appearance and taste are both good, the oily part being especially delicious and suited for sashimi. The distribution of the White Marlin population spreads over warm waters the year around. They migrate to relatively high latitudes, but the northern limit

in the seas surrounding Japan is unclear. They like the coastal waters around the southern islands, particularly in the Celebes Sea, the Sulu Sea, and the South China Sea. The fishing grounds near Japan are mainly in the East China Sea. They migrate northwards in a narrow zone west of the Kuroshio Current from around April until around September or October then move back south. Their size is 165-210 centimeters from April to June, then around June, small and medium size schools, 140-160 centimeters, begin to appear and move north. In the South Pacific, the most abundant population is found in the northeastern coastal waters of Australia; the best fishing ground is an area in the south latitudes between 10 and 20 degrees, within 250 nautical miles from the coast, and the season is October and November. In the Indian Ocean, major fishing grounds are also in narrow coastal waters around the eastern islands, the Java Sea, the southern coastal waters of Sunda Islands, the Banda Sea, the Flores Sea, and the Arafura Sea. Year-round fishing is rare.

(4) Sailfish

The body of Sailfish is long and slender, with flat sides, and a round tail section. One of the characteristics of Sailfish is a well developed dorsal fin, the longest part is as much as twice the body length. The Japanese name for Sailfish, "basha" marlin, derived from the shape of the dorsal fin which looks like a leaf of "basha", or

plantain. The English name came from "sail." The meat of the Sailfish ranges from pink to red, and the appearance and taste are rather inferior to others, although those caught between April and June are considered the best. The utilization of Sailfish is almost the same as that of other Marlin families, but the Sailfish is a popular object for sport fishing in the United States and Europe. Sailfish are distributed throughout coastal waters among the southern islands, specifically, the East Indian Islands, the coastal islands of Australia, the Philippine Islands, Formosa, and the Ryukyu Islands. In the summer they migrate to the coastal waters of Japan, up as far as the southern coast of Hokkaido. They are seldom found in the mid-Pacific or similar areas of other seas. In the East China Sea, the Sailfish is one of the major fishing objects, along with Striped Marlin, White Marlin, and Swordfish.

(5) Swordfish

Swordfish belongs to the Swordfish family, which is different from the other marlins mentioned above, which all belong to the Striped Marlin family. Swordfish have no scales, and the mature Swordfish does not have teeth or a ventral fin; these are the major apparent differences from the Striped Marlin. The meat is an almost white-pink color and has more fat than the marlins. Cooked Swordfish has a better taste than the raw fish. The majority of the catch is exported to the United States and Europe. In the

United States and Europe, Swordfish is one of the most popular objects of sport fishing; The Swordfish is very wild. The distribution of Swordfish ranges all over the world in the tropical and the temperate zones. In the coastal waters of Japan, the Sanriku coast is one of the best fishing grounds. The fish migrate to the coastal waters of Hokkaido from July to September and move south as water temperatures decrease. During August, a large number of Swordfish migrate to the area east of offshore Hokkaido, between the north latitudes 42 and 46 degrees, longitude 160 degrees east. These schools of Swordfish migrate south to the Sanriku coastal water until November; then in December, the fishing grounds shift to between north latitudes 33 or 34 degrees eastwards to 160 degrees east longitude and westward around 30 degrees to 160 degrees east longitude. From January, southward migration slows down, and stops in March. Then the fishing grounds disappear gradually from the east. Juveniles and alevins of Swordfish are found mainly in the southern areas of the Tropic of Cancer, in contrast to the fishing grounds of adult Swordfish. Maximum population is found in December between the 150 and 160 degrees east longitude, between 160 and 170 degrees in November, and 170 and 180 degrees in October. This indicates that Swordfish migrate westwards. In Japan, Swordfish are caught with harpoons and drift lines.

Figure 2. Major Distributional Areas of the Major Fish
 (Suisan Kenkyu Goshu (Marine Research Collection) 10-1,
 Koji Nakamura, "World Tuna Resources," p 10)

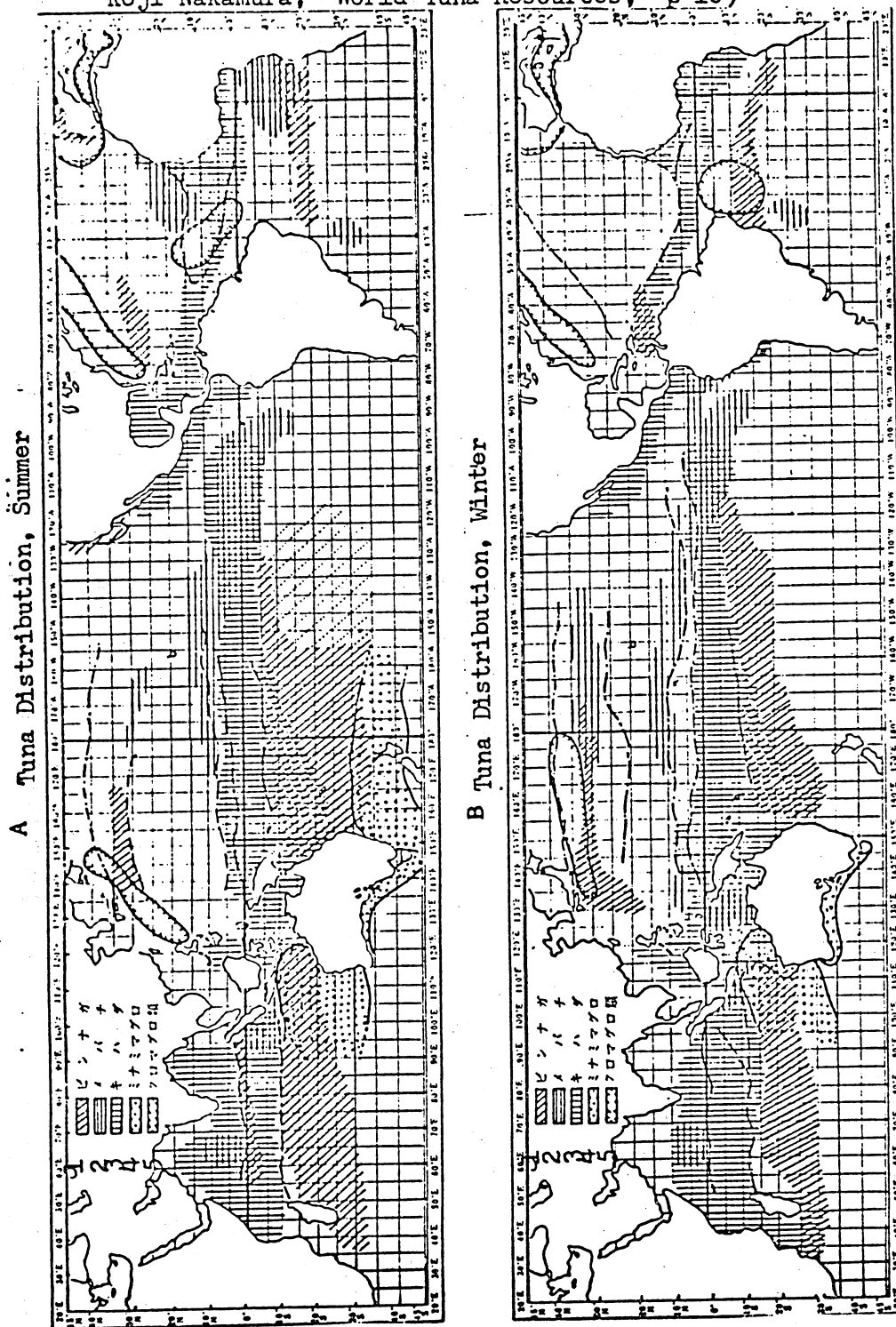

- | | | | |
|------|-------------|----------------|------------|
| Key: | 1. Albacore | 3. Yellowfin | 5. Bluefin |
| | 2. Bigeye | 4. Minami tuna | |

Chart 3. Changes in the Tuna Longline Industry in the last 10 years

Tuna longlining (home based)

	Lines (box)							Trips (x)				Total	
	Total	20 T under	20~50 T	50~100 T	100~200 T	200~500 T	500 T over	Total	20 T under	20~50 T	50 T over		
1957	1,918	413	247	653	365	177	33	1,223	16,409	7,728	2,645	6,036	238,680
1958	1,915	366	318	641	351	201	35	1,231	15,448	6,558	2,696	6,194	258,830
1959	2,182	541	365	687	330	230	29	1,276	21,726	12,306	3,194	6,226	292,061
1960	2,685	843	568	671	298	278	27	1,274	43,698	33,155	4,283	6,260	322,798
1961	2,629	694	685	606	238	377	29	1,250	27,439	16,930	5,252	5,257	351,059
1962	2,503	660	655	553	158	450	27	1,188	28,428	17,727	5,830	4,874	386,176
1963	2,675	774	663	531	199	487	21	1,238	26,019	15,582	6,199	4,238	370,629
1964	2,403	610	701	399	208	477	8	1,092	29,158	20,676	5,025	3,457	320,696
1965	2,392	696	680	352	208	451	5	1,016	28,412	19,753	5,611	3,018	310,578
1966	1,877	147	697	324	214	488	7	1,033	11,180	3,041	4,976	3,163	346,470
1967	1,909	147	704	301	226	524	7	1,058	11,395	3,499	4,926	2,970	340,871

Note: Boats under 10 T not included after 1966.

Key:

- Over 50 T subtotal

Tuna longlining (Atlantic operations)

Year	Lines (box)	Trips (x)	Catch (ton)	Price (100 million yen)	Catch by Fish (ton)							
					Tu-Alba-nacore	Big eye	Yellow fin	Striped marlin	Black marlin	Sail fish	Other	
1957	26	60	15,885	14.1	63	860	454	13,198		1,176		134
1958	51	131	30,984	28.9	34	1,992	453	27,159	161	135	772	119
1959	62	189	50,831	51.4	256	3,614	1,478	44,071	112	99	841	28
1960	88	243	72,946	69.3	684	8,516	2,801	57,756	106	345	1,517	191
1961	88	258	82,251	85.6	1,385	11,819	11,030	52,631	620	629	2,700	157
1962	95	306	60,369	83.2	2,624	15,336	10,035	26,857	672	38	2,396	35
1963	100	303	59,407	73.8	4,300	16,411	7,294	20,137	1,126	470	3,661	257
1964	144	329	69,475	77.5	6,468	22,715	9,380	20,491	1,762	1,165	4,199	522
1965	169	462	86,030	98.4	5,357	29,625	16,482	20,416	2,728	1,682	3,267	1,580
1966	121	271	49,292	71.8	1,801	18,727	9,514	10,264	1,687	1,059	1,859	787
1967	49	137	23,251	33.1	525	11,342	3,826	4,729	477	377	522	311

Loading Mothership Tuna Longlining

Year	Mothership		No. of Trips loading boats	Catch (ton)	Price 100 million yen	Tuna
	No	Total tonnage				
1961	4	5,555	8	4,675	6.4	0
1962	22	26,003	16	40,241	58.5	1,237
1963	38	39,293	88	61,555	97.1	3,077
1964	45	52,027	114	67,708	95.9	6,186
1965	50	55,116	126	66,963	87.2	4,322
1966	49	49,956	113	54,294	77.3	1,073
1967	44	46,784	105	41,910	58.3	545

(Agriculture and Forestry totals, fiscal 1967, pp 44-45)

Catch (ton)			生産額 (億円)	Catch by Fish Type (ton)									
20T under	30~ 50T	50 T over		2 まぐろ	3 びんが	4 めばち	5 きわだ	6 まか じき	7 めか じき	8 くろ かわ	9 ばし うかじ	10 その他	
1,683	15,907	221,073	208.1	13,864	18,443	48,833	75,915	5,760	10,057	27,990	1,637	36,281	432
2,143	17,011	239,638	252.9	12,807	24,022	65,738	69,477	8,428	12,773	27,013	1,887	36,685	33
1,884	22,086	268,087	338.2	36,331	32,649	68,801	67,247	8,710	13,136	24,348	2,474	38,365	31
3,433	31,622	284,738	342.6	53,518	35,484	65,448	81,185	7,388	13,896	22,055	2,158	41,666	35
1,954	48,673	300,428	379.6	58,183	31,815	97,223	76,252	7,413	14,566	22,881	1,926	40,800	36
1,957	60,128	324,087	467.1	32,590	47,087	103,990	90,755	13,561	17,594	28,172	3,418	49,009	37
1,452	51,648	314,524	490.4	45,254	38,169	105,317	73,646	13,947	16,628	26,059	3,473	43,136	38
2,382	52,724	265,585	455.1	37,361	29,240	83,999	61,626	21,395	14,988	20,955	3,372	47,760	39
3,283	55,098	252,197	492.0	34,690	25,321	73,030	64,848	18,837	14,834	19,175	10,811	49,032	40
2,128	76,814	267,528	626.9	31,864	36,649	78,625	81,851	17,852	17,039	18,953	8,217	55,370	41
2,707	72,243	265,920	676.2	45,321	36,135	86,459	59,170	18,666	16,039	16,587	9,465	58,023	42

Chart 2. Tuna longlining (foreign based)

Lines (box)	Trips (x)	Catch (ton)	生産額 (億円)	Catch by Fish Type (ton)										
				2 まぐろ	3 びんが	4 めばち	5 きわだ	6 まか じき	7 めか じき	8 くろ かわ	9 ばし うかじ	10 その他		
58	260	8,816	7.2	—	5,625	500	1,551	—	1,101	—	—	—	39	432
86	374	15,849	14.5	—	10,760	567	2,986	—	1,402	—	—	—	134	33
78	386	16,630	18.8	22	12,029	726	2,542	96	43	1,037	29	106	34	
86	385	16,414	9.6	8	11,899	863	2,594	436	79	452	8	75	35	
87	399	17,297	12.9	89	11,305	1,211	3,423	190	52	897	51	79	36	
135	492	25,064	23.9	—	15,588	2,130	5,407	288	116	1,037	25	473	37	
199	647	28,017	23.0	322	15,853	3,025	5,522	600	223	1,468	51	953	38	
193	613	34,895	34.3	350	16,924	4,770	8,442	615	571	1,595	179	1,449	39	
167	552	31,508	30.6	194	15,005	4,049	7,855	996	437	1,567	193	1,212	40	
126	504	32,256	40.9	83	17,032	3,793	7,751	724	450	1,193	136	1,094	41	
112	412	23,309	32.1	193	14,329	2,543	3,404	547	396	852	98	947	42	

Alba- core	Catch by Fish Type (ton)						Other	
	Big eye	Yellow fin	Striped marlin	Sword fish	Black marlin	Sail fish		
1,779	428	1,951	60	73	179	28	177	436
7,108	7,010	17,812	1,133	454	3,183	596	1,708	37
13,476	10,485	23,379	1,629	844	4,985	817	2,863	38
18,686	10,935	19,733	2,314	1,080	4,406	826	3,542	39
14,358	14,757	21,345	2,567	1,311	3,361	1,116	3,826	40
10,433	12,578	18,936	2,527	1,183	2,615	1,331	3,618	41
5,173	9,982	16,752	2,157	766	2,142	903	3,490	42

Key:

- 1. Price (100 million yen)
- 2. Tuna
- 3. Albacore
- 4. Bigeye
- 5. Yellowfin
- 6. Striped marlin
- 7. Swordfish
- 8. Black marlin
- 9. Sailfish
- 10. Other

An introduction to the fish genres and families and fishing grounds for the tuna fishery are given above. There are types of tuna and marlin and their fishing grounds spread out into every water influenced by the warm currents. Specialization of the tuna fisheries and exploitation of new fishing grounds started after Japanese Independence in 1951, and grew rapidly from 1952 to 1957. This specialization and exploitation is due to the building of large-sized fishing boats, modernization of accommodations, and improvement of fishing gear and techniques. Table 3 shows the statistics over 10 years for changes in the drift line tuna fisheries. Fishing boats smaller than 20 tons show little change until 1965, with their peak 843 in 1960, but show a drastic change in 1966, decreasing by 147. The class of boats between 20 and 50 tons, which became an objective for designated bonito-tuna fisheries in December 1963, increased from 685 in 1961 to 704 in 1967. In 1957, the lower limit for medium size bonito-tuna fisheries increased to 20-40 tons, and free operations became possible. One then saw a rapid increase in so-called 39-ton boats. However, after a revision in December 1963, the limit changed to 20 tons and the boats became smaller again. The 50-100 ton class [of medium size bonito-tuna fisheries] which could not go to larger sizes, was united with the offshore bonito-tuna fisheries in February 1963, then shifted to the larger size, 100-200 ton

class. Statistics, however, do not show this change, apparently because the former 100-200 ton class shifted to the 200-500 ton class after 1961. The numbers of vessels in the 200-500 ton class increased from 177 in 1957 to 524 in 1967, which is a 2.9 times increase in 10 years. On the other hand, vessels in the 500-ton and greater class decreased from its peak, 35 vessels in 1958, to 8 in 1964, and only 7 in 1967. Therefore, the third step of modernization of the tuna fisheries is particularly significant for the change in the 200-500 ton class. In the modernization of the post-war fisheries industry in Japan, modernization of the arts of navigation is very important, along with the building of larger sized boats and increasing cruising speed. The Goniometer, radar, LORAN (long-range navigation), auto-steerer, fish finder, fathometer, remote controller, and cooling machine are among typical instrumental improvements, in addition to advanced fishing gear and techniques and the application of oil pressure mechanics, which really helped to minimize the physical work required. These modernizations in tuna fisheries industry are particularly significant with respect to the 200-500 ton class tuna fishing vessels. The increase in the distance of the voyages to the fishing grounds, in their duration, and in the number of fishing lines, and the strengthening and economizing of labor power have encouraged mechanization of

drift line operations. A line hauler was invented to minimize the severe physical work and was installed around 1931 or 1932. However, in those days, main lines were still arranged manually unit by unit. Only recently was the arrangement of main lines mechanized using a reel and winder, and the setting and unsetting of the branch lines were also mechanized, with semi-mechanization of line heaving. A typical drift line is shown in Figure 3. One unit of main lines is 360 meters in length, using three three-folded twist 55 multi-fil Cremora. Around 1957 Cremora took the place of the traditional cotton. For a single operation, four or five branch lines of around 20 meters in length are attached to each main line with 300-400 units; the total length is around 100-120 kilometers and the number of fishhooks is about 1,500-2,100. The mechanization of the hauling operation was a key point for rationalization of the labor force, and now it came to be realized by two different systems: the auto-reel system and the line winder system. At first, the former was used, a method which entails winding the main lines with an auto-reel placed at the stern. About 100 tuna fishing boats use this system. (cf. Suisan Sekai (Marine World Vol 17 No 8 p 53)). An auto-reel is a machine which is to be placed at the stern; it is considered too large and results in too great a weight increase, more hazardous operations, and larger horse power requirements. Then, recently, the line

Figure 3. Structure of a Tuna Long-line Unit

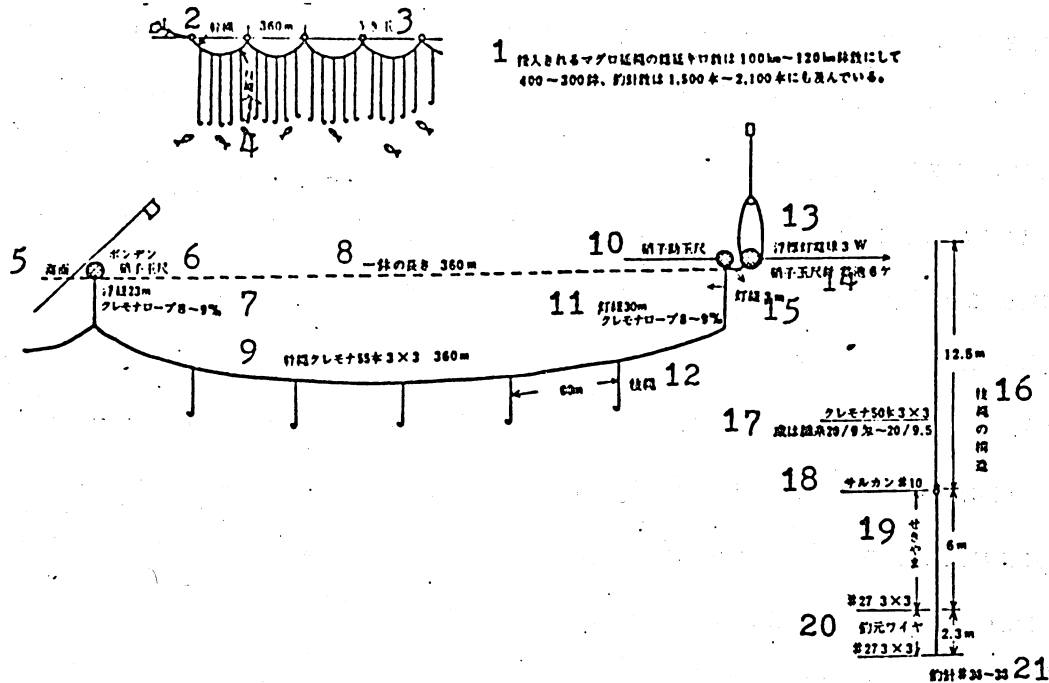

Key:

- | | |
|---|--|
| 1. The total length of the tuna long-line to be thrown in is 100-120 kilometers; there are 400-300 units; the number of lines reaches 1,500-2,100 | 12. Branch line |
| 2. Main line | 13. Light buoy electricity 3w |
| 3. Float | 14. Glass float, electric battery 6k |
| 4. Branch lines | 15. Light line 3m |
| 5. Surface | 16. Branch line structure |
| 6. Buoy, glass | 17. 50 strands Cremora, or cottonline 20/9.5 |
| 7. Buoy line, Cremore rope 8-9 m/m | 18. Swivel #10 |
| 8. One unit length 360 m | 19. Seizing ladder |
| 9. Main line, 55 strands Cremore rope 809 m/m | 20. Hook wire |
| 10. Auxiliary buoy, glass | 21. Fishhook #36-38 |
| 11. Light line 30m, Cremora rope 809 m/m | |

winder system, which is operated semi-automatically with an application of an oil pressure installation was introduced. Figure 4 shows a schematic diagram of the line winder, which directs main lines would by a winding drum and supporting rollers using bend pipes. Recently, the auto-reel system (Fig 5) was also improved so that there is no particular superiority of one system over the other. In any case, this mechanization of the drift line operation reduces the work load of 15 or 16 fishermen to that of 5-6.

Another example of modernization in fishing is the disposition of the catch. In pelagic tuna fishing, high-powered rapid cooling machines with a capacity of -45° - -50° C were first introduced around 1953 and were generally renewed around 1965. Japan no longer enjoys domination of the tuna exporting market after recent strong entries of Korea and Taiwan. Consequently, Japanese pelagic tuna fishing has largely to depend on domestic demand, which is supported by the "sushi boom," for high economic growth. For exporting tuna, albacore, or yellowfin, the cooling capacity required is only -20° - -30° C, but for the domestic demand for sushi and sashimi a much higher cooling capacity is required to compete with fresh tuna from coastal and offshore fishing grounds. This problem is particularly important with respect to the recent popularity of Minami tuna, which is similar to bluefin tuna. When the fishing grounds

Figure 4. Linewinder Method
 (Suisan Sekai (Marine World) Vol 8 No 17, August 1968,
 No 52, p 55)

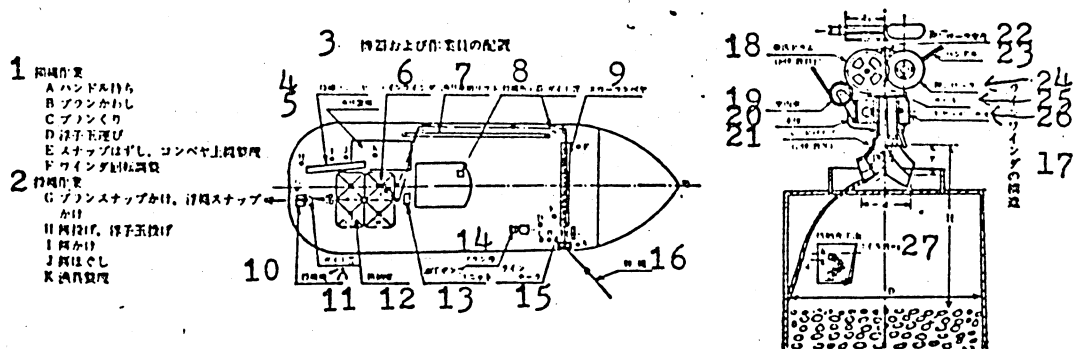

Key:

- | | |
|------------------------|-----------------------------|
| A. Handle holder | G. Branch snapper, float- |
| B. Branch line changer | line snapper |
| C. Branch line winder | H. Bait, float thrower |
| D. Float mover | I. Bait hanger |
| E. Snap remover, con- | J. Bait releaser |
| veyer mechanism | K. Equipment control |
| F. Winder revolution | |
| control | |
| 1. Stationed rope | 14. Branch |
| operation | 15. Line hauler |
| 2. Thrown rope opera- | 16. Main line |
| tion | 17. Construction of Line |
| 3. Placement of Mach- | Winder |
| inery and Operators | 18. Winding drum |
| 4. Rope conveyor | 19. |
| 5. Equipment control | 20. |
| 6. Linewinder | 21. |
| 7. | 22. Push roller branch |
| 8. | 23. Handle |
| 9. Slow conveyor | 24. Push roller |
| 10. | 25. |
| 11. Guide | 26. Car box |
| 12. | 27. Container, no. of coils |
| 13. Oil pressure pump | |
| unit | |

Figure 5. Auto Reel
(Ibid., p 80)

Equipment and Location

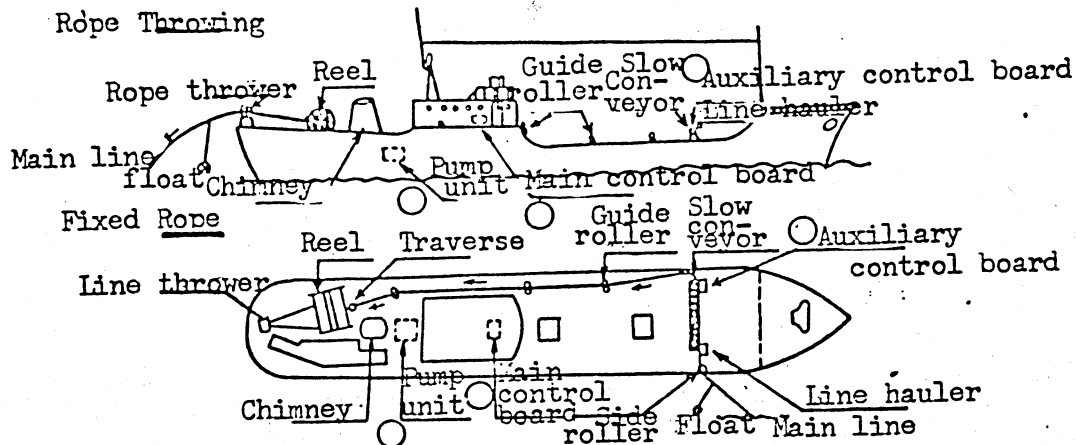

Reel Weight: approx. 2,300 kg No. of winds: 450 (1 = 360 m)

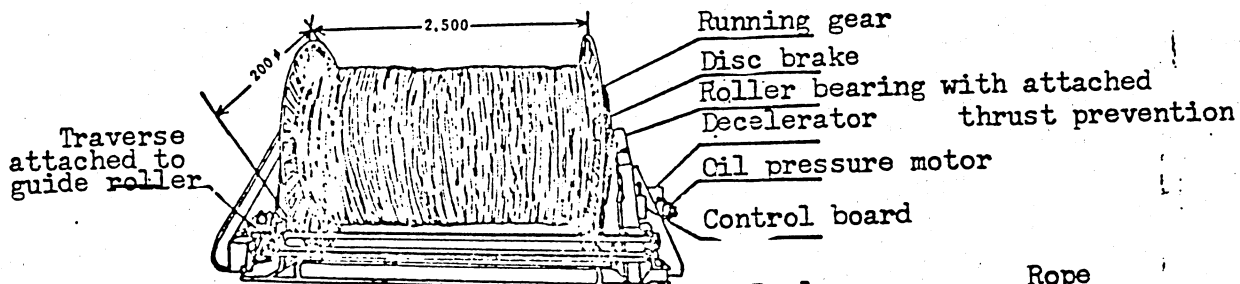

	Acceleration time	Arresting time (approx.)	Reel revs.	Torque	Rope speed
Thrown rope	Time of largest amount, approx. 60 seconds	3 seconds	48-480 R/M	20 kg/m	5m-10m/sec
Fixed rope	Approx. 20 seconds	2 seconds	19-190 R/M	50 kg/m	2m-4m/sec

Weight: approx. 500 kg
Tire contact pressure spring (Regulating style)

Reel

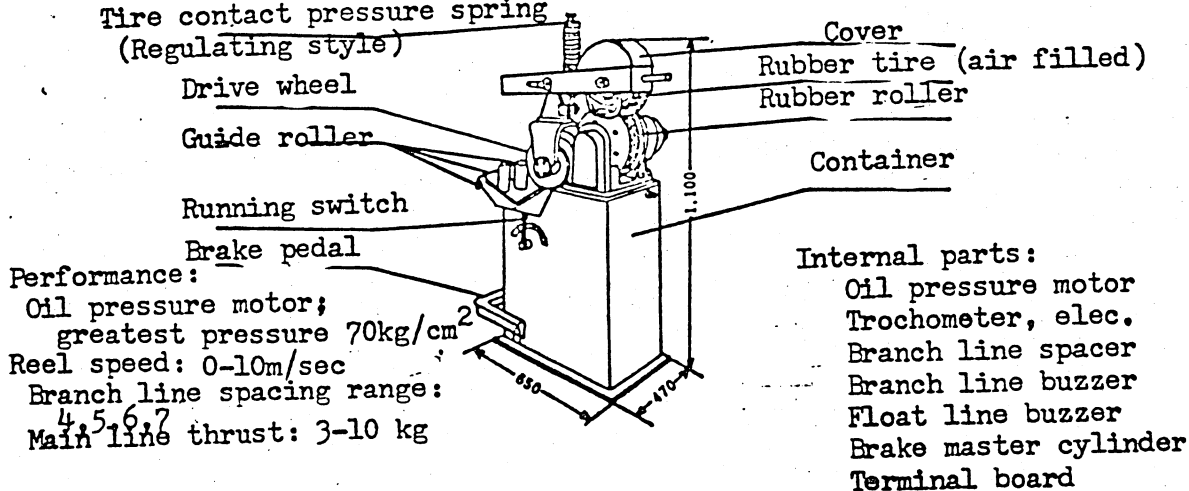

Performance:
Oil pressure motor;
greatest pressure 70kg/cm²
Reel speed: 0-10m/sec
Branch line spacing range:
4, 5, 6, 7
Main line thrust: 3-10 kg

are in the Indian Ocean and offshore waters of Australia in the high latitudes of the Southern Hemisphere (over 40 degrees south as shown in Figure 6), fishing boats have to have high powered rapid cooling machines with a -45° - -50°C capacity. The installation of these cooling machines was more urgent than the nationalization of labor power or building larger fishing boats because of its direct influence on tuna prices. Therefore, the tuna industry was so sensitive to this point that even old fishing boats were willing to install high-powered cooling machines. Unlike the past, when frozen tuna was considered too poor in quality for sushi and sashimi, tuna frozen under -45°C with this new cooling machine can compete with bluefin tuna, or even yellowfin tuna and bigeye.

3. Changes in the Export Tuna Market and Changes in the Domestic Market Sales Organization

Although pelagic tuna fishing was looking up, Japan's tuna fisheries came to a turning point around 1962-1963. The total catch by the pelagic drift line industry had a maximum of 478,000 tons in 1963, then decreased to 354,000 tons in 1967; decreases in over-seas based fisheries, the Pacific Ocean operations, and mothership-type fisheries are particularly significant. (See Chart 4). One of the reasons for this change might be that improved productivity in the drift line tuna industry induced international competition and changed the international market for exporting

Figure 6. Activity of the Tuna Boats of Yaizu

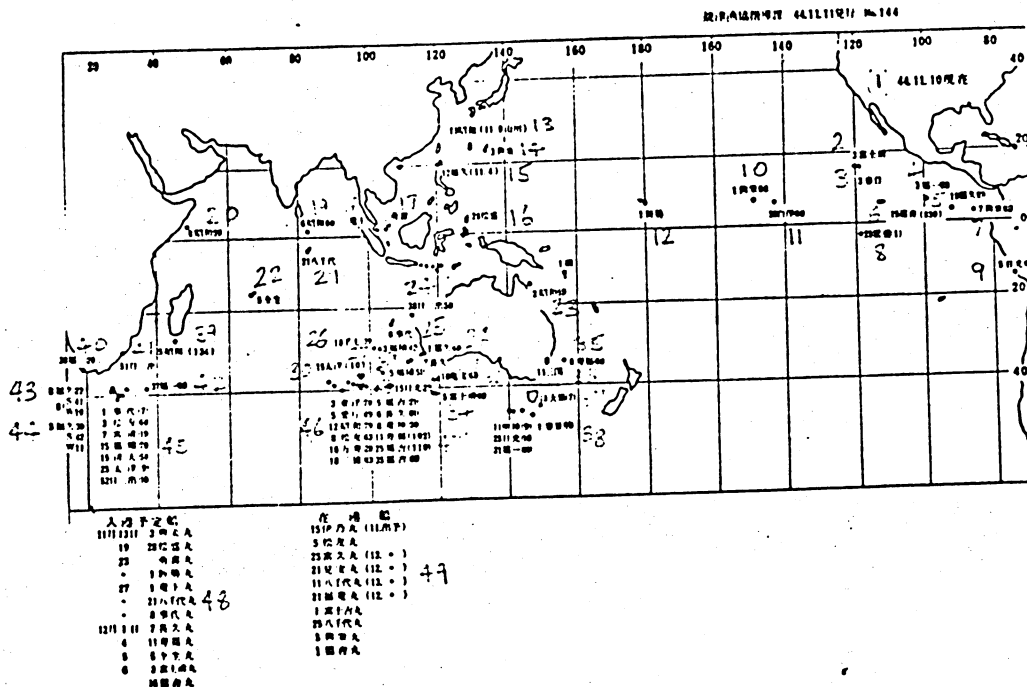

Key:

- | | |
|--------------------------------|-----------------------|
| 1. As of 10 Nov. 1969 | 23. 2 Showa (55) |
| 2. 3 Fujikiyo | 24. 38 Himide (50) |
| 3. 3 Kasuga | 25. 8 Jidai |
| 4. 3 Fukuichi | 26. 18 Heishichi (39) |
| 5. 15 Fukuhisa | 27. 3 Fukuzumi (42) |
| 6. 15 Fukuyoshi (859) | 28. 1 Fukuhisa (44) |
| 7. 7 Koei (62) | 29. 7 Nagahisa |
| 8. 25 Shosei (1) | 30. 15 Taiyo (103) |
| 9. 5 Nikko | 31. 5 Fukuzumi (51) |
| 10. 1 Koei (64) | 32. 18 Kameho (65) |
| 11. 28 Hakuyo | 33. 15 Nikko (22) |
| 12. 1 Shinsei | 34. 5 Fujikiyo (65) |
| 13. 11 Showa (9 Nov. Yamakawa) | 35. 8 Jufuku (34) |
| 14. 3 Koei | 36. 11 Mikuni |
| 15. 12 Fukuhisa (4 Nov.) | 37. 13 Daikoku (7) |
| 16. 28 Shosei | 38. 1 Kasuga (11) |
| 17. Yuki | 39. 5 Showa (134) |
| 18. Ryuo | 40. 38 Fukuichi (26) |
| 19. 6 Showa (84) | 41. 51 Himide |
| 20. 8 Showa (39) | 42. 37 Fukuichi (60) |
| 21. 21 Yachiyo | 43. 8 Fukuhisa (22) |
| 22. 5 Kinsei | 44. 5 Fukuhisa (36) |

Key (cont.):

45. 1 Jidai (7)	46. 3 Toyo (70)	47. 5 Fukuyoshi (21)
3 Matsuyu (64)	5 Aicho (85)	6 Chokyu (91)
7 Tonikiyo (19)	12 Showa (79)	8 Ryujin (34)
15 Fukuzuri (70)	8 Shoyu (62)	11 Jufuku (102)
15 Kiyofuto (54)	18 Manju (28)	25 Fukuyoshi (110)
25 Taiyo (9)	18 Mitoku (43)	35 Fukuyoshi (33)
52 Himide (16)		

48. Entry of Scheduled Ships

Nov. 13	3 Koei Maru
19	28 Shosei Maru
23	Yuki Maru
23	1 Shinsei Maru
27	1 Ryuo Maru
27	21 Yachiyo Maru
27	8 Jidai Maru
Dec. 1	7 Chokyu Maru
4	11 Jufuku Maru
5	5 Kinsei Maru
6	3 Fujikiyo Maru
6	15 Fukuyoshi Maru

49. Ships Remaining in Port

15 Ino Maru (scheduled depart. 11)
5 Matsuyu Maru
25 Fukuhisa Maru (sched. dep. 13)
21 Mitakara Maru (sched. dep. 12)
11 Yochiyo Maru (sched. dep. 13)
21 Fukuryu Maru (sched. dep. 12)
1 Fujiyoshi Maru
25 Yachiyo Maru
5 Koei Maru
1 Fukuyoshi Maru

Chart 4-1. Changes in the Tuna Longline Industry over the last 10 years (2)

Self-navigating mothership tuna longline

	Mothership		Daughterships		No. of trips	Catch (ton)	Price D-ship		Tuna
	No.	Total tonnage	No.	Tonnage			100 million-yen		
1957	3	18,244	96	11,590	...	14,105	11.4	5	
1958	3	14,331	88	10,681	...	14,384	13.1	4	
1959	4	27,102	162	18,191	...	20,688	29.9	6,595	
1960	5	30,745	215	23,894	215	24,002	24.7	594	
1961	5	31,096	209	24,132	209	28,932	39.2	369	
1962	4	25,264	208	22,201	208	24,514	32.7	189	
1963	2	13,858	112	12,488	112	13,998	16.8	93	
1964	3	21,517	103	13,749	103	14,509	16.6	889	
1965	1	5,043	37	4,637	37	4,708	5.8	12	
1966	-	-	-	-	-	-	-	-	
1967	-	-	-	-	-	-	-	-	

Summary of Tuna Longline Industry

	Catch by Type of Fish (ton)									
	Total	Tuna	Alba core	Big eye	Yel-low fin	Stri-ped Marlin	Sword fish	Black Marlin	Sail fish	Other
1957	277,486	13,932	28,053	51,641	95,817	6,153	10,168	30,746	1,783	38,017
1958	320,047	12,845	40,870	68,668	104,278	9,395	13,107	28,778	2,214	38,490
1959	380,210	43,204	53,846	72,369	116,780	9,672	13,559	27,038	2,724	41,018
1960	436,160	54,804	63,870	70,821	150,122	8,690	14,567	25,559	2,670	45,057
1961	484,214	60,026	68,857	111,888	141,289	9,825	15,708	28,737	2,666	45,218
1962	536,364	36,640	95,719	125,197	145,904	17,289	18,590	36,083	4,598	56,344
1963	533,606	53,046	88,879	127,826	126,067	17,987	18,373	37,167	4,911	59,350
1964	507,283	51,254	92,303	110,852	114,043	26,514	18,289	32,074	4,946	57,008
1965	499,787	44,575	85,729	109,001	116,108	25,237	18,363	27,589	13,765	59,420
1966	482,312	34,821	82,841	104,510	118,802	22,790	19,781	24,620	10,471	63,676
1967	429,341	46,584	66,979	102,810	84,055	21,847	17,578	20,103	10,777	58,608

- Note: 1) Marlin types were not differentiated in foreign based and Atlantic operations for 1957, and are dealt with comprehensively, but are separated by fish type in detail for Motherships and home based operations.
- 2) The principle of the Fishery-differentiated totals and the comprehensive totals of these totals by fishing ground differ.
- 3) In Atlantic operations after 1966, operations were carried on on the return to Japan and the figures include the catch brailed in Japan.
- 4) After 1966, catches from ships under 10 T not included (included in the "other" totals).

(Fiscal 1967 Agriculture and Forestry totals, pp 44-45)

Catch by Type of Fish (ton)								
Alba- core	Big- eye	Yellow fin	Strip- ed Marlin	Sword fish	Black Marlin	Sail fish	Other	
3,125	1,854	5,153	393	111	1,655	246	1,563	32
4,096	1,910	4,656	806	199	993	208	1,512	33
5,551	1,364	2,920	754	281	812	193	2,215	34
7,971	1,709	8,587	760	247	1,535	313	2,286	35
12,139	1,996	7,032	1,542	388	2,080	504	2,882	36
10,600	2,032	5,073	1,635	388	1,295	524	2,778	37
4,970	1,705	3,383	685	208	994	313	1,647	38
4,738	1,768	3,751	428	485	919	47	1,484	39
1,420	683	1,644	109	99	219	65	457	40
—	—	—	—	—	—	—	—	41
—	—	—	—	—	—	—	—	42

2) Catch by Region of Operation											6
Pelagic Tuna Longline (ton)										近海	Offshore
Total	Pacific				Indian Ocean		Atlantic Ocean		20~50 T 本土基地		20T under (ton)
	Total	本土基地 (50T 以上)	外国基地	独航型 母船式	とう載型 母船式	Total	大西洋 操業	とう載型 母船式	基地 (トン)		
259,891	244,009	221,088	8,816	14,105	—	15,885	15,885	—	15,908	1,684	32
300,855	269,871	239,638	15,849	14,384	—	30,984	30,984	—	17,044	2,143	33
356,236	305,405	263,087	16,630	20,688	—	50,831	50,831	—	22,086	1,884	34
398,100	325,151	281,738	16,414	24,002	—	72,946	72,946	—	34,622	3,433	35
433,583	351,332	300,428	17,297	28,932	4,675	82,251	82,251	—	48,673	1,954	36
474,275	376,841	305,307	25,064	24,514	21,956	97,434	79,149	18,285	60,128	1,957	37
477,501	372,918	311,201	28,017	13,998	19,732	104,553	62,730	41,823	54,648	1,452	38
452,172	328,107	265,585	34,895	14,509	13,118	124,065	69,475	54,590	52,724	2,382	39
441,406	300,526	252,197	31,508	4,708	12,118	140,880	86,030	54,850	55,098	3,283	40
403,370	315,769	267,528	32,256	—	15,985	87,601	49,292	38,309	76,814	2,128	41
354,390	312,882	265,920	23,309	—	23,653	41,508	23,251	18,257	72,243	2,707	42

Key:

1. Home based (over 50 T)
2. Foreign based operations
3. Self-navigating motherships
4. Loading boat motherships
5. Atlantic operations
6. Coastal: 20-50 T home based

Chart 4-2. Yearly Totals Differentiated by Pelagic, Offshore,
and Coastal Fisheries
Pelagic Fisheries

(1) No. of fishing lines

Tuna longline	1957	1958	1959	1960	1961
1 独航型母船式	(3) 96	(3) 88	(4) 162	(5) 215	(5) 209
2 とう載型 "	—	—	—	—	4(8)
3 大西洋操業	26	51	62	88	88
4 外国基地 "	58	86	78	86	87
5 本土基地 "	1,228	1,231	1,276	1,274	1,250
6 計	1,408	1,456	1,516	1,663	1,642

(2) Product -- Amount

1 独航型母船式	14,105	14,384	20,688	24,002	28,932
2 とう載型 "	—	—	—	—	4,675
3 大西洋操業	15,885	30,984	50,831	72,946	82,251
4 外国基地 "	8,816	15,849	16,630	16,414	17,297
5 本土基地 "	221,073	239,638	268,087	284,738	300,428
6 計	259,879	400,855	356,236	398,100	433,583

(3) Product -- Price

1 独航型母船型	11. ⁴	13. ¹	29. ⁹	24. ⁷	39. ²
2 とう載型 "	—	—	—	—	6. ⁴
3 大西洋操業	14. ¹	28. ⁹	51. ⁴	69. ³	85. ⁹
4 外国基地 "	7. ²	14. ⁵	18. ³	9. ⁶	12. ⁹
5 本土基地 "	192. ⁸	234. ²	310. ⁶	297. ¹	320. ⁹
6 計	225. ⁵	290. ⁷	410. ⁶	400. ⁷	465

(1967; Gyogyo Yoshoku Seisan Tokei Ho (Report on total production in fishery breeding), Ministry of Agriculture and Forestry, p 360)

Key: 1. Self-navigating mothership 4. Foreign based operations
2. Loading boat " 5. Home based operations
3. Atlantic Ocean operations 6. Total

Unit: box

	1962	1963	1964	1965	1966	1967	
(4) 208	(2) 112	(3) 103	(1) 37	—	—		
22(66)	38(88)	45(114)	50(126)	49(113)	44(105)		
95	100	144	169	121	49		
135	199	193	167	126	112		
1,188	1,238	1,092	1,016	1,033	1,058		
1,692	1,737	1,646	1,346	1,393	1,324	16,823	

Unit: ton

24,514	13,998	14,509	4,708	—	—		
40,241	61,555	67,708	66,963	54,294	41,910		
60,369	59,407	69,475	86,130	49,292	23,251		
25,064	28,017	34,895	31,508	32,256	23,309		
324,087	314,524	265,587	252,197	267,528	265,920		
474,275	477,501	452,174	441,406	403,370	354,390	4,451,769	

Unit: 100 million yen

32. ⁷	16. ⁸	16. ⁶	5. ⁸	—	—		
58. ⁸	97. ¹	95. ⁹	87. ²	77. ³	58. ³		
83. ²	73. ⁸	77. ⁵	98. ⁴	71. ⁸	33. ¹		
23. ⁹	23. ⁹	34. ³	30. ⁶	40. ⁹	32. ¹		
387. ³	405. ¹	371. ²	396. ⁰	489. ⁷	553. ³		
585. ⁶	615. ⁸	595. ⁸	618	679. ⁷	676. ⁸	5,563. ²	

tuna, which the Japanese pelagic tuna fishing industry used to dominate. Post-war tuna fisheries had taken the place of canned salmon-trout-crab producers as the leading exporters of canned or frozen products with yellowfin tuna and albacore. They accelerated the specialization of tuna fisheries by exploiting new international markets in Europe like Italy, besides the United States. Then a drastic change came over the promising international markets for frozen tuna. As shown in Chart 6, the total amount of exported frozen tuna in 1966 was recorded as 186,000 tons, the maximum, then decreased 73,000 tons to 113,200 tons in 1967. For the international markets for frozen tuna, the total amounts were 115,000 tons to the United States and 60,000 tons to Europe in 1965, decreasing to 73,400 tons to the United States and 30,000 tons to Europe in 1967.

In 1968, the amount of exported frozen tuna reached 114,831 tons, which was a 1.4% increase over 113,239 tons in 1967, but price-wise it brought 49,330,000 dollars, a 1.6% decrease from 50,087,000 dollars. This indicated that the price per ton decreased. On the other hand, the amount of imported frozen tuna from newly-rising countries such as Okinawa, Taiwan, and Korea increased significantly from 16,190 tons (5,790,000 dollars) in 1967 to 28,963 tons (a 78.9% increase) and 10,680,000 dollars (an 84.4% increase) in 1968. It is not hard to understand that the growth of the

Chart 5. Trends in Permitted Ship Force in the Bonito-Tuna Industry

Year	Specialized Industry Permits					Total ves.	Tonnage ton
	(40) ton- 100 ton vessels	100~200 vessels	200~500 vessels	500~1,000 vessels	1,000~ vessels		
1947						956	72,864
1948						1,146	94,230
1949	913	249	1			1,163	96,426
1950	849	250	1			1,100	92,158
1951						1,187	101,471
1952	840	268	20	2		1,130	102,826
1953	830	270	50	4		1,154	112,945
1954	835	330	89	7	2	1,263	142,893
1955	805	422	131	11	3	1,372	176,026
1956	758	436	159	22	5	1,380	197,191
1957	622	415	172	25	9	1,243	200,228
1958	622	393	193	25	10	1,243	205,420
1959	566	353	229	28	11	1,187	210,932
1960	508	297	284	28	12	1,129	218,278
1961	409	204	386	22	9	1,030	220,188
1962	474	139	464	18		1,095	224,572
1963	580	142	467	12		1,201	231,350
1964	286	303	553	7		1,149	247,991

Notes:

1. According to data from Fisheries Agency Sea Fishery Bureau No 2.
2. Specialized industry permitted 20-100 ton class became 40-100 tons after 1957.
3. The temporary permit was a permit regarding mackerel boats and so forth along with the establishment of the Rhee line; actually, permission was for all year around.
4. The one changed from the 1960 North Pacific salmon-trout was within the 9 month period of the permit, and was ratified by the 1960 all year around permit.
5. Generalized fishing industries permit operating period within 6 months.

Chart 6-1. Export Rates for Tuna by Fiscal Year
(Compiled from the yearly report for 1967 on marine product flow totals, pp 10-11)

Units: Amount M/T; Canned products, 1,000 cans; Price, 1,000 dollars

Fiscal Year	Item	Frozen Tuna-Marlin		Canned Tuna	
		Amount	Price	Amount	Price
1963		154,889	51,773	4,199	35,206
1964		184,502	62,003	4,572	37,599
1965		174,756	59,094	4,476	35,719
1966		186,061	88,383	5,280	47,559
1967		113,239	50,087	5,688	51,510
1968		114,831	49,330	—	—

(From Sekai Suisan Soran, Agriculture and Forestry Economic Research Laboratory, p 487)

Special Permits		3 35年北洋サケ マスから転換 漁業許可		4 とうり載型母船式カ ツオ・マダロ漁業		5 近海カツオ・マダロ漁業	
Temp. Permit vessel	1 vessel	3 vessel	Mothership No Tonnage vessel ton		Loading Boats vessel	No	Tonnage
		156					
79		329					
74		339					
65		306					
27		220					
27		224					
30		221					
2 専業許可に繰入	49	217					
		50	6	7,500	12		
2 専業許可に繰入		220	26	32,973	78		
		208	38	39,293	90		
		166	50	55,055	124	1,708	64,390

- Key:
1. Change from 1960 North Pacific salmon-trout
 2. Change to specialized industry permit
 3. Generalized industry permit
 4. Loading boat mothership bonito-tuna industry
 5. Coastal bonito-tuna industry

Chart 6-2. Export Rates by Major Area for Fiscal 1967
(Compiled from the yearly report for 1967 on marine product flow totals, pp 10-11)

Item Country	Frozen Tuna-Marlin		Item Country	Canned Tuna	
	Amount (ton)	Price (1000 dollars)		Amount (ton)	Price (1000 dollars)
America	33,183	17,929	America	25,806	26,884
Italy	29,528	12,766	W. Germany	10,666	8,183
Puerto Rico	27,583	11,227	Canada	3,158	3,152
Fiji	3,633	1,150	England	2,298	2,041
Amer. Samoa	10,081	3,835	Belgium	1,953	1,631
Malaya ll Is.	1,726	754	holland	1,564	1,325
Other	3,757	1,297	Switzerland	1,577	1,490
			Other	2,747	2,456
Total	109,498	48,958	Total	49,769	47,162

Chart 6-3. Statistics on Amounts of Bonito-Tuna Imports

Note: The unit is the kiloton and the 1,000 yen;
 NHR stands for New Hebrides (Suisan Sekai
 (Marine World) April 1968 issue, Vol. 17 No 4
 p 24)

		A 昭 41 年	B 42 年	
C 総 輸 入 量		10,796	16,184	2,085,455
D 主 要 国 別 輸 入 量	琉 球 E 球	5,169	6,407	996,214
	韓 国 F 国	1,343	3,739	411,230
	中 共 G 共	215	45	4,562
	台 湾 H 湾	1,931	2,061	260,369
	マ ー I ー	212	586	69,934
	比 利 時 J 島	331	495	49,178
	米 国 K 国	35	410	50,836
	N H R	914	1,345	131,465
	サ ー L ー	621	401	43,938
	パ ー M ー	162	162	17,874

Key:

- A. 1966
- B. 1967
- C. Total amounts of imports
- D. Amounts of imports according to the major importing countries
- E. Ryukyuan Islands
- F. South Korea
- G. People's Republic of China
- H. Taiwan
- I. Malaya
- J. Philippines
- K. United States
- L. Samoa
- M. Panama

tuna industry was rapidly expanded in these newly-rising countries and the United States, and that they had become strong competitors of Japan. As we review tuna fishing in the United States, "Tuna fisheries still used inefficient, old-style pole and line methods or surrounding nets until around 1952" and with the higher costs of production, they could hardly compete with Japanese frozen tuna. However, "around 1958 they succeeded in developing a power block to wind nylon purse seine very rapidly, this caught a large number of schools of yellowfin tuna migrating northward in the coastal waters from South America to California every year between January and June, Off-season was from July to December ... American purse seiners sailed out in this slack season to the Gulf of Guinea in 1968 eight seiners caught more than 10,000 tons the number of tuna fishing boats operating at present has reached 120 ..." And the problem of the tuna market in the United States changed "from restriction of imports to limitation of catch" (Suisan Shuho (Marine Weekly Report) No 559 October 1969 Special Edition p 42-43). Korea operated fisheries experimental vessels in the Indian Ocean in 1957. In June 1963, they established the Korean Fisheries Development Corporation and obtained fishing boats and gear by loan agreements between Korea and France and Italy; Japanese capital from Japan-Korea claims of property agreement was applied to exploiting

pelagic fishing. The Korean government was particularly interested in the development of pelagic tuna fishing in their measures for the promotion of fishery. During 1963-1965, they possessed only 23 boats and 4,005 tons; but this increased to 111 boats and 22,106 tons by May 1966, and 186 boats and 45,702 tons by 1969. This represented an 8.1 times increase in the number of boats and an 11.4 times increase in tonnage within less than 10 years. "Now, Korean fishing fleets navigate literally over the Seven Seas Korean tuna fishing bases in July 1969 number as follows: American Samoa (70 boats), Fiji Islands (18 boats), New Hebrides (7 boats), Free Town, Sierra Leone (21 boats), San Martin, West Indies (4 boats), Abidjan, Ivory Coast (3 boats), Las Palmas (10 boats), Durban, South Africa (20 boats), Tamatave, Madagascar (9 boats), Penang, Malaysia (6 boats), and Fortaleza, Brazil (3 boats)" (Suisan Shuho (Marine Weekly Report) No 580 October 25). With respect to management, "eight private tuna fisheries other than the Korean Fisheries Development Corporation own from 1 to 16 fishing boats (average 6.7 boats) in corporations formed with foreign capital." (Kaigai Suisan Goshu (Foreign Fisheries Collection) 12-2, "Korean Fishing Industry II (3)" p 73). The post-war situation of fishery development in Taiwan was "By strong grant-in-aid programs by the government fishery reconstruction proceeded rapidly, and the number of

fishing boats reached 330 in 1949" ... Then with aid from the United States or corporations formed with Japanese fisheries, the number of fishing boats increased to 749 in 1964.

In those days, 90% of all boats were small size boats of less than 50 tons. This is because Taiwan has a particular advantage as far as location is concerned. The fishing boats from the bases in Kao-hsiung Shih or Pingtung Hsien sailed out in the coastal waters of the Ryukyu Islands, the nearest adjacent seas; all the areas of the South China Sea; the Sulu Sea; the Celebes Sea; the Banda Sea; the Flores Sea; etc." (Kaigai Suisan Gosho Koji Nakamura, "Taiwan's Tuna Industry" p 11).

Chart 7 shows that "large size boats borrowed from the International Bank for Reconstruction and Development are not included, ... The fourth 4-year construction plan begun in 1965 indicates the construction of 16 tuna drift line fishing boats of the 250-ton class on a loan from the World Bank ... Domestic construction of fishing boats and applications to foreign countries for large size boats are continuing ... the numbers of boats are still increasing because there are no limits on size and number as of now." (ibid., p 10) Besides the countries mentioned above, communist nations such as the USSR, the People's Republic of China, and Cuba, as well as Okinawa, have

become strong in tuna fishing. The development of tuna fisheries in these nations, particularly in Korea and Taiwan where labor costs are still low, resulted in a great change in the international tuna market; in other words, a large amount of frozen tuna were exported to the United States and Europe, thus decreasing the Japanese share of exported frozen tuna significantly.

The amount of frozen tuna exported from Korea and Taiwan is shown in Chart 8; in 1968 they increased their exports to more than double to the United States and 3 times to Europe (compared to 1967 exports), and also a 1.8 times increase to Japan. When we include the exports directly from foreign fishing bases, about 30,000 tons, the total comes to 125,000 tons, already surpassing Japan. Japanese tuna fisheries have tried to shift their attention to the domestic demand for sushi-dane and sashimi, rather than concentrating on exporting. Thus, eventually, most of the fisheries withdrew from the fishing grounds in the Atlantic Ocean and operated in the Southern Hemisphere from domestic bases, rationalized labor by using the auto-reel or line winder, and improved the ability to maintain freshness by rapid freezing. Along with the rapid freezing machines of -45° to -50° C capacity, an air blast hanger system was developed which further improved the tuna industry. The air blast hanger is a system in which, by hanging the fish upside

Chart 7. Changes in the Scale of the Taiwanese Tuna Long-line Industry

Year	No of boats	Tonnage	Horsepower
1953	353	6,762.17	10,987
1954	417	8,847.34	13,185
1955	423	9,640.42	14,529
1956	412	9,911.73	15,881
1957	448	12,443.00	19,713
1958	503	14,438.98	25,832
1959	472	13,779.45	24,959
1960	629	15,163.47	28,195
1961	663	15,056.03	27,893
1962	725	16,958.88	32,310
1963	678	19,133.49	37,608
1964	749	20,184.77	41,005

Number of vessels according to class

Ship class (ton)	No of boats	Total tonnage	Total horsepower
5 ~ 10	302	2,124.66	7,410
10 ~ 20	194	2,124.66	7,410
20 ~ 50	198	6,012.18	9,571
50 ~ 100	18	1,323.91	2,270
100 ~ 200	26	3,759.18	8,450
200 ~ 350	5	1,318.66	2,500
350 ~ 500	4	1,472.88	3,000
Over 500	2	1,226.06	2,100

(Kaigai Suisan Goshō, Kōji Nakamura, "Taiwan's Tuna Industry," p 9)

Chart 8. Amounts of Frozen Tuna Exported by Korea and Taiwan

	To U.S. ton	To Europe ton	Japan ton
1967	22,000	4,000	16,000
1968	53,000	12,000	29,000

(The portion dealing with inter-trade of Japanese trading companies only, taken from Suisan Shuko No 559, p 42)

down and locking the tail, the fish is automatically carried into a freezer of -45°C capacity through a jet of super-cooled air (below -50°C). This air blast hanger system, however, has disadvantages as well as advantages; some fishing boats are still using this system in conjunction with cooling racks. For example, the auto-reel or line winder could reduce labor requiring 29 men to requiring 25 men, and the auto-reel with an air blast hanger could reduce that number by two more. A double-deck pioneer type developed recently would reduce the number further, to 18 men; this number is now considered the minimum requirement. Pioneer type tuna fishing boats such as the First Seiju-Maru (297.27 tons), the Second Seiju-Maru (298.35 tons), and the Seventh Seisho-Maru (298.44 tons) or sail-all-the-seas type boats such as the Seventeenth Cho Sho-Maru (404 tons), which make it possible to sail in all weather, indicate the direction of modernization in large size tuna fishing boats in Japan as they compete with present day international tuna fishing industries. By accomplishing the above, they hoped to safely navigate the Minami tuna fishing grounds in the Southern Hemisphere, in the offshore waters of Australia in the high south latitudes. Minami tuna has recently become very popular as sushi-dane and sashimi on the domestic market because of its similarity to bluefin tuna. The major fishing grounds for Minami tuna are in the offshore waters of Australia from the 90 degrees east longitude

to 160 degrees west and in the high latitudes from 10 to 45 degrees south, where the weather is rather bad. The sail-in-all-weather type boats mentioned above are very effective in bad weather. As for Minami tuna, the ratio of landing of Minami tuna in Shizuoka Prefecture to the entire Japanese bluefin tuna catch is gradually increasing; in 1959 the ratio reached 77.8%; even now, after suffering a decrease in Minami tuna landings, the ratio is 79% because the bluefin tuna catch has also decreased. In Shizuoka most of the Minami tuna caught are landed in two fishing ports, i.e., Yaizu and Shimizu. Consequently, the Yaizu Fisheries Co-operative Association, which is traditionally strong in tuna fishing, owns many boats and Taien Refrigeration in Shimizu has many contract boats. Figure 6 shows the Minami tuna fishing grounds operated by the Yaizu FCA, most of which are offshore the west coast of Australia and offshore Cape Town. Fish stock of Minami tuna is not all that promising; Mr Narashina, Yaizu Branch of the Japan Pelagic Fisheries Laboratory reported that, around 1959 when Minami tuna fishing was starting to be promoted, it took 10-15 days (one operation per day) to obtain a full load, but now it takes 90-100 days. Also, it was impossible to land as many Minami tuna as around 1959. In any case, a quite large change occurred in the domestic tuna market after the pelagic tuna fisheries began exploiting the domestic market rather

Chart 9. Minami Tuna Landed in Shizuoka Prefecture

Year	Nationwide	Shizuoka P.	Minami tuna
	tuna catch	Minami tuna landings	Bluefin
	ton	ton	%
1953	5,070	—	
1954	3,878	1,193	30.76
1955	3,885	1,399	36.01
1956	9,139	5,104	55.85
1957	13,864	9,514	68.62
1958	12,807	8,189	69.94
1959	36,331	28,242	78.74
1960	53,518	37,830	70.69
1961	58,183	40,479	69.57
1962	32,590	24,473	75.09
1963	45,254	33,847	74.79
1964	37,361	27,672	74.07
1965	34,690	27,402	78.99
1966	30,840	23,592	76.50

(Record of the 8th Bonito-Tuna Resources Research Conference)
 (March 1969, Japan Marine Resources Preservation Conference,
 p 30)

Average Prices of the Major Varieties of Fish in the Landing
 Fish Markets from January to October 1969

Fish	Average price	Fish	Average price
	kg yen		kg yen
1 ミナミマグロ	351	マカジキ	319
2 メバチ	219	メカジキ	211
3 メジ(ダルマ)	135	クロカジキ	246
4 ビンナガ	173	シロカジキ	278
5 キハダ	190	カツオ	93

(Shimizu Fishing Port Promotion Committee Investigation)

Key:

- | | |
|----------------|-------------------|
| 1. Minami tuna | 6. Striped marlin |
| 2. Bigeye | 7. Swordfish |
| 3. | 8. Black marlin |
| 4. Albacore | 9. White marlin |
| 5. Yellowfin | 10. Bonito |

than the export market, with the development of rapid cooling machines of -45°C capacity. Frozen tuna is classed as processed goods and can be traded outside of fish markets. Thus, the system tends to shift from the traditional public auction in fish markets to direct purchase by full boat load. Like yellowfin tuna, frozen tuna and canning tuna for export used to be bought by major trading companies and canning manufacturers and was treated like any other fish on the domestic fish market. However, the exploitation of the pelagic fishing grounds, the construction of larger fishing boats, the installation of rapid cooling machines, and trading in the international fish markets encouraged changes in the tuna trading system. For example, an average frozen tuna landing per fishing boat from a pelagic ground is over 300 tons; thus, it is very inconvenient to trade after defreezing, considering the extra time and labor required. As for trading companies, it is much simpler for them to buy a whole boatload. And they became more confident with the shift to a cold chain system at the production center. For major food trading companies, there is the choice of whether to sell on the domestic market or to export, considering market conditions. With the improvement of the rapid cooling technique, not only Minami tuna but also yellowfin and bigeye can, like bluefin tuna, be sent onto the domestic market as sashimi or sushi-dane. Consequently, the domestic tuna market

expanded and, as domestic demands grow, purchase by the boat load is not limited to Japanese boats but is also applied to Korean, Taiwanese, and Okinawan boats. In the next stage, it is just a matter of time until so-called "port-of-call loading" or "on-board loading" is adopted; the tuna boats would prefer to operate in this way rather than spending long periods of time and incurring great expense shipping out from their home port for each trip. Nowadays, large-size cooling carriers are operated in the ports for port-of-call landing. These new trading systems were first used by the Taien group which is led by Taien Refrigeration, Inc. Taien Refrigeration started with 200,000 yen in May 1951 at Tsukiji-cho, Chimu. The company worked primarily as an agent for Toshoku, which was the leading tuna exporter. At that time, pelagic tuna fishing was in a boom period. The company kept expanding, building 1,000 tons of cool storage in 1959, 4,000 tons in 1962, initiating "port-of-call loading" operations in the Indian Ocean in 1963, building a large-size cooling carrier (the 18th Taien-Marun -- 1,300 tons) in 1964, building the 21st Taien-Marun (999 tons) in 1966, building a cooling carrier (the 28th Taien-Marun -- 999 tons) and a 400-ton class tuna fishing boat (the 25th Taien-Marun) in 1967, building the 31st Taien-Marun (2,860 tons) and the two 5,600 tons Mie Yokkaichi cool storage units with capacities of -40°C 20 tons per day in 1968, and building a cooling carrier (Taien-Marun --

7,000 tons) for "on-board landing" operations at Tamatabu Port. Taien Refrigeration, Inc. has separated its fishery department off into the independent Taien Fishery, Inc. The Taien group has five cooling carriers for a total of 13,216 tons. They contract with 90 fishing boats in Mie, Shizuoka, and Kochi Prefectures; although the export division is dependent on the Toshoku Co., there is a promising business on the domestic market. For example, their tuna landing from January to October 1969 reached 33,221 tons, far above Nippon Reizo's 9,681 tons and Kaigai's 9,015 tons. In the same period, total tuna landing traded on a boatload basis by the major companies was 60,069 tons; thus, Taien Refrigeration's share was 55%. Taien Refrigeration's tuna fishery is supported by the so called "Seven Samurai" of the Taien groups (four in Mie and two in Shizuoka). In the beginning, financial connections were a major factor, i.e., the fishing boat owners who were still dependent on pole and line fishing and lagging behind in the modernization of the tuna industry were aided by Taien Refrigeration when they were ready for modernization. There is said to be no such relationship nowadays because of the establishment of the Minor Fisheries Modernization Fund. In any case, Taien Refrigeration played an important role in the era of modernization of tuna fisheries. With the boatload purchasing system becoming popular, a problem arises in a fish market that has traditionally

close trading relationships with brokers (commission merchants), and breaking up those relationships is quite difficult. In particular, Yaizu Port encountered problems due to the influence of the movements of Taien Refrigeration at Shimizu Port. In the Yaizu market, they defrosted frozen tuna first and started the auctions after the brokers' inspections were over. In this traditional system, there is no room for the boatload purchasing system. Brokers, generally, do not have enough capital to operate by "boatload purchasing" and have difficulties adapting to modernization of the trading system. On the other hand, in Shimizu, there were no traditional brokers, hence no hindrances to the growth of the major fishery capital owners like Shimizu Shokuhin KK and Taien Refrigeration, Inc. To defrost frozen tuna to send to the markets is rather inefficient and unscientific now that the cold chain trading route has been established. At present, the ratio of trading frozen and defrosted is half and half at the Tsukiji market in Tokyo. It is important for the Japanese fishing industry to solve this problem.

4. The Modernization of the Tuna Fisheries and the Establishment of a Finance System

As mentioned above, the modernization of tuna fisheries in the post-war era could not have been achieved without an adjustment of the finance system of the governmental development fund. Right after the War, the governmental

reconstruction fund primarily encouraged the major fisheries and did little for the minor ones. However, the food crises of the era accelerated the reconstruction of the fisheries; brokers and shipbuilding furnished funds to minor fisheries, and provincial banks also advanced funds. A characteristic of the financing in these cases was that the producers and the financing establishments were equal or producers were sometimes in control, in contrast to the pre-war situation in which the producers were controlled by the finance companies. The financing establishments were pressured by the necessity of insuring a catch. In the meantime, local banks gradually withdrew funds from the fisheries. This tendency is clearly shown in a table showing debit balance, which indicates a peak of 3.44% in June 1958, and a decrease to 1.14% in March 1951. In other words, bank loans shifted from fisheries to other general industries as the fisheries recovered. Under the economic stabilization policy, that is, under the production priority system, banks practiced selective financing and had to establish a finance system for the minor fisheries and shore fisheries as funds from provincial banks became seriously problematic under the Dodge Line policy. At first, the establishment of fishery financing with promissory notes had been aimed at, but the system based on mutual aid failed because of poor, unsteady management in Minor fisheries themselves. Minor fisheries gradually came to depend on funds from fisheries cooperative

associations such as the Central Bank for Agriculture and Forestry. In late 1952, the Fisheries Credit Finance Association was founded by the Minor Fisheries Finance Assurance Law; on 27 December 1952, the Bank for Agriculture, Forestry, and Fisheries Law was passed. Thus, "funds are to be available for long periods and at low interest to any agriculture, forestry, or fishery establishment for development and maintenance of production, whenever the Central Bank for Agriculture and Forestry or any other financing agent cannot easily advance [such funds]..." (Article 1). This law had been revised 26 times by 2 May 1968; these revisions should be considered as strengthening Article 1 in accordance with economic changes in agriculture and fishing during those years. July 1963, the Minor Enterprises Basic Law took effect, under which modernization of management in minor industries has been promoted. With respect to fisheries, the Minor Fisheries Advancement Special Treatment Law was established, and the bonito-tuna fisheries were the designated fisheries. In the years around 1967, bonito-tuna fisheries came to an important turning point; they were shifting their major emphasis from the export market to the domestic market due to severe competition from the United States, Korea, Taiwan, and so forth on the international market. Chart 10 shows changes in the debit balance of fisheries from March 1960 to March 1964. In those 5 years, related financing

Chart 10. Changes in the Loan Balance Differentiated by Financing Agency with Respect to the Fishing Industry

Time	Mar 60(A)	Mar 61	Mar 62	Mar 63(B)	Mar 64(C)	C/A	C/B
						%	%
General funding agencies	1,073	1,242	1,414	1,685	1,923	179	114
Related funding agencies	379	511	763	1,011	1,192	315	118
Public funding agencies	238	250	266	294	360	151	124
Total	1,690	2,002	2,442	2,990	3,475	206	116

(Unit: 100,000,000 yen)

(Sekai Suisan Soran (A Look at World Fisheries) p 41)

Chart 11-1. Financing Moves in Finance Corporation Fishing Vessel Financing Differentiated by Major Types of Fisheries Industry

(Suisan Shuho, Special edition No 559, March 1969, p 90)

1 (単位100万円)

2区 分	3 第1期 昭28年~33年		4 第2期 34年~38年		5 第3期 39年~42年		6 果 計	
	融 資 額	比 率	融 資 額	比 率	融 資 額	比 率	融 資 額	比 率
9 かつお・まぐろ	6,925	41	13,469	51	12,457	35	32,851	41
10 以西底びき網	2,379	14	2,567	10	3,705	10	8,651	11
11 中型船底びき網 (沖合底びき)	1,253	7	3,672	14	3,434	9	8,359	11
12 ま き 網	1,082	10	3,210	12	3,813	11	8,705	11
13 さ け ・ ま す	1,092	6	2,065	7	5,836	16	8,993	11
14 遠洋底びき網	—	—	706	3	5,011	14	5,717	7
15 そ の 他	3,464	22	860	3	1,657	51	5,981	8
16 計	16,795	100	26,549	100	35,913	100	79,257	100

Key:

- | | |
|------------------------|--|
| 1. Unit: 1,000,000 yen | 10. Western bottom trawling |
| 2. Classification | 11. Medium class boat bottom trawling (offshore trawl) |
| 3. Period 1: 1953-1958 | 12. Surrounding nets |
| 4. Period 2: 1959-1963 | 13. Salmon-trout |
| 5. Period 3: 1964-1967 | 14. Pelagic bottom trawling |
| 6. Total | 15. Other |
| 7. Amount of financing | 16. Total |
| 8. Ratio | |
| 9. Bonito-tuna | |

Chart 11-2. Changes in Financing of the Bonito-Tuna Industry
(Suisan Shuho, Special edition No 559, March 1969, p 91)

1 (単位100万円)

2 区 分	3 遠洋かつを・まぐろ			4 近海かつお・まぐろ			5 計		
	貸付金額	隻数	トン数	貸付金額	隻数	トン数	貸付金額	隻数	トン数
Fiscal 1963	6 4,618	7 111	8 19,267	6 240	7 27	8 1,045	6 4,858	7 138	8 20,312
Fiscal 1964	1,605	38	8,168	248	25	1,037	1,853	62	9,205
Fiscal 1965	2,048	45	9,056	314	27	1,215	2,362	72	10,271
Fiscal 1966	2,844	44	11,209	575	43	1,945	3,419	87	13,154
Fiscal 1967	4,195	54	13,547	628	37	1,743	4,823	91	15,290
Total	15,311	292	61,247	2,007	159	6,985	17,318	451	68,232

Key:

- | | |
|------------------------------|-------------------|
| 1. Unit: 1,000,000 yen | 5. Total |
| 2. Classification | 6. Amount of loan |
| 3. Pelagic bonito-tuna | 7. No of ships |
| 4. Adjacent seas bonito-tuna | 8. Tonnage |

agencies show the maximum increase, 3.2 times, and general financing agencies show a gradual increase every year for a total of 1.8 times over the 5 years, and government financing increased 50%. But if we compare 1964 with 1963, government financing increased at the highest rate. In these 5 years, major fishery establishments increased 1.6 times from a value of 66,900,000,000 yen to 112,800,000,000 yen. Other fishery establishments increased their worth 2.3 times, from 102,100,000,000 yen to 234,800,000,000 yen. Seventy to 80 percent of financial funds other than those going to major fishery establishments went to minor fishery establishments Of these funds, about 50% went to the bonito-tuna industry, 17% to the salmon-trout industry, 8% to the offshore bottom-trawl industry, 11% to the surrounding net

industry, and 14% to others (Sekai Suisan Soran p 41); this indicates that the bonito-tuna fisheries had preferential funding. Funds from the Bank for Agriculture, Forestry, and Fisheries are the highest in the second 5-year period, and the bonito-tuna industry obtained more than half, 51%. In the third 5-year period, funds for the bonito-tuna industry decreased to 35%, but nonetheless kept the largest share, which indicates a positive protective policy on the part of the government toward modernization of the bonito-tuna industry. This has been strengthened by the Minor Fisheries Advancement Special Treatment Law and the Minor Fishery Management Reconstruction Fund, which is to be granted to bonito-tuna fisheries in cases satisfying one of the following conditions. The law mentioned bonito-tuna fisheries, but the funds granted went mainly to tuna fisheries. The section on the bonito-tuna industry is excerpted from "Guide to Funding" (October 1968, p 8).

The Bonito-Tuna Fishing Industry

- (1) Funds for the owner of less than 4 fishing boats to expand to 4 boats
- (2) Funds for the owner of less than 4 fishing boats expanding to 4 boats to build or operate the fourth boat
- (3) Funds for the owners of less than 4 fishing boats expanding to 4 to 6 boats by merging to build or operate the new boats ((1), (2), and (3) include cases in which the desired total is less than 4)
- (4) Funds for the owner of less than 5 fishing boats to install or newly build a boat larger than 20 tons as follows

Fishing Boats Prior to Construction or Remodeling

Fishing Boats after Construction or Remodeling

- | | |
|---|--|
| 1. Under 240 tons without auto-reel | 1. Over 240 tons with auto-reel |
| 2. Under 270 tons without air blast hanger style high efficiency freezing equipment or semi-air blast tube shelf high efficiency freezing equipment | 2. Over 270 tons with air blast hanger high efficiency freezing equipment |
| 3. Under 180 tons without air blast hanger style high efficiency freezing equipment or semi-air blast shelf type high efficiency freezing equipment | 3. Over 180 tons with semi-air blast shelf type high efficiency freezing equipment |

(High efficiency freezing equipment is that with a freezing capacity of -40°C)

- (5) Funds for installation of mechanized reels, remote control devices, air blast hanger-type high efficiency cooling equipment, semi-blast shelf-type high efficiency cooling equipment, or brine cooling equipment

For the above funds the Bank for Agriculture, Forestry, and Fisheries changes interest to 6.5% per year with a deferment period of 3 years and a repayment period of 15 years, and funds are granted up to 120,000,000 yen per fishing vessel. These funds are obviously a great help to the tuna industry which is trying to bring back pelagic tuna on a competitive basis with adjacent seas tuna used for sashimi or sushi, as one notes when one comes across modern large size tuna

fishing boats built with the funds at pelagic fishery base ports such as Yaizu, Shimizu, and Misaki. Major fishery establishments such as Taien Refrigeration played important roles in promoting the boatload purchase system, as mentioned before; however, minor fisheries no longer have to depend financially on those major fishery products companies due to the establishment of the system of financing from the Bank for Agriculture, Forestry, and Fisheries. This was clearly shown in a report of research done in Mie Prefecture. As described later, modernization of Mie Fisheries is lagging behind that of other prefectures; i.e., in Mie Prefecture most of the minor fishing boat owners still depend on pole and line fishing, and they have had to have financial help from the major fishery establishments in order to accomplish the drastic changes involved in the modernization of the bonito-tuna industry. In this instance, the Bank for Agriculture, Forestry, and Fisheries played a role in liberating the minor fishing companies from the major fishery establishments. Thus, the minor fishing companies have become able to participate in boatload purchasing on equal terms with the major fishery establishments. Incoming fishing boat owners hope to sell as much frozen tuna as possible as quickly as possible, and in this case, it is far more convenient to sell by the boatload rather than little by little to brokers. Tuna frozen below -45°C is as hard as stone and loading and unloading operations can readily be mechanized. It seems out of

date to defrost frozen tuna and inspect it prior to purchase. Recently, frozen tuna has been sold just washed off with water at Tsukiji Fish Market, and fish brokers also have improved cutting techniques, adjusting themselves to the situation.

5. Management Analysis of the Effects of Modernization Funds

In the preceding chapter, some interpretations of the modernization of Japanese tuna fisheries and the establishment of a finance system were described and in the present chapter an actual development process of a specialized tuna industry in Mie Prefecture will be described. In Mie Prefecture, bonito fisheries have been traditionally popular. There was confidence in bonito fisheries; however, they were lagging behind other prefectures in tuna fishing. The locations of the base fishing ports of the bonito-tuna industry in Mie Prefecture can be divided into two areas; one is the southern Shima Peninsula and the other is the Owashi area. In the southern Shima Peninsula area, bonito fishing was popular at Hagiri, Wagi, Hamajima, Tasonoura Shukuura and Rekiura and Sukuri, Mikura, and Furue. As bonito fishing boats were mechanized and became larger, the fishing grounds were also expanded; i.e., the Mie fishing boats sailed out around the Hachijo Islands, Nojimazaki, and the Sanriku coastal waters. They landed at Misaki, Shiogama,

Figure 7. Map of the Distribution Differentiated by Boat Owner and Community in Mie Prefecture

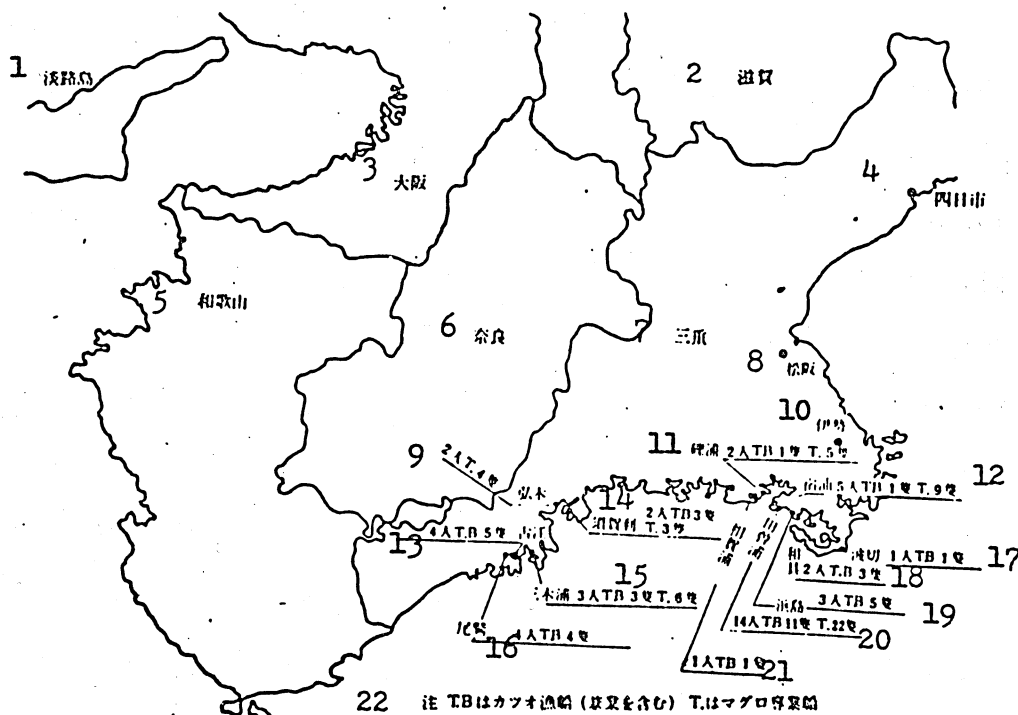

Key:

- | | |
|--|---|
| 1. Awajishima | 14. Sugari, 2 men TB 3 vessels, T 3 vessel |
| 2. Shiga | 15. Mikiura, 3 men TB 3, T 6 |
| 3. Osaka | 16. Owashi, 4 men TB 4 |
| 4. Yokkaichi | 17. Namagiri, 1 man TB 1 |
| 5. Wakayama | 18. Wagu, 2 men TB 3 |
| 6. Nara | 19. Hamajima, 3 men TB 5 |
| 7. Mie | 20. Tasoura, 14 men TB 11, T 22 |
| 8. Matsuzaka | 21. Sagaura, 1 man TB 1 |
| 9. Hiroki, 2men T 4 vessels | 22. TB is Bonito boats (including specialized industry), T is specialized tuna boat |
| 10. Ise | |
| 11. Rekiura | |
| 12. Yadoura, 5men TB 1 vessel, T 9 vessels | |
| 13. Furue, 4 men TB 5 vessels | |

Ishimaki, Kesenuma, and Miyako Ports, depending on the season; thus, they established close relations with the local fishery capital. In the special case of Mie Prefecture, there are about 30 "charter" fishing boats, in which the fishermen of Mie Prefecture are employed by boat owners from other prefectures. Employed fishermen have all the responsibility for operations, and they get 50-70% of the profit. This indicates the close relationship between bonito fishing techniques in Mie Prefecture and capital from other prefectures. Sometimes these fishermen become boat owners. Among the six fishery establishments in the present research, two are such charter managers. Tuna fishing in Mie Prefecture started around 1926, when bonito fishing boats went out to other coastal waters, by learning fishing techniques from Abusa. In those days about 100 small to large boats fished for tuna from October to April as a second fish after the close of the bonito season. However, the major pelagic fishing in Mie Prefecture was bonito fishing even after the War, and there was not a single specialized tuna fishing boat until 1952. In 1953, the first three tuna boats of the 350-ton class were built and sailed out into the albacore fishing grounds in the Indian Ocean. Once someone had built a specialized tuna fishing boat, it was much easier to follow suit, and the number of tuna boats increased to 10 in 1956. In the beginning they depended financially on

Chart 12. Trends in Combined and Specialized Fishing Vessels
in Mie Prefecture

Year	1 兼業船	2 専業船
1950	388	30
1955	83	7
1959	79	15
1960	69	18
1961	45	31
1962	28	34

(Katsuo Masuro Soran (A Look at Bonito-Tuna), p 377)

Key:

1. Combined vessels
2. Specialized vessels
3. Vessels

the 105th Bank, the Suruga Bank, and the Development Bank; but as these banks had stiff requirements due to economic drag, they shifted their financial dependence onto the Central Bank for Agriculture and Forestry, and the Bank for Agriculture, Forestry, and Fisheries. In the meantime, tuna fisheries suffered from the atomic bomb experiments on Bikini Atoll in March 1954. Thereafter, construction of larger size specialized tuna boats to go out further was encouraged; i.e., to the Southern Hemisphere waters and the Indian Ocean. In July 1953, the Fisheries Agency disclosed so-called "Special Regulations," which allowed for boat enlargement by size as of January 1952; i.e., the limit on the 20-70 ton

class was raised to 100 tons, the 70-90 ton class to 135 tons, the 95-100 ton class to 150 tons, and no limit was imposed on boats above 100 tons. This was in order to expand fishing grounds after the abolition of the Ma[llenkov?] Line. Agriculture and Fishery Reconstruction Fund was one of the major financial sources for this construction. The United States gave 20,000,000 dollars as a solatium for the Bikini incident, and involved personnel got shares of this. Then, the Japan Bonito-Tuna Fisheries Cooperative Association collected 150,000,000 yen from fishery establishments and 150,000,000 yen from the government and established the Japan Bonito-Tuna Fishery Credit Cooperative Fund Association. In Mie Prefecture, members of the Mie Bonito-Tuna Fisheries Co-operative Association could get financial assistance from the Central Bank for Agriculture and Forestry on the credit of the Japan Bonito-Tuna Fishery Credit Cooperative Fund Association. They could borrow 80% (actually about 70%) of the cost of installation or construction and 42,000 yen per ton for operation. Besides these funds, the Mie Bonito-Tuna Fishery Cooperative Association funded as much as twice the yearly balance of the Association Bank; a specialized tuna fishing boat could be built if one had about 20% of the total cost. The present research on fishery management shows the ratio of owned capital to the total capital to be 46% maximum, with 25% the average and a 14% minimum. Two are over 40%, four

are 40-30%, 10 are 30-20%, and five are 20-10%. Relationships between these local minor fisheries and the major fishery establishments such as Taien Refrigeration and Japan Refrigeration began around 1959-1960. These relationships sometimes work disadvantageously for producers in such areas as quality control and standardized weights and sometimes advantageously in such areas as financial support and boatload purchasing. It is rather difficult to distinguish over-all interests. As a matter of fact, five of the "Seven Samurai" of Taien Refrigeration are boat owners in Mie Prefecture. Payment in advance started in 1967, i.e., Mie Bonito-Tuna Fishing Cooperative Association funds 70% of the charges of the expected total landing of fish when the catch reached 50%. The financial situation of the specialized tuna fishing boats has been much improved by the Minor Fisheries Management Development Fund from the Bank for Agriculture, Forestry, and Fisheries established in 1967. The interest of the Central Bank for Agriculture, and Forestry for installation, construction, and advance payment is 8.39%; the interest of the Minor Fishery Management Development Fund is 6.5%, and the interest of the Coastal Fisheries Management Reconstruction Fund is 7.5%; with the former two funds there is a 0.3% commission for a Fishery Cooperative Association sublease. With this financial assistance, specialized tuna fishing boats rapidly increased in number in Mie Prefecture. Chart 13 shows the

Chart 13. Association Owned Boats

	年	1 100トン未満		2 200トン未満		3 300トン未満		4 400トン未満	
		5 隻数	6 トン 数	5 隻数	6 トン 数	5 隻数	6 トン 数	5 隻数	6 トン 数
7 か っ お 竿 釣 船	1964	3	239.53 (79.84)	14	2,559.77 (182.84)	8	1,885.18 (235.65)		
	1965	4	349.52 (87.38)	13	2,420.80 (186.22)	10	2,345.29 (234.53)	1	303.34
	1966	2	168.01 (84.01)	16	3,010.90 (188.18)	13	3,193.59 (245.66)	1	303.34
	1967	2	168.01 (84.01)	19	3,606.85 (189.83)	14	3,459.60 (247.11)	1	303.34
	1968	2	168.01 (84.01)	20	3,798.41 (189.92)	17	4,287.73 (252.22)	1	344.90
	1969	2	168.01 (84.01)	19	3,541.59 (186.40)	19	4,816.03 (253.48)	1	344.90
8 ま ぐ ろ 延 縄 船	1964	1	99.81	6	752.56 (125.43)	7	1,834.59 (262.08)	19	6,581.31 (346.38)
	1965	1	99.81	6	752.56 (125.43)	7	1,789.31 (255.62)	20	6,954.48 (347.72)
	1966	2	198.94 (99.47)	6	752.56 (125.43)	7	1,789.31 (255.62)	20	6,954.48 (347.72)
	1967	1	99.81	7	1,187.90 (169.70)	5	1,260.43 (255.09)	19	6,688.71 (352.04)
	1968			8	1,544.78 (193.10)	4	1,045.99 (261.50)	20	7,054.04 (352.70)
	1969			7	1,340.71 (191.53)	4	1,029.30 (257.33)	21	7,410.47 (352.88)
9 合 計	1964	4	339.34	20	3,312.33	15	3,719.77	19	6,581.31
	1965	5	449.33	19	3,173.36	17	4,134.60	21	7,257.82
	1966	4	366.95	22	3,763.46	20	4,982.90	21	7,257.82
	1967	3	267.82	26	4,794.75	19	4,720.03	20	6,992.05
	1968	2	168.01	28	5,343.19	21	5,333.72	21	7,398.94
	1969	2	168.01	26	4,832.30	23	5,845.33	22	7,755.37

Key:

1. Under 100 tons
2. Under 200 tons
3. Under 300 tons
4. Under 400 tons
5. No of vessels
6. Tonnage

7. Bonito pole and line boats
8. Tuna long line boats
9. Total

numbers of boats in the Mie Fishery Co-operative Association from 1964 to 1969. In 1969, the number of bonito fishing boats (including bonito-tuna fishing boats) was 41 and the number of tuna fishing boats 47. Five more specialized tuna fishing boats have been built since then, and the number has reached 52. Thus, bonito fishing yielded its traditional status as the leading fishing industry to tuna fishing.

Mie became a tuna fishing prefecture. Vessels from Mie appeared which specialized in tuna and their size began to increase in the period 1952-1955. These vessels operated in the Banda Sea, the Flores Sea, and the Java Sea, as well as in the Indian Ocean and off the west coast of Australia. The most important factor in the conditions of tuna fishing at that time was the extremely good catch rate for yellowfin. A voyage could be completed in 70-80 days of fishing, for it was possible to catch as much as ten tons in a day's operation using 300 to 350 cases of drift lines. After the Bikini test, however, and as the expansion of the vessels specializing in tuna advanced one stage, particularly in the 200-500 ton class of vessels, the tuna catch rate in the fisheries of the Indian Ocean and those of the west longitudes worsened since 1959-1960. In the worst case, one day's catch amounted to between 2 and 3 tons, approximately. Statistics on this period presented in the table show that the catch rate became 4.9 tons for one day's operation. Of course, at that time the production was primarily for frozen tuna exported to the United States. It was being shipped in refrigerated vessels at -20° C. Until 1952 the fishery was still

close to Japan, bonito and tuna were shipped there water-cooled, and brokers purchased the catch which was frozen at and exported from cold storage facilities near the fishery. Remembering all that, the fact that tuna was frozen at -20° C. was a forward step in itself.

1 推移 (年次別, 規模別, 隻数, 総トン数)

2 (各年度 4月1日現在)

3 500トン未満		4 1,000トン未満		5 1,000トン以上		6 合計	
7 隻数	ト 8 ャ ン 数	隻数	ト 8 ャ ン 数	隻数	ト 8 ャ ン 数	隻数	ト 8 ャ ン 数
		7		7		25	4,684.48 (187.38)
						28	5,418.95 (193.53)
						32	6,675.84 (208.62)
						36	7,537.80 (209.38)
						40	8,599.05 (214.98)
						41	8,870.53 (216.35)
2	848.05 (424.03)	2	1,583.70 (791.85)	1	1,452.95	38	13,152.97 (346.13)
2	848.05 (424.03)	2	1,583.70 (791.85)	1	1,452.39	39	13,480.86 (345.66)
2	848.05 (424.03)	2	1,583.70 (791.85)	1	1,452.95	40	13,579.99 (339.50)
3	1,250.50 (416.83)	2	1,583.70 (791.85)	1	1,452.95	38	13,524.00 (355.89)
6	2,507.46 (417.91)	3	2,854.13 (951.38)	1	1,452.95	42	16,459.35 (391.89)
11	4,621.25 (420.11)	3	2,854.13 (951.38)	1	1,452.95	47	18,708.81 (398.06)
2	848.05	2	1,583.70	1	1,452.95	63	17,837.45
2	848.05	2	1,583.70	1	1,452.95	67	18,899.81
2	848.05	2	1,583.70	1	1,452.95	72	20,255.83
3	1,250.50	2	1,583.70	1	1,452.95	74	21,061.80
6	2,507.46	3	2,854.13	1	1,452.95	82	25,058.40
11	4,621.25	3	2,854.13	1	1,452.95	88	27,579.34

9 () は平均トン数 かつを竿釣船には兼業船を含む

1. The transition (classified by year, by size, by number of vessels, by gross tonnage) 2. As of April 1 of each year 3. Less than 500 tons 4. Less than 1000 tons 5. More than 1000 tons 6. Total 7. Number of vessels 8. Tonnage 9. Figures in parentheses are average tonnages, including both pole fishing vessels and part-time vessels

Since around 1957, when tuna fishing grounds expanded into the South Pacific waters, cooling of -20°C capacity became inadequate, and all fishing boats started to install coolers of -30°C capacity. Around 1961-1962, the catch rate in the East Pacific offshore waters of Chile dropped; therefore, fishing boats from Mie Prefecture started to sail into the Atlantic Ocean. The first fishing boat sailing in the Atlantic Ocean was the fifteenth Kaio-Maru (330 tons), which had a contract with Japan Refrigeration. It used Recife Port, Brazil as a base. Around 1960-1962, when the Kaio-Maru first started to fish, they had a quite profitable catch of about 6-7 tons per operation day with 300-350 cases of drift lines. Other specialized tuna fishing boats, after they heard the good news, rushed into the Atlantic Ocean; the number of boats reached around 150 in 1962-1963. Then, in 1964, an average catch per operation day dropped to 2-3 tons with 400-450 cases of drift lines. Around 1964, Japan began to lose her large share of the international tuna market due to the activity of Korea and Taiwan and finally gave up first place in 1967. In the Atlantic Ocean, they could not land their catches directly in the United States, so they used relay ports such as Las Palmas (Canary Islands, Spain), Bristobal (America), Recife (Brazil, home consumption), Torinlatto [transliteration] (America), and Santiago, and so forth. Transport ships of Nihon Refrigeration and Toshoku

Figure 8. A Look at Overseas Bases

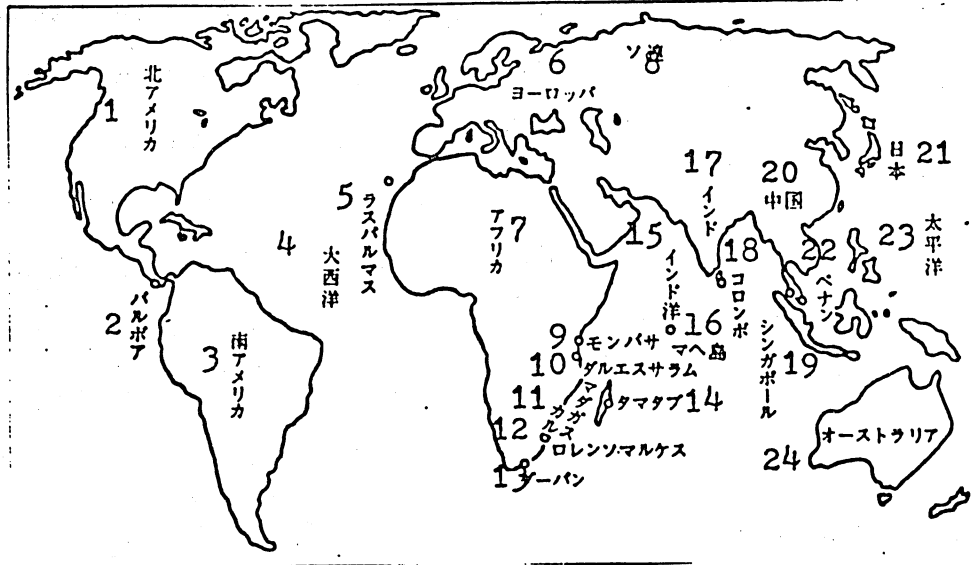

Key:

- | | |
|----------------------|-------------------|
| 1. North America | 14. Tamatabu |
| 2. Balboa | 15. Indian Ocean |
| 3. South America | 16. Mahe Island |
| 4. Atlantic Ocean | 17. India |
| 5. Las Palmas | 18. Colombo |
| 6. Europe | 19. Singapore |
| 7. Africa | 20. China |
| 8. USSR | 21. Japan |
| 9. Monbaza | 22. Penan |
| 10. Dar es Salaam | 23. Pacific Ocean |
| 11. Madagascar | 24. Australia |
| 12. Lourenco Marques | |
| 13. Durban | |

carried the tuna to the United States. Not a few operations developed deficits. Around 1964-1965, more than several fishing companies went bankrupt. Fortunately, the fishing grounds in the Indian Ocean then improved and domestic demands for Minami tuna increased. Japanese tuna fishery shifted direction from the international market to the domestic market. It was quite lucky for tuna fisheries, that at that time Japan was in a big economic boom period, the so-called Showa Genroku, and the market was able to consume all they caught. As changes took place in the marketing system as has already been discussed, not only Minami tuna, which is similar to bluefin tuna, but also yellowfin tuna and bigeye were found to be usable as sashimi and sushi-dane if they were frozen at around -45°C when caught. Taien Refrigeration constructed, very recently, a large storage plant in Yokkaichi, Mie, which can instantly freeze 20 tons per day to -40°C with a 5,600 tons capacity. This indicates its intention to exploit new markets in the Kansai area. Taien Refrigeration's tuna business reached 16,100,000,000 yen in 1967, 19,000,000,000 in 1968, and is said to aim at over 20,000,000,000 yen in 1969, which indicates an increasing domestic demand. Before 1965, they landed -30°C frozen tuna at Shimizu and A- class at Misaki, but since 1965 it does not matter where they land because they freeze tuna at -45°C . It is now only a matter of a contract with a boatload

purchasing partner. Buyers determine prices depending on the year of boats built, i.e., tuna caught by boats built before 1965 are 15-20 yen cheaper per kilogram than that caught by boats built after 1965. Therefore, some boats built before 1965 have installed -45° to -50°C high efficiency cooling equipment. The prices of tuna differ depending on the fishing grounds. They are around 200 yen per kilogram for Indian Ocean tuna, and 220-230 yen for west longitude tuna, with particularly good prices for Marlin. Recently the tuna fishing boats of Kochi and Shizuoka Prefectures mainly sail out into the southern Pacific Ocean to catch Minami tuna, but 60% of the Mie Prefecture boats sail out into the Indian Ocean to catch yellowfin, albacore, and bigeye tuna, 30% into the west longitude waters for Marlin, bigeye and yellowfin tuna, and 10% into the southern Pacific Ocean for Minami tuna. Up to October 1969, 18 boats had cooler or freezing capacity of -30°C , one boat of -35°C , 6 boats of -40°C , one boat of -42°C , 8 boats of -45°C , one boat of -47°C , 15 boats of -50°C , and 1 unknown (probably around -30°C because the boat was completed in November 1961) out of the 51 specialized tuna fishing boats in Mie Prefecture. These figures show a significant improvement in cooling machinery in recent years.

Numerical data indicating economic effects of funding modernizing installations are not readily provided, but at least we should consider problems dealing with rationalization and those dealing with fish price determination

separately. If we separate the idea of modernization of installations into 1) cooling equipment and 2) boat accommodations, we find that funds for cooling equipment are directly related to fish prices. On the other hand, funds for inside accommodations or equipment such as the auto-reel, line winder, and remote control systems are related to rationalization, subsequently, to labor power and wages. Rationalization [of labor] may result in increased wages per person.

As mentioned earlier, since the emphasis was shifted from international to domestic markets, tuna has commanded 15-20 yen more if rapidly frozen at -50°C and stored at -45°C rather than frozen at -30°C to -35°C . It became very popular in those days to increase cooling capacity, but it is rather difficult to find proper data showing direct economical effects due to renovations of this type. In our data, the only complete data for the balance sheets of four fishing seasons concern fishing boats on which old-type cooling equipment was installed. Modernized, large size boats with high efficiency cooling machines are not ready with complete data. If we assume tendencies from other information such as total yearly and monthly catch and average unit prices for tuna from 1953 to 1968, we would know that the prices could not be decided by only one factor but rather by an interaction of several factors. For this reason it is not possible to interpret direct economic effects of

Data 3. Study of Tuna Price Changes
 (Data from the Mie Bonito-Tuna Fisheries Co-operative
 Association)

1 年 度	2 数 斤	4 金 額	5 千 円	6 単 価
1953	3 878	97,327	111	
1954	1,990	171,456	86	
1955	2,583	169,114	65	
1955	7,418	664,426	90	
1957	9,724	741,928	76	
1958	12,432	1,015,058	82	
1959	17,809	1,578,197	88	
1960	20,961	1,823,256	87	
1961	26,147	2,384,933	91	
1962	25,369	2,848,889	112	
1963	25,516	3,112,956	122	
1964	23,266	2,868,283	123	
1965	22,845	2,801,736	123	
1966	23,951	3,908,493	163	
1967	19,393	3,314,860	171	
1968	26,192	4,945,398	188	

Key:

- | | |
|----------------|-----------------|
| 1. Fiscal year | 4. Price |
| 2. Amount | 5. Thousand yen |
| 3. Ton | 6. Unit price |

the installation of high efficiency cooling equipment from the chart showing the monthly changes of average tuna prices. In any case, the price in 1969 was 35.1 yen higher than that in 1968, and the price in 1966 was 31.9 yen higher than that in 1965, when the market changed from international to domestic. The latter price change corresponds to the market change. The former price change is considered indicative of

a price increase due to lower temperature freezing (-50°C) and storing (-45°C) as compared with -30° to -35°C and -25° to -30°C , respectively, with the old-type cooling equipment. Similar interpretations can be made from Data 3, which show changes in price from 1953 to 1963 and indicate higher prices after 1966. When the high efficiency cooler becomes common, the tuna price generally increases, but the difference in price between an individual price when tuna is landed and an average price gradually decreases. Consequently, the economic effects of installation on prices are greater in the early years and smaller later. But, after high efficiency cooling equipment becomes common, the specialized boats which cannot undertake its installation lose out in the price competition. Thus, every owner tried to install a high efficiency cooler; however, in Mie Prefecture a semi-air blast shelf-type rapid cooling machine was installed more commonly than the automatic air blast hanger type cooling machines. This may be the reason that people do not fully understand the achievements of rationalization with the latter. Data 1 also shows that there have been more plans to install high efficiency coolers than to install line winders and auto-reels. For the purpose of the rationalization of inside accommodations, most of the 21 fishing boats studied in Mie Prefecture have water machines and facsimiles. But only 10 had remote control auto-steerers, 8 remote control engines, and 6 both. These installations are not objects of

funding from the Bank for Agriculture, Forestry, and Fisheries. The only object for funding from the Bank in order to rationalize fishing boat accommodations is the auto-reel; it is rather strange that the line winder is not included even though both execute a similar function. Only 5 boats have installed line winders, and every one of them was built in 1967 and 1968 and is a large size boat over 402 tons. Manager M. mentioned once that it is doubtful whether it is advantageous to use the auto-reel rather than a line winder with respect to wear and tear on the main lines. Most of the specialized fishing boats in Yaizu install the auto-reel or line winder, but few boats in Mie Prefecture install this equipment, perhaps because they have enough labor power and agree with Mr. M. In Mie, there are 2-3 more fishermen per crew than in Yaizu. Two boats have 24.8, two boats have 25, two have 25.5, one has 26.3, one has 26.5, and three have 27.8 fishermen. Fishing boat ownership in Mie Prefecture is shown in Chart 14. There are four owners who have more than four specialized tuna fishing boats, four owners have three, eight owners have two, and five owners have just one boat. The Fisheries Agency has decided that an owner needs at least four specialized tuna fishing boats to have stable management and development. The Bank for Agriculture, Forestry, and Fisheries founded "funds for owner of less than four fishing boats to build up to four."

Chart 14. Fishing Boat Ownership

1	经营者 No.	2 TB 隻数	BT 隻数	塔 母	1	经营者 No.	2 TB 隻数	BT 隻数	塔 母
	1	2				23		3	
	2	1				24		2	1
	3	2				25	1	2	
	4	1				26	1		
	5	3				27	1		
	6	1				28	1		
	7	1	3	2		29	1		
	8		5			30		4	
	9	1	3			31	1		
	10		1			32		2	1
	11	1	2			33	3		
	12		4			34	1		
	13	1				35	1		
	14	1	2			36		2	
	15	1	1			37	1		
	16	1	1			38	1	2	
	17	2				39	1	2	
	18	1				40	2		
	19	1				41	1		
	20		3			42	1		
	21		1			43	1		
	22	1	2						

Key:

- 1. Manager No.
- 2. TB vessels

- 3. T vessels
- 4. Mothership

There is no particular reason why the Fisheries Agency fixed on four boats, but in any case the Mie Bonito-tuna Fishery Co-operative Association decided to follow their lead and four have already reached the initial aim. One of these four owners has three specialized tuna fishing boats and a carrying mothership. Four owners who have three boats each are also trying to reach the recommendation of the Fisheries Agency and

Data 4-A. Average Catch and Price for Four Outings
Profit Summary

		No. 7 K F 丸	No. 3 S S 丸	No. 7 S S 丸	No. 8 K. Q 丸	No. 28 K Q 丸	No. 1 T A 丸	No. 8 T A 丸	
3	水揚高 (A)	数量	294.1	255.3	280.3	338.5	322	336.3	735.8
		金額	67,718.0	45,722.8	54,203.5	66,236	71,481	57,009.5	132,979.8
4	漁業支出 (B) 計	54,679.7	35,996.5	45,680	44,954.6	56,268.5	47,652.1	107,289.0	
5	漁業利益 % A-B	13,038.3	9,726.3	8,523.5	21,281.4	15,212.5	9,357.4	25,690.8	
		19.3	21.3	15.7	32.1	21.3	16.4	19.3	

Key:

1. Maru
2. 1,000 yen
3. Landing (A) (tonnage (Price
4. Fishery expenditure (B) Total
5. Fishery Profit A-B

Data 4-B. Term end Credit and Loan Balances
Summary

4 項目	1 経営体 M 氏 ²			Y 氏 ²			N 氏 ²			1966
	1966	1967	1968	1966	1967	1968	1966	1967	1968	
5 期末預金残高 (A)	89,574	98,182	86,465	76,230	47,398	44,333	25,987	35,937	70,721	201,327
6 期末借入残高計 (B)	179,060	275,000	257,500	146,500	101,110	303,699	175,505	212,708	356,119	649,660
% (A/B)	50.0	35.7	33.6	52.0	46.9	14.6	14.8	16.9	19.9	31.0

Key:

1. Manager
2. Mr.
3. Fiscal year
4. Item
5. Term end credit balance (A)
6. Term end loan balance total (B)

(Taken from Data 1) (A)

No. 5 CHO丸	No. 11 CHO丸	No. 8 K O 丸	No. 17 K O 丸	No. 11 K O 丸	No. 2 S N 丸	Total	Average
399 2千円 69,843.3	298 2千円 65,248	305.8 2千円 55,761.8	310.3 2千円 68,528.3	450.3 2千円 76,314.3	300 2千円 57,434.3	4,625.7 2千円 888,480.6	355.8 2千円 68,344.7
52,039.9	64,839.6	49,739.1	56,687.6	57,890.2	51,859.4	725,576.2	55,813.6
17,803.4 25.5	408.4 0.6	6,062.7 10.9	11,840.7 17.3	18,424.0 24.1	5,574.9 9.7	162,944.3	12,534.2 18.3

(Taken from Data 1) (B)

1. Maru

Y A 氏 2		O 氏 2			N A 氏 2			Yadoura Pelagic Fishery Ka		
1967	1968	1966	1967	1968	1966	1967	1968	1966	1967	1968
219,981	182,123	100,933	117,810	129,834	336,062	366,712	378,144	40,849	49,465	49,427
637,200	633,900	303,601	470,934	480,848	649,800	837,711	1,039,922	81,500	142,650	100,000
34.5	28.7	33.3	25.0	27.0	51.7	43.8	36.4	50.1	34.7	49.4

2. Mr.

Data 5. Public Finance Agency, Tokai Branch Data:
Summary of Brail, Profit Rate (31 August 1969)

	1 水揚高(千円)	2 利益(千円)	3 利益率		1 水揚高	2 利 益	3 利益率
1	56,250	2,290	4.1	19	43,000	1,406	3.2
2	64,000	3,146	4.9	20	109,440	1,496	1.3
3	80,600	3,833	4.7	21	108,000	8,813	8.1
4	62,877	5,063	8.0	22	99,000	995	1.0
5	70,000	2,556	3.6	23	49,500	4,430	8.9
6	78,000	891	1.1	24	103,680	1,786	1.7
7	81,000	2,930	3.6	25	83,000	1,652	1.9
8	86,600	2,536	2.9	26	62,176	1,810	2.9
9	77,280	1,628	2.1	27	76,070	9,477	12.4
10	85,050	1,689	1.9	28	65,975	1,237	1.8
11	72,000	1,302	1.8	29	92,480	1,683	3.1
12	74,880	1,842	2.4	30	98,000	3,127	3.1
13	76,320	5,842	7.6	31	84,000	1,463	1.7
14	92,000	1,645	1.7	32	83,600	1,942	2.3
15	86,400	1,571	1.8	33	98,400	6,032	6.1
16	41,500	1,359	3.2	34	102,600	1,667	1.6
17	92,000	2,290	2.4	計	2,742,598	94,137	
18	106,920	2,708	2.5	平均	80,664.7	2,768.7	3.4

Key:

1. Brail (1,000 yen)
2. Profit (1,000 yen)
3. Profit rate

the main concern is their forecast about the future of tuna resources and price stabilization. In a capitalist economy, expansion of management is more or less indispensable even for minor fishing establishments. Therefore, fishing boat owners have always to pay attention to the modernization of their fishing boats to compete with others and have to be willing to get proper funding. Data 3 (B) shows a balance-account which indicates that the ratio of deposit to loan decreased in 1967 and 1968 as compared with 1966 and, consequently, that dependency on the Central Bank for Agriculture and Forestry and the Bank for Agriculture, Forestry, and Fisheries increased. Data 1 also shows that fishery establishments paid more interest to other city banks than to the above two banks. Average catch and profit per season in four fishing seasons were 68,344,700 yen (355.8 tons) and 12,534,200 yen (18.3%). The fishery interest of 18.3% seems fairly good business.

However, it may not be proper to judge over-all management of the specialized tuna fisheries in Mie Prefecture by these results since the objects of the present research were more or less better fishery establishments. In any case, from data on the bonito-tuna industry in the Tokai area, the average profit ratio at 31 August 1969 was 3.4%. This is far less than Mie's 18.3%, even if the data of the Tokai area included bonito fisheries in addition to the specialized tuna fisheries. The Bank for Agriculture, Forestry, and Fisheries also reported the

range of average interests are between 1.0 to 12.4%. There are no deficit cases reported perhaps because of difficulties of obtaining any further funding in case of deficit. In any way, it is fair to say that fishery management in the Mie Bonito-Tuna Fishery Cooperative Association is quite stable. This may be the result of strenuous efforts on the part of the fishery establishments to modernize and reconstruct the post-war tuna industry under proper guidance of the Association and timely assistance in funding from the banks.

Data 6-1. Fiscal 1968 Landing Report
(Mie Pref. Bonito-Tuna Fisheries Co-op. Assoc.)

	No. of trips	Amnt. of landing	Price of landing	No. of trips	Amnt. of landing	Price of landing
1	5	634	86,560	25	4	465
2	5	530	67,680	26	2	646
3	2	2,383	434,975	27	2	616
4	2	1,490	305,601	28	2	1,605
5	2	333	80,047	29	3	622
6	1	311	54,163	30	2	585
7	5	486	66,503	31	1	321
8	4	510	67,663	32	2	644
9	5	546	75,120	33	2	245
10	2	577	126,714	34	2	340
11	4	729	139,087	35	2	207
12	2	328	48,678	36	2	699
13	3	501	71,727	37	2	537
14	1	314	51,191	38	2	1,493
15	2	617	141,823	39	2	343
16	3	800	138,722	40	1	297
17	2	523	104,604	41	2	483
18	5	495	68,069	42	1	21
19	2	362	95,265	43	1	139
20	4	588	96,515	44	1	230
21	3	757	144,373	45	1	35
22	1	280	50,451			
23	1	304	57,000	Total	108	25,479
24	3	488	80,251	Avg.	2.4	566.2
						4,805,989
						106,799.8

Data 6-2. Fiscal 1969 Landing Report

	No. of trips	Amnt. of landing	Price of landing	No. of trips	Amnt. of landing	Price of landing
1	2	372	81,971	27	1	330
2	2	167	25,296	28	1	312
3	2	252	39,711	29	2	489
4	1	1,130	215,156	30	2	1,552
5	1	739	146,852	31	1	253
6	2	297	101,664	32	3	670
7	3	297	37,815	33	1	324
8	3	283	45,073	34	3	713
9	3	325	59,004	35	3	287
10	1	284	69,892	26	1	206
11	1	294	67,635	37	2	200
12	2	320	55,508	38	1	346
13	1	241	36,104	39	2	443
14	2	678	137,437	40	2	1,340
15	2	623	147,883	41	1	292
16	2	617	147,635	42	2	588
17	1	294	66,982	43	2	476
18	2	347	63,438	44	1	318
19	4	411	53,996	45	2	684
20	2	375	77,810	46	1	333
21	1	247	43,413	47	1	166
22	2	546	126,907	48	1	216
23	1	365	76,150			
24	2	576	135,216	Total	86	21,411
25	2	367	64,678	Avg.	1.8	446.1
26	3	426	62,038			4,564,503
						95,093.8

Summary

The Bonito-tuna fisheries are the most typical fisheries in which a capitalist production system has developed. An advancement in the bonito-tuna industry resulted in minor fishery establishments and a labor class. This formation is due to the interaction between merchant capital, bonito-tuna fishing techniques, and the development of fishery products as commodities. In the pre-war era, the development was more or less spontaneous but rather slow processes in fishery establishments themselves, mostly depending on being subsidized by the national or prefectural governments. In the post-war era, on the other hand, it was much encouraged by urgent demands for food, a newer public finance system, and loans from city banks. Rationalization and modernization have been drastically carried out since around 1949 and 1950, when pole and line bonito fisheries and drift net tuna fisheries began to separate. Establishment of a finance system by the Central Bank of Agriculture and Forestry greatly assisted these developments, together with the Fishery Credit Finance Association and the Bank for Agriculture, Forestry, and Fisheries, both founded in 1952. In the meantime, pelagic tuna fishing was also supported by the major fisheries food industries in its modernization.

Capital tends to keep going anarchically under the law of value, and the expansion of production undergoes by in-

stallation investment with free competition among establishments. In the present research on the "Study of Economic Effects of Modernized Installation Investment on Far Seas Tuna Fishery," the author considered the subject capitalist competition in the tuna industry. Modernization in tuna fishing results in a reduction of working hours, and consequently, with generalization and equipoise of operation hours, the individual profit is also going to be balanced. Thus, economic effects of modernized installation investment under the finance system already described become relative ones which may not be the same for more than several years. Consequently, this problem should not be considered only as the pursuit of profits; the problem has to be expanded to cover the development of fishery production and fishery resources, and we have to consider what has to be done for development of tuna fishing in the long run.

Major References

- Kawasaki, Ken, "Ecology and Resources of the Bonito I, II," Suisan Kenkyu Goshu (Fisheries Research Collection) 8-12, Tokyo, Ishizaki Shoten, 1965.
- Nakamura, Koji, "World Tuna Resources I, II," Suisan Kenkyu Goshu 10-2, Tokyo, Ishizaki Shoten, 1965.
- Masuda, S., A Look at Bonito-Tuna, Tokyo, Suisan-sha, 1963.
- _____, Suisan Sekai (Marine World) Vol. 17, No 8, Tokyo, Agriculture and Forestry Economic Research Laboratory, 1968.
- _____, Suisan Shuho (Marine Weekly Report), No 559, No 580, Tokyo, Suisan-sha, 1969.
- Fisheries Agency Korean Fisheries Research Group, "Korean Fisheries II," Kaigai Suisan Goshu (Overseas Fisheries Collection), Tokyo, Ishizaki Shoten, 1967.
- Nakamura, Koji, "Taiwan's Tuna Industry," Kaigai Suisan Goshu, Tokyo, Ishizaki Shoten, 1966.
- Fisheries Agency, Ed., A Look at the World's Fisheries, Agriculture and Forestry Economic Research Laboratory, 1965.
- Bank for Agriculture, Forestry, and Fisheries, Guide to Funds, 1968.

Table 2 Summary of Tuna Fishing Grounds
(Combined bonito and tuna summary drawn from pages 123-152)

Area	Region	Primary Characteristics of the Fishing Grounds
Fishing grounds off the coast of Japan	Hokkaido and Sanriku region	Northern limit of the distribution of the tuna and marlin genus. The fishing season is for four months between April and October, and the center of the fishing grounds moves north with the months from offshore Kinkazan to offshore Samezu and to offshore Erimo. The cold Kurile Current extends to the surface of the Sanriku fishing grounds, and because bluefin tuna migrate relatively near the surface, they become the object of stretched net fishing.
	Izu Archipelago and eastern region	Although the fishing season for albacore is between November and March, it is most prosperous in January. It makes up 80% of the catch of all fish. Bigeyed tuna (December and January) is second, and bluefin tuna and yellowfin tuna (May to October) are negligible. Fishing gear is stretched line and pole and line.
	Kinan region	The base of operations for the operational area of the stretched line fishing boats catching small types of tuna is primarily Katsuura in Wakayama-ken, and also Yaizu, Kagoshima, and Kuroto. Fishing season is October to April, and although the best fishing season for albacore is February and March, it is possible to operate year round. During excellent periods of the north equatorial drift current and the Japan Current, there are yellowfin tuna, turbot, and bluefin tuna. During excellent periods of the reverse Japan Current, there are bigeyed tuna and albacore.
	Satsunan region	There are bluefin tuna from end of December to April. The best fishing season is March. Average weight during the fishing season is 180 kg.
	East China Sea region	This region is divided into two by the Japan Current, which flows north on the west side of the Okinawa Archipelago. The western side of this fishing area is called the East China Sea fishing grounds, and the eastern side is

<p>Fishing grounds off the coast of Japan (cont.)</p>	<p>East China Sea region (cont.)</p>	<p>called the Okinawa fishing grounds. Between July and September, there are striped marlin and white marlin in the coastal waters of Sumizushima. In October and December, the fishing grounds move south from the previous area. The fishing situation is active, with striped marlin, white marlin, and sailfish. Between January and March, the fishing grounds move south, and there are white marlin and sailfish around Jotsurishima. At the Ckinawa fishing grounds, there are albacore, bigeyed tuna, and yellowfin tuna. Between April and June, the Ckinawa fishing grounds become the main fishing area; there are bluefin tuna, yellowfin tuña, and striped marlin.</p>
	<p>Japan Sea region</p>	<p>Between early May and the middle of July, fish approach the coast on the Tsushima warm current moving northward and are caught by fixed shore nets from Wakasa-wan through Notohanto to Toyama-wan. Although they are rare around Korea and the coastal provinces (of China), fish are sometimes caught off the coast of Sakhalin past the western coast of Hokkaido in years when the warm current is strong. Only bluefin tuna migrate there.</p>
<p>Northern Pacific Ocean fishing grounds</p>	<p>This indicates the fishing grounds which are at the central part of the Pacific Ocean in the area between 150° east and 150° west longitude, north of 25° north latitude. They are formed by the semitropical convergent line and its northern part, which are the tide borders of the north equitorial drift current and the north Pacific Ocean current. This is closest to the base of the stretched line tuna</p>	<p>i) Fisheries with albacore and big-eyed tuna as their primary objective: Until about August to November, bigeyed tuna is the main objective, but from the latter half of December to March, the number of albacore increases and bigeyed tuna decreases in areas closer to the coast. Besides this, bluefin tuna, swordfish, and striped marlin are caught depending on the period and area. Stretched line fishing is dullest from April to July.</p> <p>ii) Fisheries with bluefin tuna as their primary objective.</p>

<p>Northern Pacific Ocean fishing grounds (cont.)</p>	<p>fishing boats. Also, the characteristics of these fishing grounds vary little in the 180 degrees of longitude east and west, and from the north Pacific Ocean current to the semitropical convergent line.</p>	<p>iii) Fisheries with broadbill swordfish as their primary objective: Among broadbill swordfish, migrating groups going south are observed in August off the east coast of Hokkaido, between 42° and 46° north latitude, east of 160° east longitude. Fishing grounds are formed off the Sanriku coast from September to November. From November to December, the fishing grounds move south rapidly, and fishing grounds are formed east of the Izu islands during January. The southward migration stops after March.</p>	
<p>Northern Pacific Ocean middle latitudes fishing grounds</p>	<p>These are the fishing grounds in the long, narrow area east to west 18° to 28° north latitude in the semitropical convergent area. It is considered to have low marine production capability. These are the fishing grounds for small, 50 ton, boat operations.</p>	<p>Okinotorishima waters Ogasawara waters Cocos waters</p>	<p>Yellowfin tuna are caught all year round; in winter albacore, in spring striped marlin, and in summer black marlin are caught. From October to January the tuna genus and from May to July the marlin genus and yellowfin tuna are the primary objectives of the catch. The catch of bigeyed tuna increases from December to February and that of striped marlin increase from April to June. Black marlin are also numerous. In autumn and winter the tuna genus and in summer yellow fin tuna are the main catch. As a whole, bluefin tuna and yellow fin tuna tend to decrease toward the east, and bigeyed tuna tend to increase.</p>
<p>South China Sea fishing grounds</p>	<p>The primary catch of the South China Sea fishing grounds is yellowfin tuna, followed by bigeyed tuna. In September, the fishing grounds form in the southern part, near the Shinnan Islands. In December, yellowfin tuna spread to almost all parts of the South China</p>		

<p>South China Sea fishing grounds (cont.)</p>		<p>Sea and are especially favorable in the western part of the area. Bigeyed tuna are at the northern side of Shinnan Islands. From March to April, the catch of both yellowfin and bigeyed tuna decreases around Hainan island. The catch of yellowfin tuna between Shinnan Islands and Indochina and that of bigeyed tuna south of 14° north latitude improve, but they decrease from May to June, and there are almost no operations from July to August.</p>
<p>Pacific Ocean equatorial fishing grounds (fishing grounds north of the equator and south of the semitropical convergent line)</p>	<p>Region from the equator to 6° north latitude</p>	<p>Yellowfin tuna: 130°E to 150°E: April, May, and November are the most prosperous periods. January and August are the poorest. 150°E to 170°E: Almost the same seasonal changes as in the western waters, but the variations are not so remarkable. 170°E to 150°W: The catch is the greatest in June and shows a completely different variation from that of the western part of the fishing grounds. 150°W to 130°W: The catch rate is low from June to December. 130°W to 120°W: No seasonal changes are observed.</p> <p>The catch of bigeyed tuna is poor all year round, but when the catch is poor north of 6° north latitude, it becomes better in these waters.</p> <p>Black marlin: The catch rate is poor as a whole. 150°W to 130°W: The catch rate is high from June to December. 130°W to 120°W: There are no seasonal changes in the catch rate. 130°E to 130°W: The catch rate is high April to September (in the western area) and around July to November (in the central and eastern area).</p>
	<p>Region from 6° to 12° north latitude</p>	<p>Bigeyed tuna: 130°E to 170°E: The catch rate is high from October to January, and it is the lowest from May to August. This tendency is especially strong in the waters west of 150° east longitude.</p>

Pacific
Ocean
equatorial
fishing
grounds
(cont.)

Region
from 6° to
12° north
latitude
(cont.)

170°E to 150°W: The catch rate is high from January to June, and it is the lowest in August. It is quite different from that of the more western waters.

170°W to 150°W: The catch rate is highest from April to July.

150°W to: June to December is the highest.

130°W to 120°W: No seasonal changes.

Yellowfin tuna:

130°E to 150°E: May, June, November, and December are high.

150°E to 170°E: High from May to August, and the formation of the main fishing grounds comes later than the west.

170°E to 170°W: The catch rate is lower than in the western waters, but it is high in August.

170°W to 150°W: The catch rate is high from August to November.

150°W to: Highest during June and July.

Black marlin:

130°E to 150°E: Slightly higher from May to September.

150°E to 170°E: There are no seasonal changes in the catch rate, but it is higher than that of the western waters the year round.

170°E to 170°W: The catch rate is high between June and September, but moving eastward, the period comes later and later.

170°W to: In waters east of 170° west longitude, the catch is slightly lower than in the western waters.

140°W to 130°W: High from October to November.

Region
east of
150° west
longitude.
This is
recently
developed
fishing

These are good fishing grounds where yellowfin tuna and bigeyed tuna are caught in mixtures. Looking at the surface temperature distribution in these water, a cold water zone extends toward the center of the ocean from the American continents along the equator. It retreats eastward around May and extends westward from August to November. This ocean condition

<p>Pacific Ocean equitorial fishing grounds (ccnt.)</p>	<p>ground, and it has been since 1957 that many fishing boats started to fish here.</p>	<p>largely controls the fishing situation in these water.</p> <p>In regards to the fishing situation, during April and May the fishing grounds formed north of the equator and those formed south of the equator are nearly adjacent, but as the months advance, they separate to the north and south with the equator as their border. From December to March, the process occurring from April to November is reversed, and the conditions return to those of April and May. Also, from around May and June to around November and December, bigeyed tuna are numerous and the catch of yellowfin tuna decreases. The catch situation of yellowfin tuna fluctuates violently. That is to say, when the effects of the cold water are strong between May and November, the catch situation of bigeyed tuna is good, and the catch situation of yellowfin tuna is good when this effect is weaker. The catch rate of black marlin is lower in every month than that of bigeyed and yellowfin tuna, and the seasonal variation is not clear at present.</p>
---	---	--

<p>South Pacific Ocean fishing grounds</p>	<p>This is as important a fishing area as the Indian Ocean. Yellowfin tuna, albacore, and southern tuna are distributed in that order from the lower to higher latitudes. They are arranged regularly, with partial overlapping. Yellowfin tuna are distributed north of 15° south latitude, albacore between 10° and 30° south latitude, and southern tuna south of 30° south latitude. In the area near Australia, yellowfin tuna are distributed as far as 30° south latitude</p>	<p><u>History of Fishing Ground Development</u></p> <p>From June to September of 1952, a group of tuna mother ships of the Pacific Ocean fishing industry went fishing into the waters adjacent to the Solomon Islands and had good catches, mainly of yellowfin tuna. At an early period, the waters north of about 12°-15° south latitude were developed from east to west, extending from around 150° east longitude in the Coral Sea to the west to the western longitudes to the east. In the latter half of 1953, good fishing grounds for yellowfin tuna were formed between 20° and 25° south latitude near Australia, and the fishing boats converged there. Next, large schools of albacore were found in the middle latitude waters of the South Pacific, and from 1954 to 1955, the</p>
--	--	---

<p>South Pacific Ocean fishing grounds (cont.)</p>	<p>along the continent. White marlin, black marlin, striped marlin, and bigeyed tuna are distributed irregularly north of 20° south latitude in these waters.</p>	<p>development of the wide fishing grounds extending from the seas adjacent to Australia to the western longitudes was done mainly by groups of mother ship type boats and by groups of boats with the Samoan Islands as their base. From 1955 to 1956, the fishing grounds were slowly extended eastward on the whole, between 10° and 20° south latitude. Good fishing grounds for black marlin were developed east of 160° west longitude. Also between 1954 and 1955, fishing grounds with white marlin as the main catch were found between 10° and 20° south latitude in the Coral Sea near Australia. The waters south of 30° south latitude were developed from 1957, and they became excellent fishing grounds for southern tuna. Also around 1957, fishing grounds were developed north of 20° south latitude, slightly to the east, and a good fishing ground for bigeyed and yellowfin tuna was developed at around 130° west longitude.</p>
<p>Indian Ocean waters and neighboring fishing grounds</p>	<p>Ocean center waters west of 100° east longitude</p>	<p><u>History of Fishing Ground Development</u> A survey was conducted from 1930 to 1933 by the Shirataka-maru, the Haruna-maru, and the Shonan-maru in the Banda-Flores Sea in the eastern part of the Indian Ocean. This included the Bay of Bengal, the west coast of Sumatra, the coast of Java, Lesser Sunda Island, and the coast of Timor. In 1952, operations were conducted for the first time after the war in the Banda-Flores Sea and off the coast of Timor. After that, the fishing grounds were extended to the west, and in 1955, they passed 50° east longitude and reached the waters adjacent to Africa. The fishing grounds developed throughout the Indian Ocean.</p>

Indian
Ocean
waters and
neighboring
fishing
grounds
(cont.)

Ocean center waters
west of 100° east
longitude
(continued)

The types of fish caught are yellowfin tuna, albacore, bigeyed tuna, striped marlin, white marlin, broadbill swordfish, sailfish, and furai marlin, which are similar to those in the Pacific Ocean, but the most important type is yellowfin tuna, followed by albacore and southern tuna. Southern tuna was previously called Indian tuna. The quality of its meat is close to that of bluefin tuna, and it brings a high price due to the domestic demand. As with goshu tuna, its catch is increasing. Looking at the distribution of the main types of catch in the area with 10°-8° south latitude as its southern boundary, we can see that yellowfin tuna are numerous to the north, and albacore are numerous to the south. Also, southern tuna are numerous in the waters along the eastern islands which are surrounded by Australia, Java, and Lesser Sunda Island. The Indian Ocean fishing grounds are located from about 20° north latitude to about 30° south latitude, which are at considerably lower latitudes and different than the other fishing grounds, but their catch situation and the formation of the fishing grounds are determined by the marine conditions of the Indian Ocean.

Fishing Grounds from Jan. to March

Yellowfin tuna fishing grounds are formed at the most southern part around December and January, and they move somewhat northward during February and March. In all, the fishing grounds in these waters are (a) yellowfin tuna fishing grounds along the equatorial counter current, (b) yellowfin tuna and albacore mixed catch fishing grounds centered on the boundary of the south equatorial

Indian
Ocean
waters and
neighboring
fishing
grounds
(cont.)

Ocean center waters
west of 100° east
longitude
(continued)

current and the equatorial counter current, and (c) yellowfin tuna fishing grounds centered on the equator at the west coast of Sumatra.

Fishing Grounds from April to June

Yellowfin tuna fishing grounds move slightly to the north as compared to the previous months and are located north of 5° south latitude, but the production is even higher than in the previous months. Also, during this period only, yellowfin tuna fishing grounds are formed in the northern waters from offshore Ceylon to near Andaman and Nicobar Islands. Also at these fishing grounds, bigeyed tuna, uro marlin, and striped marlin are caught in mixtures. This is the period when albacore become the most numerous in the south equatorial current area, but in the mixed catch fishing grounds (b) of the previous period, production decreases as a whole because the yellowfin tuna have moved north, and the operations are not very active.

Fishing Grounds from July to Sept.

The yellowfin tuna fishing grounds are from 3° north latitude to 5° south latitude, but the catch rate is lower than in the previous period. Mixed catch fishing grounds for yellowfin and bigeyed tuna are formed in the western half of the Indian Ocean centered on 5° north latitude, and later in August, the mixed catch of marlin increases.

Fishing Grounds from Oct. to Dec.

This is the part of the year when the production is the lowest. Yellowfin tuna move south from the previous period, and as in the period from January to March, the distribution den-

	<p>Ocean center waters west of 100° east longitude (continued)</p>	<p>sity increases in the waters north of the equator. The catch rate increases somewhat in December.</p>
<p>Indian Ocean waters and neighboring fishing grounds (cont.)</p>	<p>Waters east of 100° east longitude</p>	<p><u>Fishing Grounds from Jan. to March</u> A current rip is formed from south to north at around 110°-120° east longitude, and the south equatorial current reaches the west side of this current rip. Because of this, albacore, which are numerous in the area of the south equatorial current, are commonly distributed in the western part of these waters but they are not objects of the operations. Yellowfin tuna are numerous from the north side to the east side of the current rip, and in particular, good fishing grounds are formed from the Lesser Sunda Islands to the Timor waters (November to January) and at the northwest coast of Australia (January to February). At the northwest coast of Australia, large yellowfin tuna are the objective from January to February, but north of 17° south latitude, southern tuna are caught in mixtures. Also, yellowfin tuna decrease on the western side and albacore increase. The fishing period is slightly earlier in the Banda-Flores Sea than off the coast of Timor, and the fishing situation is worse in January. In the latter half of this period, in the waters between 110° and 120° east longitude, the catch of southern tuna increases, as in the previous September to December period.</p> <p><u>Fishing Grounds from April to June</u> The current rip between 110° and 120° east longitude disappears, and the south equatorial</p>

Indian
Ocean
waters and
neighboring
fishing
grounds
(cont.)

Waters east of 100°
east longitude
(continued)

current flows to the eastern part. Therefore, the distribution of albacore extends to the east, and only a few yellowfin tuna are caught near Java and the southern coast of the Lesser Sunda Islands. Because southern tuna also move south along the west coast of Australia during this period, the catch decreases markedly.

Fishing Grounds from July to Sept.

The sea conditions during this period are similar to those of the previous period, and the distribution of the important types of fish is also similar. However, the catch of yellowfin tuna gradually increases in the Banda-Flores Sea from about August. Especially during this period, thick schools of big-eyed tuna appear very close to shore from the Sunda Channel to Java and near the shores of Java between August and September. They extend westward along a line at 8°-10° south latitude and also northward along the west coast of Sumatra. The southern tuna fishing grounds form from about August, and dense schools are formed in September in the waters between 10° and 15° south latitude and between 110° and 120° east longitude. The types of fish in the mixed catch are of the marlin genus, and striped marlin is especially important, but yellowfin tuna and albacore are few.

Fishing Grounds from Oct. to Dec.

The sea conditions are similar to those in the period between January and March. From November to December, yellowfin tuna fishing grounds appear from the south coast of the Lesser Sunda Islands to the coast of Timor. The yellowfin tuna fishing

<p>Indian Ocean waters and neighboring fishing grounds (cont.)</p>	<p>Waters east of 100° east longitude (continued)</p>	<p>grounds formed subsequent to these are south of 3° south latitude in the Banda-Flores Sea. The catch rate of both yellowfin and bigeyed tuna are the highest in these waters during this period. However, the bigeyed tuna fishing grounds formed near the south coast of Java during the previous period become gradually worse. The best catching period for southern tuna continues from September, and the location of the fishing grounds is almost the same as those of the previous months. Besides this, striped marlin fishing grounds are formed at the northwest coast of Australia between 18° and 20° south latitude and 110° and 120° east longitude. Also, the mixed catch rate of bigeyed tuna increases.</p>
<p>Tuna fishing grounds in Atlantic Ocean</p>		<p><u>History of Fishing Ground Development</u> When the Boso Maru (408 tons, Chiba-ken) performed experimental tuna fishing in the Caribbean Sea from November, 1955 to June, 1956, it was the first time a Japanese fishing boat had ventured into the Atlantic Ocean. Next, fishing ground surveys were conducted by the Sagami Maru (700 tons, Kanagawa-ken) for one year from October, 1956 and by the Toko Maru (1,112 tons, Fisheries Agency) from December, 1956 to June, 1957. Yanashita Fisheries Corporation in cooperation with Japan Refrigeration Corporation had the 13th Kaiko Maru fish in this area, and it landed at the port of Recife for the first time in July, 1956. As a result, the superi-</p>

Tuna
fishing
grounds in
Atlantic
Ocean
(cont.)

Tuna Fishing Grounds and Currents of
the Atlantic Ocean

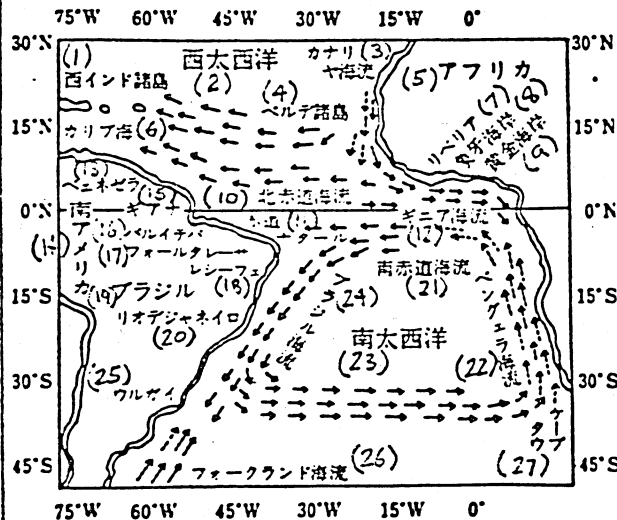

(Bonito and tuna summary, page 151,
Figure 59)

Key:

1. West Indies
2. West Atlantic Ocean
3. Canary Current
4. Verde Islands
5. Africa
6. Caribbean Sea
7. Liberia
8. Ivory Coast
9. Gold Coast
10. North equatorial drift current
11. Equator
12. Guinea Current
13. Venezuela
14. South America
15. Guiana
16. Baruiteba
17. Fortaleza
18. Recife
19. Brazil
20. Rio de Janeiro

ority of the Atlantic Ocean
fishing grounds was con-
firmed. The number of boats
sailing out to fish in-
creased to 26 in 1957 and to
as many as 169 in 1965, but
the number decreased con-
siderably to 49 in 1967.
Gekkan Gyogyo Kendo summary
(from fishing conditions in
1960 and 1961)

January: In 1960 and 1961, the
main fishing grounds were
two, one centered on the
equator and extending to 5°
south latitude off the coast
of the Gold Coast and the
other at 20° west longitude
off the coast of Natal and
Recife in the western part
of the Atlantic Ocean. How-
ever, the fishing grounds
off of the Gold Coast dis-
appeared in 1962, and yellow
fin tuna was the main catch
in the waters between the
equator west of 10° west
longitude and about 5° south
latitude.

February: Continuing from the
previous month, yellowfin
tuna fishing grounds formed
off of the Gold Coast, but
the fishing grounds gradual-
ly extended to the west, and
there were signs of them
moving southward. In Febru-
ary, 1962, main fishing
grounds were formed at the
center of the Atlantic Ocean,
that is between 0° and 15°
west longitude and between
the equator and 15° south
latitude, and they gradually
extended east and west.

March: The fishing grounds off
of the Gold Coast extended
north and southward, and op-
erations were conducted from
Liberia to about 10° south

Key (cont.):

21. South equatorial current
22. Benguela Current
23. South Atlantic Ocean
24. Brazil Current
25. Uruguay
26. Falkland Current
27. Cape Town

Tuna
fishing
grounds in
Atlantic
Ocean
(cont.)

latitude along the coast.

April: Almost the same as the previous month, but a considerable amount of bluefin tuna was caught off of Recife in 1960.

May: The fishing grounds move north gradually, and the center seems to move from off of the Gold Coast to off of Liberia. Also, the fishing grounds stretch out and form a long, narrow area between 5° north and 5° south latitude. The catch is mainly yellowfin tuna, which makes up 60 to 80 percent, and bigeyed tuna, albacore, and striped marlin are caught in mixtures.

June: The fishing grounds move mainly north of the equator and form at the center of the ocean, from the equator to 15° north latitude.

July: The July fishing grounds of 1960 were quite different from those of 1961. In 1960, the fishing grounds formed north of the equator, off of Venezuela and Dakar, but in 1961, operations were also conducted to the south, off of the Ivory Coast and Recife.

August: The fishing grounds are divided into those in the northern and those in the southern hemisphere. Yellowfin tuna are the objective north of the equator between 5° and 15° north latitude. South of the equator, bigeyed tuna fishing grounds are formed in the waters between 5° and 15° south latitude and between 5° and 15° east longitude from the middle of July.

September: Almost the same as in the previous month.

October: In 1960, almost all the segments of the fishing grounds converged at the northwest coast of the South American

Tuna
fishing
grounds in
Atlantic
Ocean
(cont.)

continent west of 30° west longitude, but from around the end of the month, the fishing grounds showed a tendency to move eastward in the waters at about 10° south latitude. In 1961, fishing grounds formed at first from near 15° north latitude and 60° west longitude across the equator to near 15° south latitude and 15° east longitude, as if crossing the Atlantic Ocean diagonally. However, in due course, the northwest part of the fishing grounds disappeared, and the important part of the fishing grounds was in the central part of the waters at 15° west longitude. It was located at the southeastern part and was considerably different, the composition of the fish being from 40 to 80 percent albacore.

November: The fishing grounds moved south again, and the main fishing grounds moved to waters south of the equator. In 1960, there were very good catches off of the Gold Coast. In 1961, the fishing grounds were wider than in the previous year and reached 30° west longitude. From the Gold Coast to Angola with 10° south latitude as the boundary, yellowfin tuna are numerous north of this boundary making up 88 percent of all the fish, and bigeyed tuna make up 90 percent south of this boundary. Also, at the central waters between 5° and 15° south latitude, the fish composition was remarkably different, being 40 to 80 percent albacore.

December: Compared to the previous month, the catching conditions are poorer, and the area of the fishing grounds is smaller. They have a tendency to split into two parts, off of

Tuna fishing grounds in Atlantic Ocean (cont.)		the Gold Coast and off of Recife. The fishing grounds off of Recife, which were south of the equator, had more active operations, and their best sea- son was for albacore.
---	--	--

